Nextel®

iDEN®

Digital Multi-Service Data-Capable Phone

i80s Phone User's Guide



NTN9884-A

Table of Contents

| | |
|---|-----------|
| Introduction | 1 |
| Welcome to Nextel® | 1 |
| Customer Care | 2 |
| Ordering Information | 3 |
| Driving Safety Tips | 3 |
| Getting Started..... | 5 |
| <i>i80s</i> Phone Features | 6 |
| <i>i80s</i> Phone Menu Tree | 7 |
| <i>i80s</i> Phone Icon Glossary..... | 8 |
| Battery | 9 |
| Turning Your <i>i80s</i> Phone On/Off | 11 |
| Enabling Security | 12 |
| Receiving Over-The-Air Programming..... | 12 |
| SIM Card | 13 |
| Keypad Lock | 20 |
| Status of Your <i>i80s</i> Phone..... | 23 |
| My Information | 23 |
| Using T9® Text Input | 24 |
| Display Essentials | 31 |
| Display Screen..... | 31 |
| Status Icons..... | 32 |
| Text Display Area | 34 |
| Call Information Icons..... | 34 |
| Menu Icon..... | 34 |
| Display Options..... | 34 |
| Navigating Menus and Lists..... | 35 |
| Main Menu Options..... | 36 |
| Phonebook..... | 39 |
| Phonebook Entries and Speed Dial Numbers..... | 40 |

| | |
|-------------------------------------|-----------|
| Phonebook Icons | 40 |
| Voice Names | 41 |
| Accessing Your Phonebook | 41 |
| About Phonebook Entries..... | 42 |
| Sorting Phonebook Entries..... | 43 |
| Pause Digit Entry..... | 51 |
| Plus Dialing | 52 |
| Address Book | 52 |
| Digital Cellular..... | 53 |
| Making Phone Calls | 54 |
| Emergency Calling | 59 |
| Special Dialing Codes | 59 |
| Receiving a Phone Call | 60 |
| Ending a Phone Call | 60 |
| Recent Calls..... | 61 |
| Call Timers..... | 64 |
| Hands-Free Speakerphone..... | 65 |
| Mute..... | 66 |
| Call Waiting | 66 |
| Call Hold | 68 |
| Three-Way Calling | 69 |
| Call Forwarding..... | 70 |
| Caller ID | 74 |
| Alternate Line Service..... | 75 |
| Call Restrictions | 77 |
| Nextel 411 | 77 |
| Nextel Voice Mail..... | 79 |
| Setting Up Your Voice Mail Box..... | 79 |
| Receiving Voice Mail Messages | 80 |
| Using Voice Mail | 81 |
| Advanced Voice Mail Features | 86 |
| Nextel Voice Mail Tree..... | 94 |

| | |
|----------------------------------|------------|
| Messages | 95 |
| Message Center | 95 |
| Nextel Voice Mail | 96 |
| Text and Numeric Messaging..... | 96 |
| Nextel Two-Way Messaging..... | 99 |
| | |
| Direct Connect | 101 |
| Nextel Direct Connect® | 101 |
| Private Call..... | 102 |
| Call Alerts..... | 104 |
| Group Call..... | 108 |
| | |
| Datebook..... | 113 |
| Datebook Icons..... | 114 |
| Viewing Your Datebook | 114 |
| About Datebook Events..... | 116 |
| Adding New Events..... | 117 |
| Editing Events | 121 |
| Deleting Events | 122 |
| Datebook Event Reminders..... | 122 |
| Customizing Datebook Set Up..... | 123 |
| | |
| Memo | 125 |
| Adding a New Memo | 125 |
| Viewing a Memo | 125 |
| Editing a Memo | 126 |
| Deleting a Memo | 126 |
| | |
| Voice Notes | 127 |
| About Voice Notes | 127 |
| Accessing Voice Notes..... | 128 |
| Recording a Voice Note | 128 |
| Playing a Voice Note..... | 129 |
| Adding to a Voice Note..... | 129 |

| | |
|--|------------|
| Labeling a Voice Note..... | 129 |
| Deleting Voice Notes | 130 |
| Locking/Unlocking a Voice Note..... | 131 |
| Voice Notes Memory | 131 |
| Nextel Wireless Web..... | 133 |
| Wireless Web Navigation Keys | 133 |
| Starting the Microbrowser..... | 134 |
| Using Your Phone as a Modem..... | 135 |
| Java Apps | 137 |
| Accessing Java Apps | 137 |
| Installing Java Apps | 138 |
| Running Java Apps..... | 138 |
| Downloading Custom Applications | 139 |
| Deinstalling Java Apps | 139 |
| Java Apps Memory..... | 140 |
| Customizing the i80s Phone..... | 141 |
| Settings | 141 |
| Styles | 156 |
| Shortcuts | 161 |
| Accessories..... | 165 |
| Batteries..... | 165 |
| Travel Chargers | 166 |
| Universal Serial Bus (USB) | 168 |
| Other Important Information | 169 |
| Nextel Customer Care | 169 |
| Understanding Status Messages | 170 |
| Nextel Terms and Conditions of Service | 172 |
| Safety and General Information | 178 |
| RF Operational Characteristics | 178 |
| Accessory Safety Information..... | 186 |

| | |
|---|------------|
| Limited Warranty Motorola Communication Products..... | 189 |
| Patent and Trademark Information..... | 197 |
| Index | 199 |

IMPORTANT!

Read “Nextel Terms and Conditions of Service” on page 172 and “Safety and General Information” on page 178 before using your *i80s* phone.

Introduction

Welcome to Nextel®

Thank you for choosing Nextel as your wireless communications provider. Your *i80s* phone enables you to enjoy clear connections through Nextel's All-Digital National Network. In addition, with Nextel WorldwideSM Service, you can use your *i80s* phone to roam internationally in select cities using other iDEN® networks.

Nextel gives you more ways than anyone to communicate with everyone.SM

Your *i80s* phone offers many innovative features:

- **Voice Activated Dialing** – Your *i80s* phone offers state-of-the-art Voice Activated Dialing.
- **Speakerphone** — You can enjoy hands-free communication at the touch of a button. And Speakerphone is especially great for conference calls.
- **Phonebook** – Your consolidated Phonebook holds up to 250 entries and allows you to store multiple contact numbers for each person, offering you various ways to communicate with your business and personal contacts.
- **SIM Card** – Your phone's SIM card holds all entries stored in your Phonebook. In addition, you have a PIN (Personal Identification Number) to keep your information safe and secure.
- **Datebook** – Schedule and keep track of appointments using your phone's Datebook feature.
- **Messages** – The Message Center allows you to manage and access your Voice Mail, Text Messages and Two-Way Messages all from the same inbox.
- **Nextel Direct Connect®** – With Nextel Direct Connect, you can use your phone as a digital two-way radio to communicate directly with business and personal contacts at a fraction of the cost of cellular calls.
- **Nextel Wireless Web** – Using the Net feature with the built-in microbrowser, you can access Nextel's wireless Internet. It offers a suite of Nextel wireless data products and Internet applications to quickly access the information you need to get business done.
- **J2ME™** – With the Java Apps feature, you can choose from the many Java programs developed for Nextel. Download Java applications directly from the Internet either over the air or using a cable. You can select which Java™ applications will best help you get your business done.

- **Customization** – Use the Settings, Styles and Shortcuts features to customize your i80s phone to meet your individual needs. Personalize your main menu order, designate unique ring styles, create a set of behaviors for your phone to use in certain situations such as meetings or in the car, and more.

For more information on these and other features of the i80s phone, review this User's Guide.

Enjoy using your i80s phone!

Customer Care

For domestic customer care issues, including billing issues, general service needs, or to order additional services, contact Nextel Customer Care.

Visit **nextel.com** for a variety of Customer Care services:

- **Browse** for information on phones, coverage, rates and other Nextel services. View and download user's guides, try out our interactive virtual products and service demos, find answers to frequently asked questions, order accessories, locate service and repair centers, upgrade phone software, send a message and more.
- For self-service on your Nextel account, click on **My Account** to view your account, pay your bill, add phones to your account, reset your Voice Mail password, and more.
- For online assistance, click on **Contact Us** to send us an email request. Our representatives are committed to assisting you. Every effort will be made to address your questions or concerns within 24 hours. Contact us to add Wireless Web and other services, change rate plans, inquire on your bill, and more.

Or, call us at 1-800-639-6111 or dial 611 from your Nextel phone.

To complement the i80s phone and Nextel Worldwide Service, Nextel has also launched International Roaming Customer Care support. When traveling outside of the U.S. and Canada, call +1 (201) 531-5202 for your Customer Care Service needs. This Customer Care number will be toll-free from your Nextel handset both domestically and internationally.

For more information about Nextel or to view this guide on our Web site, visit us on nextel.com.

International and domestic coverage, rates and other information are also available on nextel.com.

Ordering Information

Nextel Business Networks® allows you to communicate with individuals outside as well as inside your company. These Networks link Nextel customers in similar industries or geographies. So, if you need to reach a client, vendor, or contractor instantly, work smarter by joining the Nextel Business Networks. Call 1-888-NEXTEL2 (1-888-639-8352).

Various accessories are available for use with your *i80s* phone, including a Leather Case, Vehicle Battery Charger, extra Batteries, a variety of Hands-Free accessories, and more. To order accessories or an accessories catalog, go to nextel.com or call Nextel NextdaySM Accessories at 1-800-914-3240. You can also contact your Nextel Authorized Sales Representative or stop by any Nextel Store. For information on retail store locations, go to nextel.com.

Contact Nextel Customer Care to order any of the services discussed in this guide, including Nextel Wireless Web, Nextel Direct Connect, Additional Phone Services, Voice Mail, Nextel Mobile Messaging and much more!

For information on Direct ProtectSM insurance protection for your *i80s* phone, call 1-888-352-9182 or contact your Nextel Authorized Representative.

Visit us at nextel.com to learn more about Nextel products and services!

Driving Safety Tips

NOTE: For safety and legal reasons (in many countries), do not use your phone while driving.

Check and follow the local laws regarding the use of mobile phones while driving.

Safety — Your most important call. The Wireless Industry reminds you to use your phone safely when driving.

1. **Get to know your wireless phone and its features such as speed dial and redial.** Carefully read your instruction manual and learn to take advantage of valuable features most phones offer, including automatic redial and memory. Also, work to memorize the phone keypad so you can use the speed dial function without taking your attention off the road.
2. **When available, use a hands free device.** A number of hands free wireless phone accessories are readily available today. Whether you choose an installed mounted device for your wireless phone or a speaker phone accessory, take advantage of these devices if available to you.
3. **Position your wireless phone within easy reach.** Make sure you place your wireless phone within easy reach and where you can grab it without removing your eyes from the road. If you get an incoming call at an inconvenient time, if possible, let your voice mail answer it for you.

4. **Suspend conversations during hazardous driving conditions or situations.** Let the person you are speaking with know you are driving; if necessary, suspend the call in heavy traffic or hazardous weather conditions. Rain, sleet, snow and ice can be hazardous, but so is heavy traffic. As a driver, your first responsibility is to pay attention to the road.
5. **Do not take notes or look up phone numbers while driving.** If you are reading an address book or business card or writing a “to do” list while driving a car, then you are not watching where you are going. It's common sense. Don't get caught in a dangerous situation because you are reading or writing and not paying attention to the road or nearby vehicles.
6. **Dial sensibly and assess the traffic. If possible, place calls when you are not moving or before pulling into traffic.** Try to plan your calls before you begin your trip or attempt to coincide your calls with times you may be stopped at a stop sign, red light or otherwise stationary. But if you need to dial while driving, follow this simple tip — dial only a few numbers, check the road and your mirrors, then continue.
7. **Do not engage in stressful or emotional conversations that may be distracting.** Stressful or emotional conversations and driving do not mix — they are distracting and even dangerous when you are behind the wheel of a car. Make people you are talking with aware you are driving and if necessary, suspend conversations which have the potential to divert your attention from the road.
8. **Use your wireless phone to call for help.** Your wireless phone is one of the greatest tools you can own to protect yourself and your family in dangerous situations — with your phone at your side, help is only three numbers away. Dial 9-1-1 or other local emergency number in the case of fire, traffic accident, road hazard or medical emergencies. Remember, it is a free call on your wireless phone!
9. **Use your wireless phone to help others in emergencies.** Your wireless phone provides you a perfect opportunity to be a “Good Samaritan” in your community. If you see an auto accident, crime in progress or other serious emergency where lives are in danger, call 9-1-1 or other local emergency number, as you would want others to do for you.
10. **Call roadside assistance or a special wireless non-emergency assistance number when necessary.** Certain situations you encounter while driving may require attention but are not urgent enough to merit a call for emergency services. But you still can use your wireless phone to lend a hand. If you see a broken-down vehicle posing no serious hazard, a broken traffic signal, a minor traffic accident where no one appears to be injured or a vehicle you know to be stolen, call roadside assistance or other special non-emergency wireless numbers.



a safety reminder from
NEXTEL

Getting Started



This section will help you get started using your phone. It contains details about some of the features and functions described in the *Getting Started Guide*.

This section includes:



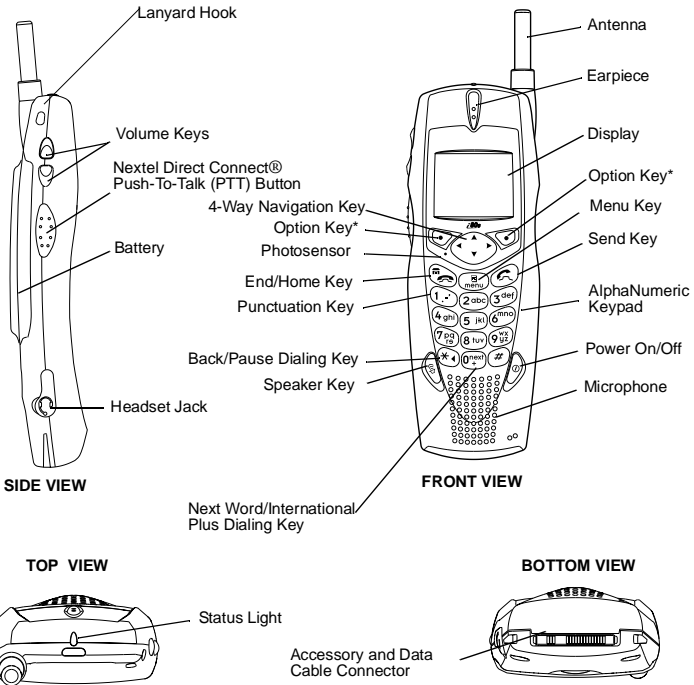

| | |
|--|---------|
| <i>i</i> 80s Phone Features | Page 6 |
| <i>i</i> 80s Phone Menu Tree | Page 7 |
| <i>i</i> 80s Phone Icon Glossary | Page 8 |
| Battery | Page 9 |
| Turning Your <i>i</i> 80s Phone On/Off | Page 11 |
| Enabling Security | Page 12 |
| Receiving Over-the-Air Programming | Page 12 |
| SIM Card | Page 13 |
| Keypad Lock | Page 20 |
| Status of Your <i>i</i> 80s Phone | Page 23 |
| My Information | Page 23 |
| Using T9 [®] Text Input | Page 24 |

i80s Phone Features



* Throughout this User's Guide, the option keys  and  will be represented by .

i80s Phone Menu Tree

You can access the main menu options by pressing  or  from the idle screen. Use  to navigate through the menus and submenus. Press  under the display option to perform the desired phone function.

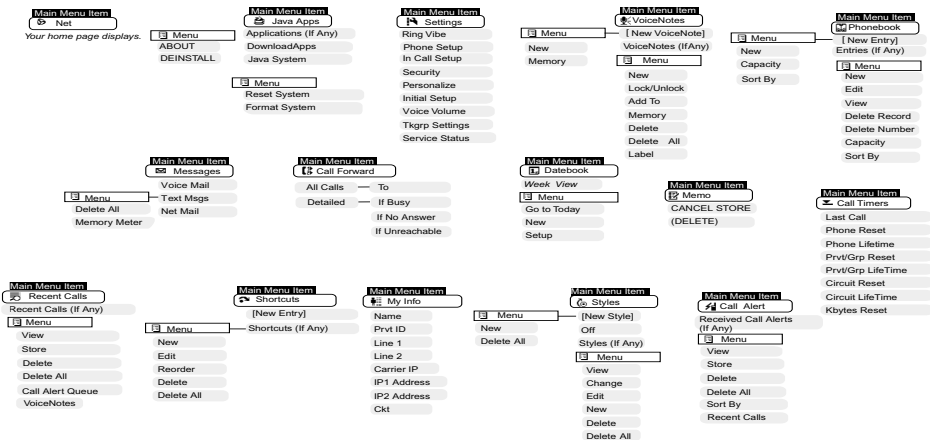

i80s Phone Icon Glossary

You may see these icons while using your i80s phone:

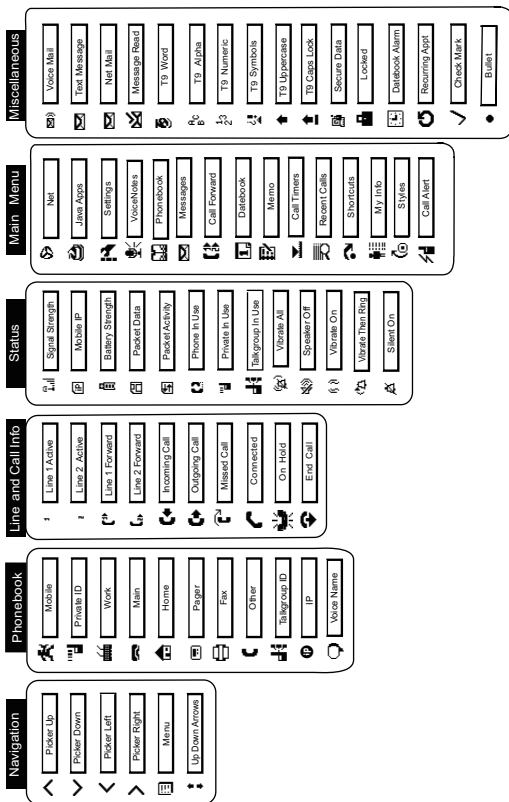

The icon of the main menu feature in use displays in the top left of the status icon rows. For a list of the main menu options, see “Main Menu Options” on page 36.

Battery

Your *i80s* phone comes with a Lithium Ion battery and charger. After attaching the battery, you must charge it before you use it for the first time. See “Batteries” on page 165 for the appropriate charging times for your phone’s battery. After the initial charging, the battery can be charged more quickly.

Remove the battery from the protective plastic safety tray provided in the original packaging. When the battery is not attached to the phone, store it in the original tray.

NOTE: The battery and cover are one piece.

Attaching the Battery

Insert the top of the battery into the battery area. Press down on the bottom of the battery to secure it. Push forward until you hear a click.

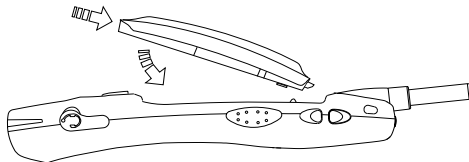

Detaching the Battery

- 1 Ensure the phone is powered off before attempting to detach the battery.
- 2 Press the battery release button and slide the battery away from the antenna.
- 3 Remove the battery by pushing the battery toward the antenna and lifting it out of the phone.

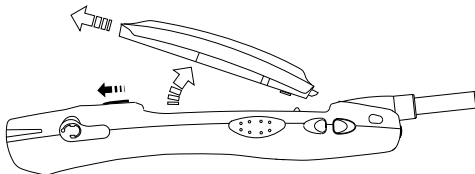

Charging the Battery

NOTE: The battery can be charged with the phone either turned on or off. For best results, charge it with the phone turned off.

- 1 With your phone's keypad facing up, plug the charger's accessory connector into the left side of the accessory connector on the bottom of the phone.



- 2 Plug the charger into an electrical outlet.

NOTE: Your phone's screen backlight will remain lit while the battery is charging.

Battery Charging Status

The battery strength indicator icon found on your phone's display screen shows the charge amount remaining in the battery.

When Using Phone

| | | | | |
|------------------|-------------|------------|------------|---------------|
| Icon Display | | | | |
| Battery Strength | Low Battery | 11% to 40% | 41% to 70% | Fully Charged |

NOTE: A short, chirp-like sound indicates a low battery. The icon flashes to indicate that you have approximately five minutes of talk time remaining.

When Charging Battery

| | | | | |
|------------------|-------------|------------|------------|---------------|
| Icon Display | | | | |
| Battery Strength | Low Battery | 31% to 60% | 61% to 90% | Fully Charged |

Turning Your i80s Phone On/Off

NOTE: To register for the first time on the Nextel National Network, you must turn on your i80s phone in your local calling area.

To power the phone on:

1 For optimal signal strength, extend the antenna.

2 Press and hold  near the bottom of the phone until the status light glows red, a tone briefly sounds, and **Powering On** displays.

3 If you have enabled your SIM PIN security feature (see “Enabling/Disabling the PIN Security Feature” on page 13), the **Enter SIM PIN Code** screen displays. Enter your SIM PIN (see “Entering the PIN” on page 15).

Press  under OK.

4 As your phone connects to the Nextel National Network, you will see **Welcome To Nextel** and a connecting message. When the idle screen appears on the display as shown here, you are ready to use your i80s phone!



If your display reads **No Service** or doesn't change to the idle screen when you turn on your phone, and you know you are in a Nextel coverage area, contact Nextel Customer Care. For details on Nextel coverage areas, go to nextel.com.





To power the phone off:

1 Press and hold  near the bottom of the phone until a tone briefly sounds and **Powering Off** displays.

2 Push down the antenna.

Enabling Security



The first time you power on your phone (or within 20 days of first activation of your phone), you must enable security.



| | |
|---|--|
| 1 | Turn your phone on (see “Turning Your i80s Phone On/Off” on page 11). |
| 2 | From the idle screen, press  . |
| 3 | Press  to scroll to Net . |
| 4 | Press  under SELECT . A series of screens displays. |
| 5 | You are prompted to enable security. Press  under Yes . If you subscribe to a Nextel Online SM Service Plan, your home page displays. |
| 6 | Press  to return to the idle screen. |

Receiving Over-The-Air Programming

If you have been set up to receive over-the-air programming OARSS, you will receive your Private ID and Talkgroup lists for Direct Connect use, your Personal Telephone Number and the Nextel Customer Care number via a Net Mail message.

In order to receive your programming, you must enable security (see “Enabling Security” on page 12). Within 24 hours of enabling security, you will receive a Net Mail message containing your lists. To accept your phone programming:

| | |
|---|---|
| 1 | You will receive a Net Mail alert with the message New Browser Message - Receive Programming Info . |
| 2 | Press  under GOTO . |
| 3 | You are prompted to accept changes to your phone's lists. Press  under OK . |
| 4 | A confirmation screen displays. Press  under OK . |

- | | |
|---|---|
| 5 | You are prompted again to accept changes to your phone's lists. Press  under OK. |
| 6 | A confirmation screen displays. Press  under OK. |
| 7 | Press  to return to the idle screen. |

SIM Card

Your phone comes with a built-in level of security protection through the use of the SIM (Subscriber Identity Module) card. The SIM card stores all your Phonebook information and your Nextel account identification information. Since this information is stored on the SIM card, not in your phone itself, you can remove the information by removing the SIM card.

The SIM card is located in the SIM Card Holder on the back of the phone, underneath the battery. You can verify the SIM card is in place by removing the battery and viewing the SIM card through the SIM card cover.

See “Removing/Inserting the SIM Card” on page 18 for information on locating the SIM card. If there is no SIM card in your phone, notify your Nextel Authorized Representative.

NOTE: Except for making emergency calls, your phone will not function without the SIM card.

SIM Card Personal Identification Number (PIN)

To prevent unauthorized use of your account, you can protect your SIM card by enabling the SIM PIN security feature. With the SIM PIN enabled, you must enter your PIN each time the phone is powered on. You can change or disable your PIN if desired.

NOTE: It is recommended that you enable the SIM PIN security feature to prevent fraudulent use of the SIM card.



Enabling/Disabling the PIN Security Feature

When the PIN security feature is enabled, you are prompted to enter your PIN each time you turn on your phone. Until a valid PIN is entered, you can use the phone only to make emergency calls.

After the PIN is accepted, the phone registers on the network and the idle screen displays.



When the PIN security feature is disabled, the phone can be used without entering a PIN.

| | |
|---|---|
|  Caution | <p>It is recommended that you enable the PIN security feature to protect personal data on your SIM card. This prevents anyone from using your phone and accessing your personal data.</p> |
|---|---|

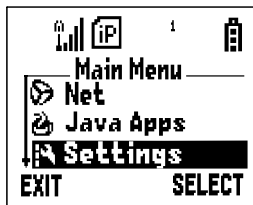

- 1 From the idle screen, press  and then press  to scroll to **Settings**.





- 2 Press  under SELECT. The **Settings** screen displays.

- 3 Press  to scroll to **Security**. Press  under SELECT to access the **Security** screen.



- 4 At the **Security** screen, press  to scroll to **SIM PIN**. Press  under SELECT to access the **SIM PIN** screen.

- 5 Press  to scroll to **On** or **Off**. **On** enables the SIM PIN security feature; **Off** disables the SIM PIN security feature. Press  under SELECT.

- 6 At the **Verify SIM PIN Code** screen, enter the current SIM PIN and press  under OK.

NOTE: Your default SIM card PIN is 0000.

Once you have enabled the SIM PIN security feature, it is recommended that you change your PIN to a number known only to you (see “Changing the PIN” on page 16).

Entering the PIN



Caution

Incorrectly entering your PIN three times causes the SIM card to be blocked. To unblock your SIM card, you must contact Nextel Customer Care. For more information, see “Unblocking the PIN” on page 17.

- 1 From the **Enter SIM PIN Code** screen, enter your four- to eight-digit PIN. An asterisk appears for each character entered. The default SIM PIN is 0000.

NOTE: Other than emergency dialing, you will be unable to use any of the phone functions, including receiving phone calls, until you enter the PIN.

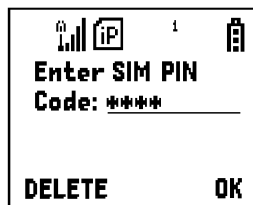



- 2 Press  under OK.

If you enter an incorrect PIN, the message **SIM PIN incorrect: Try again** appears on your phone's screen. After three consecutive incorrect attempts, the SIM card is blocked. Once blocked, the phone will not allow you to enter your PIN again, even after powering the phone off and back on. If this happens, see "Unlocking the PIN" on page 17.



Changing the PIN

NOTE: In order to change the PIN, the SIM PIN security feature must be set to On. See "Enabling/Disabling the PIN Security Feature" on page 13.

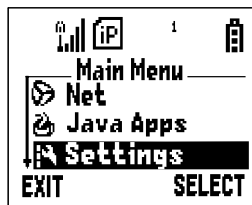
- 1 From the idle screen, press  and then press  to scroll to **Settings**.



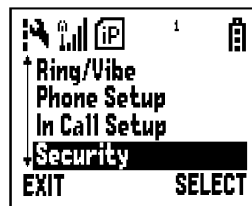

- 2 Press  under SELECT. The **Settings** screen displays.

- 3 Press  to scroll to **Security**. Press  under SELECT to access the **Security** screen.



- 4 At the **Security** screen, press  to scroll to **New Passwords**. Press  under SELECT to access the **New Passwords** screen.

- 5 At the **New Passwords** screen, press  to scroll to **SIM PIN** and press  under SELECT.

- 6** At the **Enter Old SIM PIN Code** screen, enter the current SIM PIN and press  under OK.

NOTE: The default SIM PIN is 0000.

- 7** At the **Enter New SIM PIN Code** screen, enter a new 4- to 8-digit SIM PIN and press  under OK.

- 8** At the **Re-enter New SIM PIN Code** screen, re-enter the new SIM PIN to confirm, and press  under OK.

Unlocking the PIN

If you forget your PIN and unsuccessfully enter it three times, access to your phone will be blocked.

NOTE: Before you begin, obtain the PIN Unlocking Key (PUK) code from Nextel Customer Care, then read and understand the PIN unblocking sequence. When entering the key press sequence, each key press must occur within 5 seconds of the prior key press.

| | |
|---|---|
|  Caution | <p>If you unsuccessfully enter the PUK code ten times, the SIM card is permanently blocked and must be replaced. If this happens, all data will be lost. You will get a message to contact your service provider. Contact Nextel Customer Care for assistance. If the SIM card is blocked, the /80s phone only allows outgoing Emergency calls.</p> |
|---|---|

To unblock the PIN:

- 1** Press     .

- 2** Enter the 8-digit PUK code.

- 3** Press .

4 Enter a new 4- to 8-digit SIM PIN and press .

5 Re-enter your SIM PIN and press .

If you entered the codes properly, the **SIM Unlocked** screen displays.

Removing/Inserting the SIM Card



Caution

If you remove your SIM card and insert another SIM card into your phone, the following information is erased when you use the phone with the new SIM card:

- Datebook events
- Recent Calls list
- Voice Notes
- Voice names for Phonebook entries and Shortcuts
- Call Forwarding settings
- Call filtering settings in Styles
- Net Mail alerts
- Information stored in Memo

All Phonebook information will remain stored on your original SIM card.



Caution

Do not touch the gold-colored areas of the SIM card.

To avoid loss or damage, do not remove your SIM card from your phone unless absolutely necessary.

1 With phone powered off, remove the battery. See “Detaching the Battery” on page 9.

- 2 With the back of the phone exposed and facing up, locate the SIM cover and gently push it to the right. Lift the cover up.

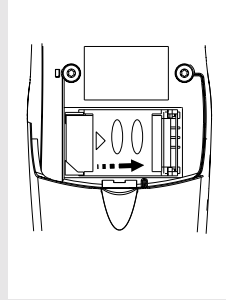

- 3 To insert the SIM card, *very carefully* place it in its holder with the *gold contact side facing down*.

NOTE: The cut angled corner on the SIM card should be facing the cut corner of the receptacle.

To close the SIM card cover, push it down and slide it to the left until it clicks into place.

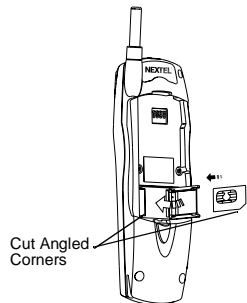

- 4 To remove the SIM card, slide the SIM card cover to the right and lift up (as in step 2). *Very carefully* lift the SIM out of its holder. *Do not touch the gold-colored areas of the SIM card.*

NOTE: Protect the SIM card as you would any delicate object. When the SIM card is not in the phone, you should store it in something protective, such as a mailing envelope.

Keypad Lock



The i80s phone includes a Keypad Lock feature that enables you to quickly lock the phone's keypad to avoid inadvertently pressing keys or placing calls. Once Keypad Lock is activated, you can only perform the following tasks:

- receive incoming calls, messages, and alerts
- turn your phone on and off
- unlock the keypad

NOTE: Emergency calls cannot be placed while Keypad Lock is activated.

Before locking your phone's keypad, you may want to read this entire section to learn how to respond to incoming calls, messages, and alerts.

Activating Keypad Lock



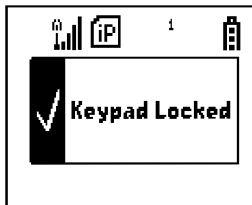

From the idle screen, press  . The message **Keypad Locked** displays on your phone.





Whenever a key is pressed while in Keypad Lock mode, the unlock instructions display briefly.

Receiving Incoming Calls

When you receive an incoming phone call (see “Receiving a Phone Call” on page 60), Keypad Lock is temporarily disabled.



Press  under YES or press  to answer the call. When you end the call, the **Recent Calls** list appears. Press  or press  under EXIT to reactivate Keypad Lock and return to the idle screen.

Or,

Press  under NO or press  to send the call to Voice Mail and reactivate Keypad Lock.

Receiving Nextel Direct Connect Calls

When you receive an incoming Private Call, Group Call, or Call Alert (see “Direct Connect” on page 101), Keypad Lock is temporarily disabled.





- 1 Press and hold the Push-To-Talk (PTT) button on the side of the phone. Begin talking after the phone emits a chirping sound. Release the PTT button to listen.
- 2 When you end the call, the **Recent Calls** list appears. Press  or press  under EXIT to reactivate Keypad Lock and return to the idle screen.

Receiving New Voice Mail

When you receive new Voice Mail (see “Nextel Voice Mail” on page 79), Keypad Lock is temporarily disabled.

When **New VoiceMail Message** displays, press  under EXIT to return to the idle screen and reactivate Keypad Lock.

Or,





Press  under CALL to access Voice Mail. Once you have finished, press  to exit Voice Mail. The **Recent Calls** list displays. Press  or press  under EXIT to reactivate Keypad Lock and return to the idle screen.

Receiving New Text Messages

When you receive new Text Messages (see “Text and Numeric Messaging” on page 96), Keypad Lock is temporarily disabled.

When **New Text Message** displays, press  under EXIT to return to the idle screen and reactivate Keypad Lock.

Or,





Press  under READ to read the message. Press  under SAVE or DELETE. Once you have finished, press  or press  under EXIT to reactivate Keypad Lock and return to the idle screen.

Receiving New Net Mail



When you receive new Net Mail (see “Two-Way Messaging” in the *Nextel Wireless Web User’s Guide* for more information), Keypad Lock is temporarily disabled.

When **New Browser Message** displays, press  under EXIT to return to the idle screen and reactivate Keypad Lock.

Or,

Press  under GOTO. Press  under View. Press  under OK or Reply. Once you have finished, press  until you reactivate Keypad Lock and return to the idle screen.

Deactivating Keypad Lock

From the idle screen, press  . The message **Keypad Unlocked** displays briefly.

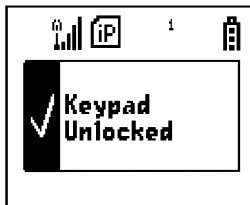

Status of Your i80s Phone

Your i80s phone has a status light that displays on the top of the phone. The status light indicates the status of your connection.







| Status Light Indicator | i80s Phone Status |
|------------------------|---|
| Solid Red | Signing on to the network. Please wait. |
| Flashing Red | No service or out of coverage area. If you are in a coverage area, keep your phone on and it will attempt to connect to the network every two minutes. If the phone does not connect after 15 minutes or more, contact Nextel Customer Care. |
| Flashing Green | In service/Ready to use. NOTE: Nextel Direct Connect is only available in your home calling area. |
| Solid Green | In use. |

My Information

You can select **My Info** from the main menu to display or edit the following:

- Name — enter your name in this field.
- Private ID — your Private ID is displayed in this field. Your Private ID is your Nextel Direct Connect number and is composed of three parts: Area ID * Network ID * Member ID. For example: **999*999*9999**.
NOTE: The asterisks are part of the Private ID.
- Phone Numbers of Lines 1 and 2 — your phone's numbers are displayed in these fields. Your phone number is automatically entered when you receive your first phone call.
- IP Addresses — these fields display the IP addresses you use to access the Internet with your phone.
- Circuit Data Number (Ckt) — you can enter your circuit data number in this field.

Viewing/Editing My Information

| | |
|---|--|
| 1 | From the idle screen, press  . |
| 2 | Press  to scroll to My Info . Press  under SELECT. The My Information screen displays. |
| 3 | Use  to scroll through the fields. |
| 4 | To edit the displayed information, press  under CHANGE. Edit information as desired, and press  under OK to save the changes. To return to the idle screen, press  under EXIT. |

Using T9® Text Input



Your i80s phone has embedded software, called T9® Text Input, that makes typing on a phone keypad much like typing on a computer keyboard: it eliminates the traditional “multi-tap” method of text entry. As you type, you press only one key per letter. T9 Text Input matches your keystrokes to words in its linguistic database of approximately 60,000 words and proper names. You may also store additional words you frequently use in your own user database, which is incorporated into the T9 database.

T9 Text Input is available when you are typing text into your phone (for example, in the Phonebook or Datebook) and while using Nextel Wireless Web services.

T9 Text Input Entry Modes

Four text entry modes are available in T9 Text Input: Alpha, Word, Symbols, and Numeric. When you are using T9 Text Input, an icon in the top right corner of your phone’s display screen (next to the battery strength indicator icon) indicates the T9 Text Input entry mode you are using:

| Icon* | T9 Entry Mode Name | Used For... |
|---|--------------------|---|
|  | Alpha | Standard “multi-tap” keypad text entry. |

| | | |
|---|----------------|--|
|  | Word | Entering words and punctuation with one key-press per character. |
|  | Symbols | Entering punctuation and symbols such as “@” or “?”. |
|  | Numeric | Entering keypad numbers. |

* T9 icons do not display while you are using Nextel Wireless Web services.

Choosing a Text Entry Mode on Wireless Web

When you are using Nextel Wireless Web services, T9 Text Input becomes available whenever you access a screen that requires you to enter text. The right display option on your the phone’s screen indicates your current T9 Text Input text entry mode:

- **ALPHA** and **alpha** for Alpha mode
- **WORD** or **word** for Word mode
- **SYM1**, **SYM2**, **SYM3**, or **SYM4** for Symbols mode
- **NUM** for Numeric mode



To change text entry modes, press the  under the current text entry mode until the desired mode displays.

NOTE: The rest of the instructions for using T9 Text Input apply only to entering text in applications other than Nextel Wireless Web applications (for example, Phonebook or Datebook). See the Nextel Wireless Web User’s Guide for instructions on using T9 Text Input for Nextel Wireless Web services.

Choosing a Text Entry Mode





You can select your text entry mode from a menu available whenever the phone is displaying a screen that requires you to enter text (for example, the **Name** screen or **Title** screen).

To choose a text entry mode:

| | |
|----------|--|
| 1 | <p>From any screen that requires text input, press  to access the Entry Method menu.</p> <p>A check mark appears next to the current text entry mode. When you access a screen that requires text input, the default text entry mode is Alpha.</p> |
| 2 | <p>Press  to scroll to the desired text entry mode.</p> |
| 3 | <p>Press  under SELECT.</p> <p>The phone returns to the text entry screen. An icon displays indicating the active text entry mode.</p> |

Choosing a Language

To change the language of the T9 Text Input database:





| | |
|----------|--|
| 1 | <p>From any screen that requires text input, press  to access the Entry Method menu.</p> |
| 2 | <p>Press  to scroll to Languages.</p> |
| 3 | <p>Press  under SELECT.</p> |
| 4 | <p>Press  to scroll to the language you want T9 Text Input to use.</p> |
| 5 | <p>Press  under SELECT.</p> |

NOTE: This feature is not available when using T9 Text Input with Nextel Wireless Web services.

Using Alpha Mode

To enter text (letters and numbers) while in Alpha text entry mode:

- Press any key on the alphanumeric keypad to enter the letters and numbers on that key. For example, to enter the letter Y, press  three times.

- Press  or press and hold the key to capitalize a letter.
- Pause briefly to leave the currently displayed character in place and move on to the next place in the text entry field.
- Press  or to create a space in the text entry field.
- Press  under DELETE to delete one character. Press and hold  under DELETE to delete an entire entry.



Using Word Mode

In Word mode, T9 Text Input analyzes the letters on the keypad button you press and arranges them to create words. As you type, T9 Text Input matches your keystrokes to words in its database and will display the most commonly used matching word.

Special Key Functions

Some of your phone's keys assume different functions while in T9 Text Input Word mode.

Backspace and Erase

Press  under DELETE once to backspace or to erase a single character. Press and hold  under DELETE to erase the entire text entry field.

Space

Press  once to accept a word and insert a space when entering text.



Next Word in Database

Press  to display more words in the database that match the keystroke sequence you entered.

Shift and Caps Lock

Press  to make the next letter typed uppercase (Shift), to make all subsequent letters types uppercase (Caps Lock), or to go back to lowercase letters.

These icons appear in the top row of your display screen:

-  for Shift to uppercase
-  for Caps Lock

When neither of these icons appear, letters typed are lowercase.

Punctuation

In Word mode, T9 Text Input uses Smart Punctuation to quickly apply basic rules of grammar to insert the correct punctuation within a word and at the end of a sentence.

Press  to insert punctuation. One of eight basic punctuation symbols will be inserted (, , - ' @ : ? ;).

Press  to change the inserted punctuation symbol to another of the eight basic punctuation symbols.

Press  to accept the punctuation and continue typing.





NOTE: Additional punctuation symbols are available in Symbols mode.

Entering a Word

To enter a word using Word mode:

1 Choose Word as your text entry mode.

2 Type a word by using one key press per desired letter.

For example, to type “test” press    .

NOTE: The displayed word may change as you type it. Do not try to correct the word as you go. Type to the end of the word before editing.

3 After you have finished typing, if the word that appears is not the desired word, press  to change the word on the display to the next most likely word in the database.

Repeat until the desired word appears.

If the desired word does not appear, you can add it to the database of words by deleting the displayed word and using the following the instructions in “Adding Words to the User Database” on page 29.

Adding Words to the User Database



To add words to the T9 database:

| | |
|---|--|
| 1 | Change from Word text entry mode to Alpha text entry mode (see “Choosing a Text Entry Mode” on page 25). |
| 2 | Type the word using Alpha text entry mode. |
| 3 | Return to Word text entry mode. |
| 4 | Press  to add a space. The word you typed in Alpha text entry mode is now in the database. |

NOTE: You cannot store alphanumeric combinations, such as Y2K.

Using Symbols Mode

To use Symbols text entry mode:

| | |
|---|---|
| 1 | Choose Symbols as your text entry mode. A row of 32 symbols appears along the bottom of your phone’s display screen, just above the display options and menu icon. (Press  to view the complete row.) |
| 2 | Press  to highlight the symbol you want to enter into the text entry field. |
| 3 | Press  under SELECT to enter the symbol. |

Using Numeric Mode

To use Numeric text entry mode, choose Numeric as your text entry mode and press the number buttons on your keypad to enter numbers.

Display Essentials

Your i80s phone's display screen tells you what you need to know as you use your phone.

This section includes:

| | |
|----------------------------|---------|
| Display Screen | Page 31 |
| Status Icons | Page 32 |
| Text Display Area | Page 34 |
| Call Information Icons | Page 34 |
| Menu Icon | Page 34 |
| Display Options | Page 34 |
| Navigating Menus and Lists | Page 35 |
| Main Menu Options | Page 36 |

Display Screen

Any time your phone is powered on, the display screen provides you with information and options. The display screen consists of:

- status icon rows — the top two rows display status. See “Status Icons” on page 32.
- text display area — displays up to four lines of text and icons. See “Text Display Area” on page 34.
- menu icon — see “Menu Icon” on page 34.
- display options — see “Display Options” on page 34.

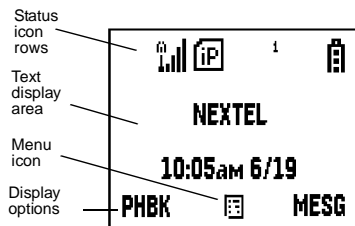

Idle Screen

The idle screen displays any time the phone is powered on, but not engaged in some activity.





The idle screen displays NEXTEL, the time and date, and any active styles (see “Styles” on page 156). You must start at the idle screen to access many of your phone’s features and functions.











Press  to access the idle screen at any time.

Status Icons

Status icons provide you with information about your phone and its functions. These icons are *context sensitive*; meaning, the icons that appear depend on the task you are performing.

Status icons appear in the two rows at the top of the display screen. Some appear at all times. Others appear only when your phone is engaged in certain activities or when you have activated certain features.

| Icon | Indicates... |
|---|---|
|  | Battery Strength — remaining battery charge. More bars on the battery indicate a greater charge. See “Battery Charging Status” on page 10. |
|  | Signal Strength — strength of the network signal. More bars next to the antenna indicate a stronger signal. Four bars is the maximum. |
|  | Active Line — currently active phone line; ¹ indicates Line 1 is active; ₂ indicates Line 2 is active. |
|  | Call Forward — phone is set to forward calls. See “Call Forwarding” on page 70. |
|  | Phone In Use — phone is connected on an active call. |

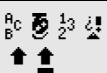
| | |
|--|--|
|  | Private In Use — number being called is a Private ID. |
|  | Talkgroup In Use — phone is active on a talkgroup call. |
|  | Packet Data Ready — phone is ready to receive data through a data cable. |
|  | Packet Data Activity — phone is transmitting data. |
|  | Mobile IP — phone is ready to access the Internet. |
|  | Secure Data — phone is accessing the Internet using a secure connection. |
|  | Text Message — you have one or more unread Text Messages or Net Mail messages. |
|  | Voice Mail — you have one or more unheard Voice Mail messages. |
|  | Speaker Off — phone's speaker is off. |
|  | Ring/Vibe — you have customized the way in which the phone is set to notify you when you receive calls and other types of messages. See “Ring Style and Notification Type” on page 143. |
|  | T9 Text Input — you are using T9 Text Input to enter text. See “Using T9® Text Input” on page 24. |





The icon of the main menu feature in use always appears in the top left of the status icon rows. For a list of the main menu icons, see “Main Menu Options” on page 36.

Text Display Area



The text display area shows menu options, messages, names, phone numbers, and other information.

Call Information Icons



The following icons appear on the left side of the text display area, providing you with information about your calls.

| Icon | Indicates... |
|---|--|
|  | In Call - phone is in an active call. |
|  | Incoming Call - phone is receiving an incoming call (not active). |
|  | Outgoing Call - phone is placing an outgoing call (not active). |
| | On Hold - phone has a call on hold. |
|  | End Call - phone has ended the active call. |

Menu Icon



The menu icon  appears on any screen from which a menu can be accessed. To access a menu, press  on your keypad.

Menus are context sensitive. The menu that appears depends on the screen you access it from, and the items on the menu apply to the task you are currently performing.

Press  or  from the idle screen to access the main menu.

Display Options

Two display options appear at the bottom of most screens. These options enable you to perform a wide variety of actions, including changing, saving and viewing information, running programs, and canceling previous actions. You activate a display option by pressing  below it.

NOTE: Throughout the User's Guide, the option keys  and  will be represented by .



The idle screen display options provide quick access to two main menu features. By default, the Phonebook (PHBK) and Messages (MESG) display options appear on the idle screen. You can control which display options appear on the idle screen using the phone's Personalize feature in the Settings menu (see "Changing Idle Screen Options" on page 148).

The display options on screens other than the idle screen cannot be customized.

Navigating Menus and Lists

The i80s phone is menu driven. By navigating menus, you access submenus which lead to all of the functions and features that are built into your phone. Use the menus to store calls, manage your Phonebook and Datebook, change your phone settings, browse the Internet, and more.

Some features include lists of names, numbers, or other information. These list items can be accessed the same way menu options are.

To access the items in a menu or list, scroll using the four-way navigation key at the top of your keypad. Scroll down by pressing the lower portion of the navigation key . Scroll up by pressing the upper portion of the navigation key . Holding down the appropriate part of the navigation key speeds up scrolling. If you continue scrolling after you have reached the bottom or top of a menu or list, you "wrap-around" to the opposite end.

If more items appear in a menu or list than can be displayed in the text area, a down arrow or up arrow appears in the left side of the screen indicating that more options may be accessed by scrolling up or down.

Down arrow

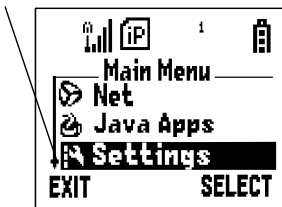











Up arrow











Main Menu Options

By default, the main menu options appear in the order shown in this table. You can change the order in which they appear by using the Personalize feature (see “Reordering Main Menu” on page 148).

To access the main menu, press  or  from the idle screen:

| Menu Item | Use to ... |
|---|--|
|  Net | Browse the Nextel Wireless Web. |
|  Java Apps | Run pre-installed and download custom Java applications on your phone. |
|  Settings | Customize your phone: Ring/Vibe, Phone Setup, In Call Setup, Security, Personalize, Initial Setup, Voice Volume, and Talkgroup Settings. |
|  VoiceNotes | Record personal messages or the incoming portion of phone calls to play back at a later time. |
|  Phonebook | Store and retrieve a list of stored entries for calling, editing, viewing, and deleting. |
|  Messages | Receive, store, access, and manage Voice Mail, Text Messages, and Net Mail. |
|  Call Forward | Settings for forwarding calls in various situations. |
|  Datebook | Schedule and organize events, by the day or the month, such as appointments and meetings. |
|  Memo | Input and store numbers to access later. |
|  Call Timers | Display the duration of phone calls, Private or Group Calls, circuit data use, and Kilobytes sent and received. |

| | |
|--|--|
|  Recent Calls | Access a list of the last 20 sent, received, or missed calls. Calls can be made from this list. |
|  Shortcuts | Associate a menu option with a number on the alphanumeric keypad for quick and easy access. |
|  My Info | View the name, Private ID, phone numbers for lines 1 and 2, IP address, and circuit data number of your phone. |
|  Styles | Create or edit a group of settings and save them as one for use in different environments. |
|  Call Alert | Store received Nextel Direct Connect Call Alerts to respond to at your convenience. |

To choose the highlighted main menu selection, press  under SELECT. To exit the main menu and return to the idle screen, press  under EXIT or press .

Phonebook

The Phonebook allows you to store up to 250 frequently used names and numbers.

When you store information in your Phonebook, it is saved on your SIM card. If you move your SIM card to another Nextel SIM-based phone, you can access information in your Phonebook from that phone.

NOTE: If you use a different SIM card in your phone, some information stored in the phone will be lost. See “Removing/Inserting the SIM Card” on page 18.

This section includes:

| | |
|--|---------|
| Phonebook Entries and Speed Dial Numbers | Page 40 |
| Phonebook Icons | Page 40 |
| Voice Names | Page 41 |
| Accessing Your Phonebook | Page 41 |
| About Phonebook Entries | Page 42 |
| Viewing Phonebook Entries | Page 42 |
| Sorting Phonebook Entries | Page 43 |
| Adding Phonebook Entries | Page 45 |
| Editing Phonebook Entries | Page 50 |
| Deleting Phonebook Entries | Page 51 |
| Pause Digit Entry | Page 51 |
| Plus Dialing | Page 52 |
| Address Book | Page 52 |

Phonebook Entries and Speed Dial Numbers

Your Phonebook can store multiple phone numbers to a single name. For example, you can enter someone's name into your Phonebook once and then add that person's home, office, mobile phone and fax numbers to the name. You can store up to seven phone numbers, one Private ID, and an IP address for each name.









Each phone number stored in your Phonebook is automatically assigned a Speed Dial number that corresponds to its location in your Phonebook. Each phone number uses one Speed Dial location, even if it is assigned to the same name as other phone numbers. The phone number stored in location 1 is assigned Speed Dial number 1, the phone number stored in location 2 is assigned Speed Dial number 2, and so forth, to location 250.

NOTE: Private IDs and Talkgroup numbers do not have associated Speed Dial numbers.

Phonebook Icons

Icons that appear to the right of entries in your Phonebook convey information about those entries.

When you enter a number in your Phonebook, you can designate the number's type using any of the following icons:

| | |
|---|------------|
|  | Mobile |
|  | Private ID |
|  | Work |
|  | Main |
|  | Home |
|  | Pager |
|  | Fax |
|  | Other |
|  | Talkgroup |



NOTE: The Mobile icon automatically appears to the right of the first number assigned to a name unless you choose another icon.

For more information on entering numbers into your Phonebook, see “Adding Phonebook Entries” on page 45.

The “picker” arrows appearing around the number type icon indicates multiple numbers stored under one name:



The Voice Name icon appearing to the left of one of the number type icons indicates that a voice name is associated with the Phonebook entry:



Voice Names



A voice name is an audio recording you assign to a number in your Phonebook by speaking into your *i80s* phone. You can then call the number by speaking the words you recorded into the phone. See step 6 of “Adding Phonebook Entries” on page 45 for more information on creating a voice name.



Accessing Your Phonebook

If PHBK is one of your display options:

| |
|---|
| From the idle screen, press  under PHBK. |
|---|

If PHBK is not one of your display options:

| | |
|---|---|
| 1 | From the idle screen, press  . |
| 2 | Press  to scroll to Phonebook . |
| 3 | Press  under SELECT. |

USER TIP: You can also access the **Phonebook** while you are on an active call. Press  then press  to scroll to **Phonebook** and press  under SELECT.

This brings you to the **Phonebook** screen. From this screen, you can view, sort, add, edit, and delete Phonebook entries, check Phonebook capacity, or make calls.

About Phonebook Entries

Each Phonebook entry may contain the following information:

- The name associated with the entry: Typically, this is the name of the person whose number you are storing in the Phonebook.
- The type of number to be stored: Mobile, Private, Work, Main, Home, Pager, Fax, Other, or Talkgroup. If you don't choose a type, the number is assigned type Mobile, unless a Mobile number has already been assigned to the name.
- The number to be stored: Every Phonebook entry must contain a number. This number may be any type of phone number, Private ID, or Talkgroup number.
- A Speed Dial number: You may accept the default Speed Dial number or assign a different one.
- A voice name audio recording for voice-activated dialing.

Viewing Phonebook Entries

Names with more than one number assigned to them appear with  surrounding the icon to the right of the name. For example, if you had stored a home and work number for Joe Smith, the entry for Joe Smith's home phone number would look like this:

Joe Smith 

When the name is highlighted, press  to scroll to the icons representing each of the numbers assigned to that name.

To view any of the numbers assigned to a name:

1 From the **Phonebook** screen, press  to scroll to the name associated with the number you want to see.

2 Press  to view the icons representing the numbers assigned to that name.

3 When the icon representing the number you want to view is displayed, press  under VIEW.

Or,

If there is a Private ID or a Talkgroup number stored for the entry, press . Then press  to scroll to **View** and press  under SELECT.

4 Press  to view the other numbers stored for this name.

Sorting Phonebook Entries

You can sort your Phonebook entries by:

- Name — the name you entered for the entry.
- Speed No. — the Speed Dial location of the entry.

NOTE: Private IDs and Talkgroup numbers cannot be accessed from the Phonebook when sorted by Speed Dial location.

- Voice Name — all entries with voice names appear at the top of the list.

To sort your Phonebook list:

- 1 From the **Phonebook** screen, press  to view the **Phonebook Menu** screen.



- 2 Press  to scroll to **Sort By**.

- 3 Press  under **SELECT**.

- 4 Press  to scroll to the desired sorting method: **Name**, **Speed No.**, or **Voice Name**.

- 5 Press  under **SELECT**.

Checking Phonebook Capacity

Your Phonebook can store up to 250 separate numbers. To see how many entries are stored in your Phonebook:

- 1 From the **Phonebook** screen, press  to view the **Phonebook Menu** screen.

- 2 Press  to scroll to **Capacity**.

- 3 Press  under **SELECT**.

The **Capacity** screen shows how many storage spaces in your Phonebook are in use and how many are empty.

Adding Phonebook Entries

Using the following instructions, you will enter the information in the order the items appear on the Phonebook **Entry Details** screen. However, you can enter this information in any order by pressing  to scroll through the items on the **Entry Details** screen.

You can leave any item blank (except number) or unchanged by pressing  to scroll past it on the **Entry Details** screen. Only a number is required for a valid Phonebook entry.



To cancel a Phonebook entry at any time, press  to return to the idle screen.

To add a Phonebook entry:

1 Access the **Entry Details** screen:

From the **Phonebook** screen, with [New Entry] highlighted, press  under SELECT.

Or,

From the **Phonebook** screen, press . Then press  to scroll to **New** and press  under SELECT.



2 If you want to assign a name to your Phonebook entry:

With the **Name** field highlighted, press  under CHANGE.

From the **Name** screen, enter the name using the alphanumeric keypad.

See “Using T9® Text Input” on page 24 for information about entering text into this field.

When you are finished, press  under OK.

The **Entry Details** screen returns with the **Type** field highlighted.

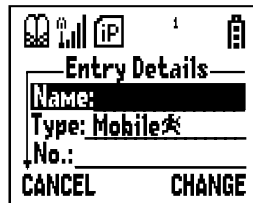

- 3 To accept the number type **Mobile**, press  to scroll to the **No.** field.

If you want to assign a number type other than **Mobile** to your Phonebook entry:

With the **Type** field highlighted, press  under **CHANGE**.

From the **Type Editor** screen, press  to scroll to the type of number you want to assign to the Phonebook entry.

Press  under **SELECT**.

The **Entry Details** screen returns with the **No.** field highlighted.



- 4 Assign a number to your Phonebook entry:

With the **No.** field highlighted, press  under **CHANGE**.

Type the number using the alphanumeric keypad. For phone numbers, use the 10-digit format. For Private IDs, use Area ID * Network ID * Member ID (the asterisks must be included as part of the Private ID).

To delete a digit, press  under **DELETE**.

See “Pause Digit Entry” on page 51 and “Plus Dialing” on page 52 for information on using these features when storing phone numbers in your Phonebook.

NOTE: The number can be up to 20 characters long.

When you are finished, press  under **OK**.

The **Entry Details** screen returns with the **Speed No.** field highlighted.

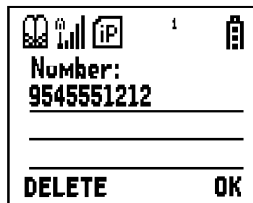

- 5 The default Speed Dial number assigned to the phone number is displayed in the **Speed No.** field. This is always the next available Speed Dial location.

NOTE: Private IDs and Talkgroup numbers do not have associated Speed Dial numbers.

To accept the default Speed Dial location, go to step 6.

If you want to assign the phone number to a different Speed Dial location:

With the **Speed No.** field highlighted, press under CHANGE.

Press under DELETE to delete the current Speed Dial number.

Type the new Speed Dial number using the alphanumeric keypad.

When you are finished, press under OK.

NOTE: If you change the Speed Dial number to one already in use, you will be prompted to overwrite the entry that is currently in that location. Pressing under YES will delete the existing entry from your Phonebook.



- 6 If you want to assign a voice name to the number:

With the **Voice Name** field highlighted, press  under RECORD.

As directed by the screen prompts, say and repeat the name you want to assign to the number. Speak clearly into the microphone.



USER TIP: For best results, use voice names such as “Joe Home” or “Susan Work” and record in a quiet environment.

An  icon appears in the **Voice Name** field indicating that the voice name has been recorded.

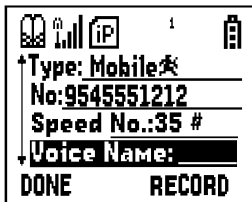
If you do not want to store a voice name for this number, continue to the next step.



- 7 If you want to store more numbers to the name associated with this Phonebook entry:

Press  to scroll to **MORE** at the bottom of the **Entry Details** screen and then press  under SELECT.

A new **Type** field appears for the additional number.

Enter the information for the additional numbers using step 3 through step 7.

NOTE: Each name in your Phonebook may have up to seven phone numbers, one Private ID and one IP address associated with it.



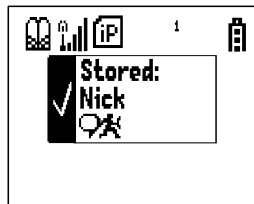

- 8 When you have entered all the information for this Phonebook entry, press  under DONE.



Storing Numbers Fast







Your phone gives you two ways to store numbers quickly: from the idle screen and from the Recent Calls list.

To store a number from the idle screen:







- 1 From the idle screen, use the alphanumeric keypad to enter the number you want to store. For phone numbers, use the 10-digit format. For Private IDs, use Area ID * Network ID * Member ID.
- 2 Press  to access the **Dialing Menu** screen.
- 3 With **Store Number** highlighted, press  under SELECT.

This displays the **Entry Details** screen with the **No.** field filled in with the number you typed.
- 4 If you want to add more information to the Phonebook entry, follow the applicable instructions in “Adding Phonebook Entries” on page 45.
- 5 Press  under DONE.





To store a number from the Recent Calls list:

- | | |
|----------|--|
| 1 | From the Recent Calls screen, press  to scroll to the number you want to store. |
| 2 | Press  under STORE. Or, Press  to access the Rec. Calls Menu . Press  to scroll to Store . Press  under SELECT. This displays the Entry Details screen with the No. field filled in with the number of the recent call. |
| 3 | If you want to add more information to the Phonebook entry, follow the applicable instructions in “Adding Phonebook Entries” on page 45. |
| 4 | Press  under DONE. |

Editing Phonebook Entries

- | | |
|----------|---|
| 1 | From the Phonebook screen, press  to scroll to the entry you want to edit. |
| 2 | Press  to view the Phonebook Menu . |
| 3 | Press  to scroll to Edit . |
| 4 | Press  under SELECT. The Entry Details screen displays. |
| 5 | Follow the applicable instructions in “Adding Phonebook Entries” on page 45 to edit the various fields. NOTE: To add additional numbers to an existing entry, press  to scroll to MORE . Press  under SELECT . Follow the applicable instructions in “Adding Phonebook Entries” on page 45. |

Deleting Phonebook Entries

| | |
|----------|---|
| 1 | From the Phonebook screen, press  to scroll to the entry you want to delete. |
| 2 | Press  to view the Phonebook Menu . |
| 3 | Press  to scroll to Delete Record or Delete Number . Delete Record deletes the name and all numbers associated with that name. Delete Number deletes the number associated with the icon that is currently displayed in the Phonebook list for the name. The name and all the other numbers will remain. |
| 4 | Press  under SELECT. A warning screen displays requiring you to confirm the deletion. |

Pause Digit Entry

When storing a number, you can program your phone so it will not only dial a number but also pause before entering another series of numbers such as a personal identification number (PIN) or password. This feature is particularly useful for accessing automated services such as voice mail and banking systems from your i80s phone.

Example: Let's say you have a company voice mail account that you frequently check while traveling. And, to access that account you must do the following:

- dial your work number
- press # while the voice mail greeting is being played
- enter your PIN to access your messages

You can program your phone to enter all of the above information for you by separating each entry with a pause. The stored data would look like this: 17035551234P#P1234. In this example, the first eleven digits represent the number that must be dialed to access your voice mail. The P represents a 3 second pause. The # interrupts your greeting. The second P represents another 3 second pause. The last four digits represent your PIN.

To create a three-second pause, follow the steps below:

Press and hold  for two seconds. The pause symbol (P) will appear on the display screen.

NOTE: You can enter up to 20 characters in a single entry, stored or dialed.

NOTE: You can program your phone to pause for more than 3 seconds. Performing the above step twice will program two pauses and cause your phone to wait 6 seconds before entering the next set of numbers.

Plus Dialing

This feature enables you to place an international call from most countries — without entering the local international access code. Use Plus Dialing for all Phonebook entries if you plan to travel outside the United States. Begin by following the instructions for “Adding Phonebook Entries” on page 45. Before you type the phone number to be stored:

- 1 Press and hold  for two seconds. A “0” appears, then changes to a “+”.

NOTE: The network translates the “+” into the appropriate international access code needed to place the call.

- 2 Enter the country code, city code, or area code (as needed), and phone number.
- 3 Follow the rest of the instructions for “Adding Phonebook Entries” on page 45.

Address Book

Manage your contact information with Address Book. Address Book provides easy maintenance and entry of contact information and access to that information from your i80s phone or nextel.com. Address Book is a Nextel Wireless Web service and requires the activation of a Nextel OnlineSM Service Plan. To order, contact Nextel Customer Care.

For instructions on how to use this application, see “Address Book” in the *Nextel Wireless Web User’s Guide*.

Digital Cellular

The *i80s* phone utilizes Nextel's All-Digital National Network for digital cellular service. You can also use your Nextel phone to roam internationally on other iDEN networks using Nextel Worldwide Service. See nextel.com for coverage.

This section includes:



| | |
|----------------------------------|---------|
| Making Phone Calls | Page 54 |
| Emergency Calling | Page 59 |
| Special Dialing Codes | Page 59 |
| Receiving a Phone Call | Page 60 |
| Transferring Calls to Voice Mail | Page 60 |
| Recent Calls | Page 61 |
| Call Timers | Page 64 |
| Hands-Free Speaker Phone | Page 65 |
| Mute | Page 66 |
| Call Waiting | Page 66 |
| Call Hold | Page 68 |
| Three-Way Calling | Page 69 |
| Call Forwarding | Page 70 |
| Caller ID | Page 74 |
| Alternate Line Service | Page 75 |
| Call Restrictions | Page 77 |
| Nextel 411 | Page 77 |

Making Phone Calls

Your i80s phone provides the following features for making phone calls:





- Direct Dial
- Phonebook
- Recent Calls
- Speed Dial
- Turbo Dial®
- Voice-Activated Dialing
- Last Number Redial
- TTY — your phone supports TTY devices and communications.

Using Direct Dial

- | | |
|---|--|
| 1 | From the idle screen, use the keypad to enter the 10-digit phone number you want to call. |
| 2 | Press  to place the call. |
| 3 | Press  to end the call. |

NOTE: See “Plus Dialing” on page 52 for information on making international calls.

If you make a mistake:

- To clear one digit, press  under DELETE.
- To clear all digits, press and hold  under DELETE.
- To insert a digit, press  to move the cursor.
- To cancel, press .



Making Calls from the Phonebook

After you have entered phone numbers into your Phonebook, you can use these numbers to make phone calls. For information on entering numbers into your Phonebook, see “Adding Phonebook Entries” on page 45.

To make calls from the Phonebook:

- 1 From the idle screen, if PHBK is one of your display options, press  under PHBK.

Or,



From the idle screen, press , then press  to scroll to **Phonebook**. Press  under SELECT.

- 2 Press  to scroll through the names in your Phonebook.

Or,



Use the alphanumeric keypad to enter the first letter of the name and press  to scroll through the names beginning with that letter.

Stop when the name of the person you want to call is highlighted.





- 3 If more than one number is stored for the person you want to call,   appears around the icon to the right of the person's name.

Press  to scroll through the icons representing the numbers stored for that person.

Or,

Press  under VIEW to view the number. You can press  to scroll through other numbers stored for this person.

Or,

If there is a Private ID stored for this person, press . When the **Phonebook Menu** appears, press  to scroll to **View** and press  under SELECT. Then press  to scroll to the number you want to call.

For more information on assigning multiple numbers to one person, see “Adding Phonebook Entries” on page 45.

4 Press  to place the call.



5 Press  to end the call.

Making Calls from the Recent Calls List

Your phone stores the numbers of the last 20 calls you received or sent in the Recent Calls list.

1 From the idle screen, press .

Or,

From the idle screen, press . Press  to scroll to **Recent Calls**. Press  under SELECT.

2 Press  to scroll through the list of received or sent recent calls until you reach the desired call.

3 To view additional information about the call:

Press  under VIEW.

Or,



Press  to access the **Rec. Calls Menu**. Then press  to scroll to **View** and press  under SELECT.

4 Press  to place the call.

5 Press  to end the call.

Using Speed Dial

Each phone number stored in your Phonebook is assigned a Speed Dial number. You can use the Speed Dial number to quickly place a call.

- | | |
|---|--|
| 1 | From the idle screen, enter the Speed Dial number assigned to the phone number you want to call. |
| 2 | Press  . The number's Phonebook entry information will display. |
| 3 | Press  to place the call. |
| 4 | Press  to end the call. |

Using Turbo Dial

Turbo Dial allows you to quickly call the numbers in your Phonebook associated with Speed Dial numbers 1 through 9 by pressing and holding the corresponding numeric key on the keypad.

Press and hold a number key (1 through 9).

NOTE: Turbo Dial cannot be accessed while the browser is active, nor while Keypad Lock or SIM Lock is active.

Making Calls Using Voice-Activated Dialing

If you have recorded a voice name for a phone number in your Phonebook (see “Voice Names” on page 41), you can use this feature to call the number.

USER TIP: If you have difficulty making phone calls using a voice name, try assigning a longer voice name to the number. For example, if the voice name “Joe” fails to place a call to Joe Smith’s number, try assigning the voice name “Joe Smith” to the number.

1 From the idle screen, press and hold  near the bottom of your phone until the phone beeps and the **Say Name Now** screen appears, then release.

2 Speaking into the microphone, say the voice name assigned to the phone number you want to call.

3 Your phone will play the name back to you.

The call will automatically be placed.

Last Number Redial

Press and hold  to redial the last number you called.

NOTE: If you receive “System Busy, Try Later,” press  to redial the number automatically. You will hear a ring-back tone when the call is successfully placed.

Placing International Phone Calls

When making an international call, you can either enter the international access code directly (for example, 011 in the United States) or use Plus Dialing.

You can make international calls from your Phonebook if you have stored the numbers with Plus Dialing. See “Adding Phonebook Entries” on page 45 and “Plus Dialing” on page 52 for more information.

NOTE: Your service default is “International Calls Restricted.” Contact Customer Care to obtain international dialing access.

To make an international call using Plus Dialing:

1 Press and hold  for two seconds. A “0” appears, then changes to a “+”.

NOTE: The network translates the “+” into the appropriate international access code needed to place the call.

2 Enter the country code, city code, or area code (as needed), and phone number.

3 Press  to place the call.

4 Press  to end the call.

Making TTY Calls

You can use your phone to make calls using a TTY device.

When you make TTY call, the call begins in the TTY mode you last selected. You can change the TTY mode during a call. For more information on choosing a TTY mode, see “Setting TTY Mode” on page 154.





To make a call using a TTY device:

1 Connect one end of a 2.5mm cable into the jack on the phone. (To locate the jack, see page 6.) Connect the other end of the cord into your TTY device.

2 Enter the phone number you wish to call and press .

Emergency Calling

Your phone supports emergency calling. Emergency calls can be made even when the SIM card is blocked or not in the phone.

To place an emergency call, press    . You will be connected to the nearest emergency dispatch center. If you are on an active call, you must end it before calling 911.



NOTE: If you have enabled the Keypad Lock feature, you must unlock the phone's keypad before any calls can be made, including 911 emergency calls.

Special Dialing Codes

Non-Emergency Numbers

Nextel supports many “non-emergency” numbers (such as #77, 311,...) provided by local and state governments. These numbers are used to report non-emergency incidents. If the situation includes imminent danger or loss of life, you should dial 911.

Telecommunications Relay Service

Nextel supports services for communicating with speech and/or hearing impaired individuals. You can press    to reach a local Telecommunications Relay Center. You will then be connected to your destination number. Relay service works through a Communications Assistant who reads messages typed into a TDD/TTY device by a speech or hearing impaired individual to you. The Communications Assistant then types your spoken messages to the hearing or speech impaired individual. Telecommunications Relay Service is available 24 hours a day, seven days a week, and every call is strictly confidential.

NOTE: Using 711 to reach Telecommunications Relay Service may not be available in all areas.



Receiving a Phone Call

Incoming calls are indicated by a ring, vibration, or backlight illumination.



The screen will display:

- the caller's name if stored in your Phonebook, or
- the 10-digit number if Caller ID information is available.

Otherwise, the screen will display **Incoming Call**.

Press  or any key on the keypad, or press  under YES to answer the call.

Transferring Calls to Voice Mail

Press  or press  under NO while your phone is ringing to transfer incoming calls directly to Voice Mail. The  icon will appear on the idle screen to remind you that you have a stored Voice Mail message.

Ending a Phone Call

Press .

NOTE: The Recent Calls list displays briefly after each phone call.

Recent Calls

The Recent Calls feature stores the numbers of the 20 most recent calls you have made and received, including Private and Group Calls. You can access Recent Calls to:



- view your recent calls
- store numbers to the Phonebook
- delete recent calls
- call numbers on the Recent Calls list

NOTE: The Recent Calls list displays briefly after each call.



Recent Calls Icons

For Private Calls, Group Calls, and numbers stored in your Phonebook, an icon appears to the right of the name or number indicating the Phonebook type of the number used in the call. See “Phonebook Icons” on page 40 for more information about Phonebook types.

For phone calls, an icon appears to the left of the name or number indicating the type of call:

-  indicates an incoming call
-  indicates an outgoing call
-  indicates a missed call. (Missed calls appear on your Recent Calls list only if you have Caller ID.)

For Nextel Direct Connect calls, an icon appears to the left of the name or number indicating the type of call:

-  indicates a Private Call
-  indicates a Group Call



Viewing Recent Calls

If the number of the recent call is stored in your Phonebook, the name associated with the number displays.

To view your Recent Calls list:

1 From the idle screen, press .

Or,

From the idle screen, press . Press  to scroll to **Recent Calls**. Press  under SELECT.

2 Press  to scroll the list of recent calls.

Getting Detailed Information About Recent Calls

To get more information about a recent call:

1 From the **Recent Calls** screen, press  to scroll to the call you want more information on.

2 Press  under VIEW.





Or,

Press  to access the **Rec. Calls Menu**. Then press  to scroll to **View** and press  under SELECT.

The screen that appears displays information such as the name associated with the number of the recent call, the number, date, time, and duration of the call.

Storing a Recent Call Number to the Phonebook

To store a number from the Recent Calls list to the Phonebook:





- | | |
|----------|---|
| 1 | From the Recent Calls screen, press  to scroll to the number you want to store. |
| 2 | Press  under STORE . Or, Press  to access the Rec. Calls Menu . Then press  to scroll to Store and press  under SELECT . This displays the Phonebook Entry Details screen with the No. field filled in with the number of the recent call. |
| 3 | If you want to add more information to the Phonebook entry, follow applicable the instructions in “Adding Phonebook Entries” on page 45. |

Calling From the Recent Calls List





See “Making Calls from the Recent Calls List” on page 56.

Deleting Recent Calls

To delete a recent call:



- | | |
|----------|--|
| 1 | From the Recent Calls screen, press  to scroll to the call you want to delete. |
| 2 | Press  to access the Rec. Calls Menu . |
| 3 | Press  to scroll to Delete . |
| 4 | Press  under SELECT . |
| 5 | Press  under YES to confirm the deletion. |

To delete all calls on the Recent Calls list:

| | |
|---|---|
| 1 | From the Recent Calls screen, press  to access the Rec. Calls Menu . |
| 2 | Press  to scroll to Delete All . |
| 3 | Press  under SELECT . |
| 4 | Press  under YES to confirm the deletion. |

Accessing Voice Notes From Recent Calls

You can access the Voice Notes feature from Recent Calls and use it to record spoken messages that you can listen to later.

| | |
|---|---|
| 1 | From the Recent Calls screen, press  to access the Rec. Calls Menu . |
| 2 | Press  to scroll to Voice Notes . |
| 3 | Press  under SELECT . |

For more information about Voice Notes, see “Voice Notes” on page 127.

Call Timers



Call Timers measure the duration of your phone calls, Private or Group Calls, and circuit data use, as well as the number of Kilobytes sent and received by your phone.

The **Call Timers** menu displays the following options:





- **Last Call** — displays the duration of your most recent phone call.
- **Phone Reset** — keeps a running total of your phone call minutes, until you reset it.
- **Phone Lifetime** — displays the total minutes of all your phone calls.
- **Prvt/Grp Reset** — keeps a running total of all of your Private and Group Call minutes, until you reset it.

- **Prvt/Grp Lifetime** — displays the total minutes of all your Private and Groups Calls.
- **Circuit Reset** — keeps a running total of all of your circuit data use, until you reset it.
- **Circuit Lifetime** — displays the total minutes of all of your circuit data use.
- **Kbytes Reset** — keeps a running total of the number of Kilobytes sent and received by your phone, until you reset it.

To view the **Call Timers** menu:

| | |
|---|---|
| 1 | From the idle screen, press  . |
| 2 | Press  to scroll to Call Timers . |
| 3 | Press  under SELECT. |

To view or reset a Call Timers option:

| | |
|---|--|
| 1 | From the Call Timers menu, press  to scroll to the Call Timers option you want to view or reset. |
| 2 | Press  under SELECT. |
| 3 | If the feature does not include an option to reset or you do not wish to reset the option, press  under DONE when you are finished viewing. To reset a feature, press  under RESET. When the confirmation screen appears, press  under YES to confirm the reset. |

NOTE: The values displayed by Call Timers are not intended for billing purposes.

Hands-Free Speakerphone

This feature provides the convenience of a hands-free speakerphone for holding impromptu meetings and placing safer phone calls. The speakerphone option (SPKR) is available whenever you are on an active phone.

NOTE: During speakerphone operation, you may either speak or listen, but you cannot do both at the same time.

To turn the speakerphone on:

While on an active call, press  under SPKR.

Or, press .

While speakerphone is on, **Spkrphone On** appears in the text display area.

To turn the speakerphone off:

Press  under SPKR.

Or, press .

Mute

Use the Mute feature to listen to incoming audio without allowing sound from your phone's microphone to be transmitted over the phone line.

To turn mute on:

While on an active call, press  under MUTE.

While mute is on, UNMUTE appears as a display option and **Mute** appears in the text display area.

To turn mute off:

Press  under UNMUTE.

Call Waiting

Call Waiting allows you to receive a second call while you are talking on the phone. You can switch between calls so you never have to miss a call. By default, Call Waiting is always on unless you turn it off for a specific call.

If you're on a call and you receive a second call, you will:

- hear a tone
- see a message on your display informing you of another incoming call

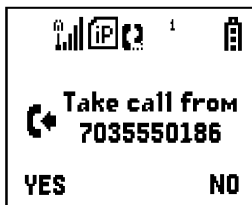

Accepting Calls

Press under YES. The first call is placed on hold.

To end the active call and accept the second call:

Press . Then press or press under YES.

Switching Between Calls

When you accept a second call while you are talking on the phone, your display shows the name or number of each call. An icon appears to the left of each name or number indicating the call is on hold or active .

Press under SWITCH to switch between calls.



Declining Calls

Press under NO. If you subscribe to Voice Mail, the call will be forwarded to your Voice Mail box.

Ending the Active Call

Press .

Turning Off Call Waiting

If you do not want to be interrupted during a call, you can turn Call Waiting off prior to making/receiving a call.

1 From the idle screen, press . Press  to scroll to **Settings**, and press  under SELECT.

2 Press  to scroll to **In Call Setup** and press  under SELECT.

3 Press  to scroll to **Call Waiting** and press  under CHANGE.

4 Press  to scroll to **Off** and press  under SELECT.

Call Waiting is now disabled for the next call. It will automatically reset to **On** when you end the call.

Call Hold

When you are on an active call, you can place the call on hold and make a second call.

To place an active call on hold:



1 Press  to access the **Call Menu**.

2 Press  to scroll to **Hold**.

3 Press  under SELECT.

4 If you have not placed a second call, you can resume this call by pressing  under RESUME.

To place a second call while the first call is on hold:

- 1 Enter the second phone number you want to call. Or select the number from your Phonebook by pressing  and selecting **Phonebook**.
- 2 Press  to place the second call.

To toggle between the two calls:

Press  under SWITCH.



To end the active call:

Press . The call on hold becomes active.

Three-Way Calling

Using Three-Way Calling, you can combine two ongoing phone calls into one conversation. While on an active call, you can make a second call and combine the two calls.

To make a three-way call:

- 1 Place or receive a phone call.
- 2 While on the call, press  to access the **Call Menu**.
- 3 Press  to scroll to **3 Way**.
- 4 Press  under SELECT. The first call will be placed on hold.

5 Enter the second phone number and press  to place the second call.

Or, access the number from your Phonebook:

Press  and then press  to scroll to **Phonebook**.

Press  under SELECT.

To place the call, see “Making Calls from the Phonebook” on page 54.

6 After you reach the second individual, press .

7 Press  to scroll to **3 Way**.

8 Press  under SELECT. Both calls will appear on your display.

Call Forwarding

Nextel’s Call Forwarding features forward calls to the number you designate. The following Call Forwarding options are available:

- **All Calls** — When this option is turned on, all calls will be sent automatically to a number you specify. When this option is turned off, your **Detailed** options will be activated.
- **Detailed** — Choosing this option enables you to forward calls you missed to Voice Mail or other numbers, depending on why you missed each call:
 - **Busy** — your phone is engaged in other activities.
 - **No Answer** — you do not answer. The phone will ring 4 times before forwarding the call.
 - **Unreachable** — your phone is out of coverage or powered off.

NOTE: For you to receive Voice Mail messages, the All Calls option must be set to Off and the Detailed options must be set to your Voice Mail access number. Your Voice Mail access number is the first six digits of your 10-digit phone number followed by 6245. This is the default setting.

You can forward Line 1 and Line 2 independently. For more information on using two lines, see “Alternate Line Service” on page 75.

When your phone is set to forward All Calls, one of the following icons appears on the top row of your display screen to indicate the call forwarding option you have chosen:

| Icon | Indicates... |
|------|---|
| | Line 1 is active; calls from Line 1 are being forwarded. |
| | Line 1 is active; calls from Line 2 are being forwarded. |
| | Line 1 is active; calls from Line 1 and Line 2 are being forwarded. |
| | Line 2 is active; calls from Line 1 are being forwarded. |
| | Line 2 is active; calls from Line 2 are being forwarded. |
| | Line 2 is active; calls from Line 1 and Line 2 are being forwarded. |

Turning On Call Forwarding

1 Press then press to scroll to **Call Forward**.

2 Press under SELECT.

3 At the **Call Forward** screen, the **Forward** field is highlighted. Press under CHANGE.

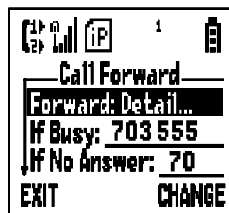



4 Press  to scroll to **All Calls**.

5 Press  under SELECT.

6 Press  to scroll to the **To** field and press  under CHANGE.



7 To activate a call forwarding number:

If you have never used Call Forwarding before, the **Forward** screen appears. To enter a call forwarding number, type the number on your phone's keypad or press  under SEARCH to select from numbers stored in your phone. Press  under OK.

Or,

If you have used Call Forwarding before, the call forwarding number you last used is displayed. Press  under CHANGE to access the **Forward** screen.

To forward your calls to this number, press  under OK.

To forward your calls to a different number, press and hold  under DELETE to erase the displayed number. Type the new number on your phone's keypad or press  under SEARCH to select from numbers stored in your phone. Press  under OK.



Your calls will now be forwarded to the number you selected.



Turning Off Call Forwarding

1 Press  then press  to scroll to **Call Forward**.

2 Press  under SELECT.

The **Call Forward** screen displays with the **Forward** field highlighted.

3 Press  to scroll to the **To** field and press  under CHANGE.

4 Press  to scroll to **Off** and press  under SELECT.



You will now receive all calls on your phone. When you are unavailable, your calls will be forwarded according to your **Detailed** Call Forwarding settings. By default, the **Detailed** option is set to forward your calls to Voice Mail.

Setting Call Forwarding to Voice Mail



In most cases, turning off Call Forwarding restores your ability to receive Voice Mail messages when you are unavailable (see “Turning Off Call Forwarding” on page 72). If you have completed those steps but are still not able to receive Voice Mail messages, you can reset Call Forwarding to Voice Mail.

For you to receive Voice Mail messages, Call Forwarding must be set to **Detailed** with your Voice Mail access number:

1 Press  then press  to scroll to **Call Forward**.

2 Press  under SELECT.

The **Call Forward** screen displays with the **Forward** field set to **Detailed**.

3 Press  to scroll to the **If Busy** field and press  under CHANGE.

4 The call forwarding number you last used is displayed. Press  under CHANGE. If this is your Voice Mail access number (the first six digits of your 10-digit phone number followed by 6245), go to step 7.

| | |
|---|--|
| 5 | Press and hold <input type="radio"/> under DELETE to erase the displayed number. |
| 6 | Enter your Voice Mail access number. Your Voice Mail access number is the first six digits of your 10-digit phone number, followed by 6245. (For example 7035556245.) |
| 7 | Press <input type="radio"/> under OK. |
| 8 | Repeat step 3 through step 7 for the If No Answer field and the If Unreachable field. |
| 9 | When finished, press <input type="radio"/> under EXIT. |

NOTE: You can use the Detailed setting to forward calls to other numbers if desired. However, it is recommended that you leave Detailed set to the Voice Mail access number and use the All Calls setting if you wish to forward your calls to another number.

Additional Phone Features

In addition to the standard features that are included for all Nextel Digital Cellular subscribers, there are also several features available for an additional monthly or per-use fee. See the following sections for more information on these services. Contact Nextel Customer Care for additional information.

NOTE: Some services are not available outside of the continental United States.

Caller ID

If you subscribe to Caller ID, your phone automatically displays the phone number or name (if the 10-digit phone number is stored in your Phonebook) of the person calling (unless blocked by the caller), enabling you to decide whether to take the call or forward it to Voice Mail.

NOTE: Caller ID information is not available on all calls.

Displaying the Caller's Name

A caller's name is displayed if you have entered the person's number into your Phonebook (see "Adding Phonebook Entries" on page 45). Otherwise, the caller's phone number will be displayed.

Maintaining Your Privacy with Per-Call and Per-Line Blocking

Nextel provides two methods to prevent those you call from seeing your number on their own Caller ID displays.

NOTE: Your Nextel phone number cannot be blocked from calls made to 911, 800, 855, 866, 877, 888 or other toll-free phone numbers.

Per-Call Blocking

You can block delivery of your phone number to other Caller ID units for a single phone call.

To set:

Press    before dialing the call.

Per-Line Blocking

You can permanently block delivery of your phone number on every call you make. You must order this feature by contacting Nextel Customer Care.

To disable on a per-call basis:

Press    before the call.

Alternate Line Service

As an Alternate Line customer, you will be given a separate phone number for each line. With alternate lines, you can separate business and personal calls, or designate one as a priority line.









Nextel Mobile Messaging and Nextel Wireless Web services use the Line 1 phone number. You only need to subscribe to Caller ID or Voice Mail once — these services will be available on both lines. Forwarding Line 2 to Line 1 will send Line 2 incoming calls directly to Voice Mail without ringing.

The following settings are independent for each phone line. When you enable one of these settings, it applies only to the active line:

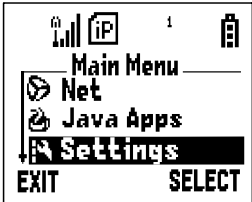
- Call Forwarding
- Ring/Vibe
- In Call Setup
- Call Timers
- Auto Answer

Selecting the Alternate Line

From the idle screen:

| | |
|--|---|
| <p>1 Press , then press  to scroll to Settings. Press  under SELECT.</p> |  |
| <p>2 Press  to scroll to Phone Setup. Press  under SELECT.</p> | |
| <p>3 With the current line highlighted, press  under CHANGE.</p> | |
| <p>4 Press  to scroll to the desired line and press  under SELECT.</p> | |

Receiving Calls on Your Alternate Line

You can receive calls on either line, regardless of the active line setting. The active line icon (1 or 2) displays to indicate which line the call is being received on.

Call Restrictions

You can prevent your phone from making or receiving specific types of calls. Nextel currently offers three types of Call Restrictions:

- no long distance calls allowed
- no incoming calls
- no outgoing calls (except 911)

Contact Customer Care for more information.

Nextel 411

Nextel 411 provides friendly services for on-the-go professionals including:

White Page Listings

You can request a telephone number for any person, business, or government agency in the continental United States and Hawaii. Operators can also provide address information if available.

Yellow Page Listings

You can ask the operator to perform a search by category if the specific business name is unknown. For example, you can request information for the nearest copy center to your hotel while on business travel.

Nationwide Call Completion

Nextel 411 operators can connect you to any listing in the continental United States and Hawaii. If requested, the operator will stay on the line while connecting to the number.

Driving Directions

Nextel 411 operators are able to provide directions to reach a specific destination. Operators will work with you to determine your starting point and provide clear directions to the destination.

Restaurant Reservations





Nextel 411 operators can assist in finding a restaurant and then coordinate reservations. A Nextel 411 operator will confirm your reservation information through a return phone call. For your convenience, the reservation will be in your name.

Movie Listings and Showtimes

Nextel 411 operators have access to movie listings at most theaters in the continental United States and Hawaii. You only need to ask for a specific movie or movie theater to get current movies, locations or showtimes. Additional information such as running time, synopsis, and ratings are also available. Showtimes and listings are available 24-48 hours in advance.

Local Event Information

You can request information on local events such as sporting events, concerts, state and county fairs and other current events. Nextel 411 operators can provide dates, times, and locations for these events.

Simply dial     from your Nextel phone anywhere within the continental United States and Hawaii.

Nextel Voice Mail

Nextel Voice Mail is a flexible, easy-to-use system that takes messages when you're not available — so you never miss an important call.

This section includes:

| | |
|--------------------------------|---------|
| Setting Up Your Voice Mail Box | Page 79 |
| Receiving Voice Mail Messages | Page 80 |
| Using Voice Mail | Page 81 |
| Advanced Voice Mail Features | Page 86 |
| Nextel Voice Mail Tree | Page 94 |

This section covers the most commonly used Voice Mail features. Once you log into Voice Mail, there are a number of innovative features you can access. They are also covered in this section. After you access Voice Mail, an automated system tells you each menu option and which button to press to make a menu selection. See “Nextel Voice Mail Tree” on page 94.

Setting Up Your Voice Mail Box

You must set up your Voice Mail box before you can listen to messages. The following steps will tell you how to setup your mailbox. Before getting started, see “Recording Your Active Greeting” on page 85 for information you may want to include in your greeting.

- 1 Using your Nextel phone, dial your 10-digit Nextel Personal Telephone Number (PTN). For example: 7035557777.

If you are calling from a phone other than your *i80s* phone, dial your 10-digit Nextel Personal Telephone Number (PTN). When you hear the greeting, press * to access your Voice Mail box.

- 2 The system will prompt you to **Enter your password**. Enter the last seven digits of your Nextel Personal Telephone Number. For example: 5557777. This is your temporary password.

3 Follow the system instructions to:

- Create a new four- to seven-digit password (see “Changing Your Password” on page 84).
- Record your name (see “Recording Your Name” on page 85).
- Record a greeting (see “Recording Your Active Greeting” on page 85).

4 When the system says **Enjoy using Nextel Voice Mail**, your mailbox is set up.

Receiving Voice Mail Messages

Your phone is pre-programmed with default Call Forwarding settings to forward your calls to Voice Mail when you are not available. The default setting is Detailed with the If Busy, If No Answer and If Unreachable fields set to your Voice Mail access number. If you have subscribed to the Voice Mail and have set up your Voice Mail box, but are not receiving your Voice Mail messages, see “Setting Call Forwarding to Voice Mail” on page 73.

New Message Indicators



When you receive a new message:

- **New VoiceMail Message** will display on the screen.



- Your phone will alert you every 30 seconds until you press under CALL or under EXIT.

Transferring Calls to Voice Mail

Press  or press  under NO while your phone is ringing to transfer incoming calls directly to Voice Mail. The  icon will appear on the idle screen to remind you that you have a stored Voice Mail message.

Using Voice Mail



Logging Into Voice Mail

To log into Voice Mail, you must first access the Message Center on your phone.

If MESSG is one of your display options:

From the idle screen, press  under MESSG.



If MESSG is not one of your display options:

- 1 From the idle screen, press .
- 2 Press  to scroll to **Messages**.
- 3 Press  under SELECT.

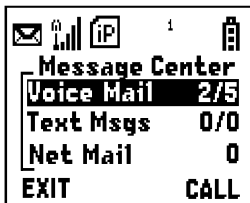
The **Message Center** screen displays numbers of new and total Voice Mail messages.







From the **Message Center** screen, log into Voice Mail:



- | | |
|----------|--|
| 1 | Press  to scroll to Voice Mail . The numbers of new and total Voice Mail messages display. |
| 2 | Press  under CALL to log into Nextel Voice Mail. Calling displays as you are connected to the network. NOTE: If you hear a message that says, “Enter the phone number of the subscriber you are trying to reach,” enter your own 10-digit Nextel Personal Telephone Number. When the greeting plays, press  to receive a password prompt. |
| 3 | When prompted, enter your password. |



NOTE: You must receive a message before you can access Voice Mail for the first time from your 80s phone. (Tip: You can leave yourself a message.)

Main Voice Mail Menu



You are at the main Voice Mail menu when you hear the options listed below.

- To play your messages, press . (This option plays only if you have new or saved messages.)
- To record a message, press .
- To change your greeting, press .
- To access your personal options press .

If you press  while you are in a sub-menu, you will go to the previous menu. If you press  , you will go to the main Voice Mail menu.

From the main Voice Mail menu, press  to exit Voice Mail. At any time, you may end the call by pressing .

Playing Messages

When you receive a new Voice Mail message, you can either listen to it immediately or later. Press  under CALL to listen now or press  under EXIT to listen later.

Options available while listening to your messages:

| | |
|-------------------------------------|-------------------------------------|
| Replay previous six seconds. | Press 1 (1) |
| Rewind to beginning of message. | Press 1 (1) 1 (1) |
| Pause/continue the current message. | Press 2 (abc) |
| Fast forward 6 seconds. | Press 3 (def) |
| Fast forward to end of message. | Press 3 (def) 3 (def) |
| Play the date and time stamp. | Press 5 (jkl) 5 (jkl) |

Options available while a message is playing or after it has played:

| | |
|--|---------------------------------------|
| Copy the message to another subscriber. (See “Recording, Copying and Replying to Messages” on page 88.) | Press 6 (mno) |
| Delete the message. | Press 7 (pq r) 7 (pq r) |
| Reply to a message. | Press 8 (tuv) |
| Save the message. | Press 9 (wxyz) 9 (wxyz) |
| Skip to the next message. | Press # (0) |

Saving and Deleting Messages

While a message is playing or after you have finished listening to it, you can save it or delete it. To save a message, press **9** (wxyz). To delete a message, press **7** (pq r). To have messages automatically saved, see “Automatic Playback” on page 87.

Messages that are not saved or deleted remain in your mailbox as new messages. All messages are automatically deleted after 30 days.

Recovering Deleted Messages

To retrieve deleted messages, press ***4** **3**. This option only applies to the current Voice Mail session. If you end the call, the messages will be permanently deleted.

| | |
|---|--|
|  <p>Caution</p> | <p>After exiting the Voice Mail session, you cannot recover deleted messages.</p> |
|---|--|

Changing Your Password

To change your current password:

- | | |
|---|--|
| 1 | From the main Voice Mail menu, press *4 4 to access Personal Options. |
| 2 | Press 4 4 to access Personal Preferences. |
| 3 | Press 1 . to modify password. |
| 4 | Enter your new password. This password must be all numbers. It must be 4 to 7 digits long. |
| 5 | Press *4 *4 to return to the main menu. |

NOTE: If you forget your password, contact Customer Care.

| | |
|--|--|
|  <p>WARNING</p> | <p>For security purposes, it is recommended that you do not choose sequential or repeated digits like 1-2-3-4 or 5-5-5-5 for your password.</p> |
|--|--|

Recording Your Name

When you send, reply to, or copy a message, your name response precedes the message. To record or re-record your name at any time:

| | |
|---|--|
| 1 | From the main Voice Mail menu, press (4gnl) to access Personal Options. |
| 2 | Press (4gnl) to access Personal Preferences. |
| 3 | Press (3def) to access the Record Your Name option. |
| 4 | Press (2abc) to record your name. |
| 5 | Press (*) (*) to return to the main menu. |

Recording Your Active Greeting

Through Nextel Voice Mail service, there are a number of ways in which people can reach you. You may want to include one or all of the following options in your greeting so that callers will know they are available.

- Press 1 to send a numeric message.
- Press 2 to send an operator assisted message. (This option is available only if you are a subscriber of Operator Assisted Messaging. Contact Nextel Customer Care for more information.)
- Press # to skip the greeting and record a message immediately.

To record or alter your greeting at any time:

| | |
|---|--|
| 1 | From the main Voice Mail menu, press (3def) to change your greeting. |
| 2 | Press (1.') to play, press (2abc) to record or re-record, or press (3def) to delete your active greeting. |
| 3 | Record your greeting and press (#) when you have finished. |
| 4 | Press (*) (*) to return to the main menu. |

Advanced Voice Mail Features

Multiple Greetings

Nextel Voice Mail service allows you to have up to five different greetings. You can designate which greeting will be your active greeting at any given time. For example, instead of your regular greeting, you may wish to activate a different greeting for days when you are out of the office or on vacation.

The greeting that was recorded during your initial Voice Mail box setup is Greeting 1. This is your default active greeting.

Recording Additional Greetings

To record additional greetings:

| | |
|---|---|
| 1 | From the main Voice Mail menu, press (3^{def}) to access the Greetings menu. |
| 2 | Press (4^{gnt}) to modify greetings. |
| 3 | Enter the greeting number you wish to create or modify. |
| 4 | Press (2^{abc}) to record a greeting. |
| 5 | Record your greeting and press (#) when you have finished. |
| 6 | Press (*) to return to the main menu. |

Selecting Your Active Greeting

To select your active greeting:

| | |
|---|---|
| 1 | From the main Voice Mail menu, press (3^{def}) to access the Greetings menu. |
| 2 | Press (3^{def}) to select another greeting to be active. |
| 3 | Enter the number of the greeting that you would like to be active. |
| 4 | The system will confirm your active greeting number. |

5 Press **1** to play your active greeting.

6 Press ***4*** to return to the main menu.

Greetings Schedule

You can choose to have your greetings automatically activated based on a pre-determined time schedule. By activating the Greeting Schedule, Greetings 1, 2 and 3 will automatically play according to the time schedule listed below.

| | | |
|------------|-----------------------|---|
| Greeting 1 | Evenings and Weekends | 5:00 pm -- 7:59 am, Monday -- Friday 24-hours, Saturday and Sunday |
| Greeting 2 | Weekday Mornings | 8:00 am -- 11:59 am Monday -- Friday |
| Greeting 3 | Weekday Afternoons | Noon -- 4:59 pm Monday -- Friday |

Activating Your Greeting Schedule

To activate the greeting schedule:

1 From the main Voice Mail menu, press **3** to access the Greetings menu.

2 Press **9** to activate your greeting schedule.

3 Press ***4*** to return to the main menu.

Automatic Playback

By default, the playback mode of your Voice Mail service is set to Normal. Nextel's Automatic Playback feature automatically plays and saves new messages when you log in. To activate Automatic Playback:

1 From the main Voice Mail menu, press **4** to access Personal Options.

2 Press **4** to access Personal Preferences.

3 Press **2abc** to access Playback Preferences.

4 Press **2abc** to switch between Automatic and Normal Playback.

5 Press ***←*←** to return to the main menu.

Changing the Playback Order of Messages

With Nextel Voice Mail service, you can select the order in which you want unheard messages to be played. You may listen to the last received message first, or you may listen to the first received message first. To select the order in which new messages should be played:

1 From the main Voice Mail menu, press **4ghl** to access Personal Options.

2 Press **4ghl** to access Personal Preferences.

3 Press **2abc** to access Playback Preferences.

4 Press **1.:** to switch between the playback orders.

5 Press ***←*←** to return to the main menu.

Recording, Copying and Replying to Messages

These functions allow you to record and send, reply to, or copy a message to an assigned destination address or Group List number.

If you record a complete or partial message, but do not send it, Nextel Voice Mail service will refer to this message as an “in preparation” message. Before sending messages you may want to see “Creating Group Lists” on page 90.

To record and send a message:

1 From the main Voice Mail menu, press **2abc** to access Record a Message.

2 Record your message and press **#** to end the message.

| | |
|---|--|
| 3 | Press 9 ^{MP} at the prompt to indicate that you want to send the message or press 5 ^{JKL} for Delivery Options. |
| 4 | Enter the mailbox number and/or group list number(s). (A mailbox number is the 10-digit Nextel Personal Telephone Number of a Nextel customer. The name of the recipient plays if it is recorded.) |
| 5 | Press # to send. |
| 6 | Press *4 *4 to return to the main menu. |

NOTE: You can only send messages using this method to Nextel customers in your home market.

Delivery Options

After you have created a message, you can assign the message to a category before you send it. Below is a list of the options that can be applied to a message:

| | |
|------------------------------|--|
| Urgent | Recipient will hear this message before other messages. |
| Private | Recipient cannot copy the message to another mailbox or phone number. |
| Notification of Non-Delivery | You will be notified if the recipient has not listened to your message by a certain date and time. |
| Future Delivery | You can specify a time and date (up to three months in advance) for the message to be delivered. (See “Time and Date Charts” on page 93.) Important: Once a message has been sent for future delivery, it cannot be retrieved or deleted. |

To set a special delivery option:

| | |
|---|---|
| 1 | After recording your message but before sending it, press 5 ^{JKL} for Delivery Options. |
|---|---|

| | |
|----------|---|
| 2 | <p>Press the number that corresponds with the desired delivery option:</p> <ul style="list-style-type: none"> • Press (1) for Urgent. • Press (2abc) for Private. • Press (3def) for Notification of Non-Delivery. At prompt, specify time and date. • Press (4ghi) for Future Delivery of Messages. At prompt, specify time and date. • Press (9xyz) to send the message immediately. |
| 3 | The list of options will be presented again. Select an additional option or press (9xyz) to send the message. |
| 4 | Enter the destination mailbox or Group List number of the recipient(s). |
| 5 | Press (#) to send. |
| 6 | Press (*)(*) to return to the main menu. |

Working With Group Lists

The Group List feature enables you to create a list and assign it a unique name. Then, you can add mailbox numbers, group lists or individuals — by name — to the list. Once you create a list you can send a voice message to everyone on the list by entering the group list number. You can have up to 40 group lists. Each list can hold up to 50 addresses.

Creating Group Lists

To set up a Group List:

| | |
|----------|---|
| 1 | From the main Voice Mail menu, press (4ghi) to access Personal Options. |
| 2 | Press (2abc) to access your Group Lists. |
| 3 | Press (2abc) to create a Group List. |
| 4 | Enter the one- or two-digit group list number and press (#). |

| | |
|---|--|
| 5 | Record a name for the list and press # . |
| 6 | Select group members by mailbox number, Group List, or name. |
| 7 | Press # to save all entries added to the list. |
| 8 | Press *4*4 to return to the main menu. |

Modifying a Group List

| | |
|---|---|
| 1 | From the main Voice Mail menu, press 4 gnl to access Personal Options. |
| 2 | Press 2 abc to access Group Lists. |
| 3 | Press 4 gnl to modify a Group List. |
| 4 | Enter the number of the Group List you want to modify. |
| 5 | Press 1 . to add a new recipient. |
| 6 | Press # to save your changes. |
| 7 | Press *4*4 to return to the main menu. |

Deleting a Group List

| | |
|---|---|
| 1 | From the main Voice Mail menu, press 4 gnl to access Personal Options. |
| 2 | Press 2 abc to access Group Lists. |
| 3 | Press 3 def to delete a Group List. |
| 4 | Enter the number of the Group List you want to delete. The system will play the name of the Group List. |

5 Press (#) to delete the list.

6 Press (*)(*) to return to the main menu.

Message Forwarding

This feature allows you to program your phone to automatically forward incoming messages to another Nextel customer's mailbox. There are three types of forwarding: Immediate, Silent and Delayed. They are described below:

- **Immediate Forwarding** - Caller is notified that the message will be forwarded.
- **Silent Forwarding** - Caller is not notified that the message will be forwarded.
- **Delayed Forwarding** - If a caller's message is not retrieved after a certain amount of time, the message will automatically be forwarded to another mailbox or telephone number.

1 From the main Voice Mail menu, press (4 ght) to access Personal Options.

2 Press (5 jkl) to modify Forwarding Options.

3 Select the applicable option below:

- To create a forwarding number, press (2 abc).
- If you have already created a forwarding number, press (2 abc) to modify the number.
- To enable or disable Message Forwarding, press (3 def).
- To change the forwarding type, press (4 ght).
 - Press (1 .) for Immediate Forwarding
 - Press (2 abc) for Silent Forwarding
 - Press (3 def) for Delayed Forwarding

4 Press (*)(*) to return to the main menu.

NOTE: You can only forward messages to Nextel customers in your home market.

Time and Date Charts

Time and Date Charts can be referenced for specific tasks throughout Nextel Voice Mail service.

24-hour Clock

Nextel Voice Mail service uses a 24-hour clock:

NOTE: To compute the 24-hour clock for pm, add 1200.

Below is a list of hours translated into 24-hour time:

| | | | | | | |
|---------------|----------|---------|---------|----------|---------|----------|
| 12-hour Clock | 12:00 am | 4:00 am | 8:00 am | 12:00 pm | 4:00 pm | 10:00 pm |
| 24-hour Clock | 0000 | 0400 | 0800 | 1200 | 1600 | 2200 |

Dates

All dates must have 4 digits in the MM/DD format (2 digits for the month and 2 digits for the day). January is 01, February is 02, etc. The first day of the month is 01, the second day of the month is 02, etc. For days of the week, Sunday is 1, Monday is 2, etc.

Nextel Voice Mail Tree

To access Voice Mail:

From your own Nextel phone, follow the instructions in the User's Guide that came with your phone.

From any other phone:

1. Dial your own 10-digit Nextel phone number.
If you hear "Please enter the number of the subscriber you are trying to reach", enter your own 10-digit Nextel phone number.
2. Press * when you hear your greeting.
3. Enter your password.

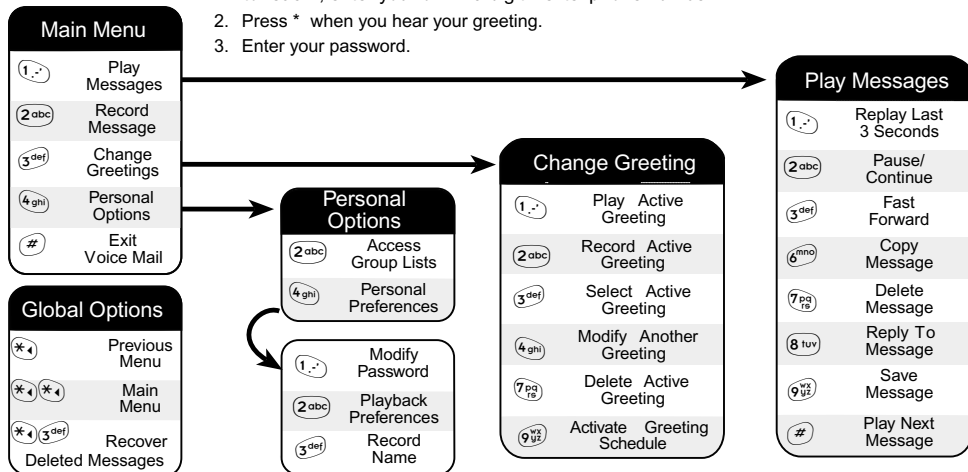

Messages

Your Nextel phone offers choices in Messaging Services — Voice Mail and Nextel Mobile Messaging (Text and Numeric Messaging and Nextel Two-Way Messaging).

Nextel Voice Mail is a flexible, easy-to-use system that takes messages when you're not available — so you never miss an important call!

Nextel Mobile Messaging helps keep you in touch with co-workers and customers, regardless of where you travel on the Nextel National Network:

- Text and Numeric Messaging allows others to send you a message that is displayed directly on your Nextel phone.
- Two-Way Messaging uses the Nextel Wireless Web to provide immediate contact, even when you can't make or take a call. Two-Way Messaging allows you to send, receive, and respond to text messages quickly and discreetly.

The main topics covered in this section are listed below:

| | |
|----------------------------|---------|
| Message Center | Page 95 |
| Nextel Voice Mail | Page 96 |
| Text and Numeric Messaging | Page 96 |
| Nextel Two-Way Messaging | Page 99 |

Message Center



The Message Center enables you to access all messaging services through one screen.

To access the Message Center:

If MESH is one of your display options:



From the idle screen, press  under MESH.

If MMSG is not one of your display options:

- | | |
|----------|--|
| 1 | From the idle screen, press  . |
| 2 | Press  to scroll to Messages . |
| 3 | Press  under SELECT. |

The **Message Center** screen displays the number of messages you have in each message service — **Voice Mail** (Voice Mail), **Text Msgs** (Text and Numeric Messages), and **Net Mail** (Two-Way Messages and other Wireless Web-based mail).

To access any message service:

- | | |
|----------|--|
| 1 | From the Message Center screen, press  to scroll to the message service you want to access. |
| 2 | Press  under the display option on the right. This option varies depending on the message service selected. |

Nextel Voice Mail

See “Nextel Voice Mail” on page 79.

Text and Numeric Messaging

With Nextel Text and Numeric Messaging, Nextel will:

- Allow text (alpha) messages up to 140 characters in length.
- Allow numeric messages up to 20 characters in length when a caller press “1” at your Voice Mail greeting.
- Accept your messages even if you are unavailable, if your phone is turned off, or if you are busy on another call.
- Alert you of a new text or numeric message, even if you are on another call.
- Store a message if you are using Nextel Direct Connect and deliver it upon completion of the call.
- Store the message if you are outside of the coverage area and deliver it as soon as you are back in a coverage area.

- Attempt continuous delivery of messages until successful, for up to 7 days.

With Nextel Text and Numeric Messaging, your Nextel phone will:

- Refer to text and numeric messages as Text Messages.
- Stamp the message with the time and date the message was left.
- Store up to 16 messages at a time, that will remain until you delete them.

NOTE: “Mail Waiting, Memory Full” displays when 16 message registers are full. (Messages must be erased before you can receive others.)



- Allow for “Auto Call Back” of a phone number that is included within a message, by pressing . If the message contains two phone numbers, Auto Call Back will dial the last number.

Notification of New Messages

When you receive a new message:

- **New Text Message** will display on the screen.



- Your phone will alert you every 30 seconds until you press  under READ or  under EXIT.

Accessing New Messages

When you receive a message, you can view it immediately or later.

Viewing a Message Immediately

- 1 Press  under READ. The message displays.



2 If the message fills more than one screen, use  to scroll through the rest of the message.

3 Press  under SAVE to save the message.

Or,

Press  under DELETE to delete the message.



Viewing a Message Later

Press  under EXIT. The  icon will appear on the idle screen to remind you that you have a stored message.

Viewing Stored Messages

1 In the **Message Center** screen, press  to scroll down to **Text Msgs.** The number of new messages and the total number of messages are displayed.

2 Press  under SELECT. The **Text Msg Inbox** screen appears.

3 Press  to scroll to the message you want to read and press  under READ.

4 If the message fills more than one screen, use  to scroll through the rest of the message.

5 Press  under SAVE to save the message.

Or,

Press  under DELETE to delete the message.

Sending a Message

Nextel's Text and Numeric Messaging feature includes four options for sending messages: Web Messaging on nextel.com, Email Messaging, Numeric Messaging, and Operator Assisted Messaging.

Web Messaging on nextel.com

Nextel's Web Messaging enables you to send a message to yourself, someone else, or a group of Nextel customers. It also includes a "Schedule For Later" option, which allows you to schedule messages to be sent at a specific time and date. You can also check on the delivery status of your messages.

For more information or to send a Web message, go to nextel.com and click on **Send a Message** or **Nextel Mobile Messaging**.

Email Messaging

From any email account, type the 10-digit phone number of a Nextel customer in the **To** field and add **@messaging.nextel.com** (for example, 7035551234@messaging.nextel.com). The entire message can be up to 140 characters.

Numeric Messaging

- The caller must press "1" during your Voice Mail greeting.
- Once the caller presses "1", only a numeric message can be sent.

*Operator Assisted Messaging**

- The caller can press "2" during your Voice Mail greeting. Or, call 1-800-NEXGRAM (1-800-639-4726). Outside of the U.S., call 1-858-279-8495.
- A text message can be sent immediately or scheduled for future delivery.
- The operator will send the message.

** The Operator Assisted Messaging feature is required. There is also an additional charge for this service. For more information, contact Customer Care.*

Nextel Two-Way Messaging

Your i80s phone refers to Two-Way Messages as Net Mail.

With Two-Way Messaging, you can:

- Receive messages (up to 500 characters in length) with built-in replies and respond to them at the touch of a button.
- Respond to messages when you're in a meeting or noisy location.
- Create and store your own frequently used responses that let you send informative answers without keying in text.

- Send messages to one individual from your phone or contact several at once from any email system or nextel.com.

To activate this service, contact Nextel Customer Care. For additional information on how to use this service, see “Two-Way Messaging” in the *Nextel Wireless Web User’s Guide*.

Nextel Direct Connect®

Nextel Direct Connect is a digital two-way radio feature that allows you to communicate with your co-workers and clients for a fraction of the cost of traditional cellular calls.

With Nextel Direct Connect, you can use the Private Call feature to contact an individual. You can use the Group Call feature to contact a group of people designated as a Talkgroup.

In addition, Nextel has created Nextel Business Networks®, which allows you to communicate with individuals outside your company. These Networks link Nextel customers in similar industries or geographic regions. So, if you need to reach a client, vendor, or contractor instantly, work smarter by joining the Nextel Business Networks. For more information, call 1-888-NEXTEL2 (1-888-639-8352).

NOTE: Nextel Direct Connect® is only available in your home calling area.

This section includes everything you need to take advantage of Nextel Direct Connect (digital two-way radio) service:

| | |
|--------------|----------|
| Private Call | Page 102 |
| Call Alerts | Page 104 |
| Group Call | Page 108 |

Private Call

There are several ways to reach an individual using Nextel Direct Connect.

Whether you dial the person's Private ID directly or use a number stored in your Phonebook or Recent Calls list, you must have the individual's Private ID to use Nextel Direct Connect. To learn how to store names and numbers, see "Phonebook" on page 39.

USER TIP: To find out your own Private ID, see "My Information" on page 23.

NOTE: When dialing or storing a Private ID, the asterisks must be entered as part of the Private ID in order to make a Nextel Direct Connect Private Call.





NOTE: The Recent Calls list displays briefly after each Private or Group Call.

Making a Private Call from the Keypad

- | | |
|---|--|
| 1 | Enter the Private ID of the person you are trying to call. Be sure to enter Area ID * Network ID * Member ID. |
| 2 | Press and hold the Push-To-Talk (PTT) button on the side of the phone. Begin talking after the phone emits a chirping sound. |
| 3 | Release the PTT button to listen. |





Making a Private Call from the Phonebook

If you have stored a person's Private ID in your Phonebook (see "Adding Phonebook Entries" on page 45), you can use your Phonebook to make a Private Call to that person:

- | | |
|---|---|
| 1 | From the idle screen, press  or press  . |
| 2 | Press  to scroll to Phonebook . Press  under SELECT. |
| 3 | From the Phonebook screen, press  to scroll through the names until the desired name is highlighted. |

- | | |
|---|---|
| 4 | Press and hold the PTT button on the side of the phone. Begin talking after the phone emits a chirping sound. |
| 5 | Release the PTT button to listen. |

Making a Private Call from the Recent Calls List

- | | |
|---|--|
| 1 | From the idle screen, press  . |
| 2 | Press  to scroll to Recent Calls . Press  under SELECT. |
| 3 | From the Recent Calls screen, press  to scroll through the names and numbers to the desired name or Private ID. |
| 4 | Press and hold the PTT button on the side of the phone. Begin talking after the phone emits a chirping sound. |
| 5 | Release the PTT button to listen. |

For more information on Recent Calls, see “Recent Calls” on page 61.

Making Private Calls Using Voice-Activated Dialing

If you have recorded a voice name for a Private ID in your Phonebook (see “Voice Names” on page 41), you can use this feature to call the number.

- | | |
|---|--|
| 1 | From the idle screen, press and hold  near the bottom of your phone until the phone beeps and the Say Name Now screen appears, then release. |
| 2 | Speaking into the microphone, say the voice name assigned to the Private ID you want to call. |
| 3 | Your phone will play the name back to you. Press the PTT button when prompted. |

USER TIP: If you have difficulty making calls using a voice name, try assigning a longer voice name to the number. For example, if the voice name “Joe” fails to place a call to Joe Smith’s number, try assigning the voice name “Joe Smith” to the number.

Receiving a Private Call

When you receive a Private Call, your phone emits a chirping sound. **Private in Use** and the Private ID or the name of the caller (if stored in your Phonebook) display on the screen.

To respond to a Private Call:

- | | |
|---|--|
| 1 | Wait for the caller to stop speaking. |
| 2 | Press and hold the PTT button. Begin talking after the phone emits a chirping sound. |
| 3 | Release the PTT button to listen. |

Storing Private IDs

For information on how to store Private IDs to your Phonebook, see “Adding Phonebook Entries” on page 45.

For information on how to quickly store Private IDs, see “Storing Numbers Fast” on page 49.

Call Alerts

You can send a Call Alert, which lets recipients know that you would like to talk with them. When you send an alert, the recipient will receive a series of beeps and your name or Private ID will appear on the display.



Placing a Call Alert from the Keypad

- | | |
|---|---|
| 1 | Enter the Private ID of the person you want to call. Be sure to enter Area ID * Network ID * Member ID. |
|---|---|

2 Press  under ALERT. The **Ready to Alert** screen displays.

3 Press and hold the PTT button until **Alert Successful** displays. The recipient's phone sounds the alert intermittently until the user of the phone answers, queues, or clears the alert.

Placing a Call Alert from the Phonebook

1 From the idle screen, press  or press .

2 Press  to scroll to **Phonebook**. Press  under SELECT.

3 From the **Phonebook** screen, press  to scroll to the Phonebook entry for the person you want to alert.

4 Press  under ALERT. The **Ready to Alert** screen appears.



5 Press and hold the PTT button until **Alert Successful** displays. The recipient's phone sounds the alert intermittently until the user of the phone answers, queues, or clears the alert.

Ready to Alert Screen



Ready to Alert is used to confirm your request for the alert and to prompt you to push the PTT button:

- If you press the PTT button, the Call Alert is sent, and the phone displays the **Recent Calls** screen.
- For Call Alerts placed from the keypad, pressing  under CANCEL causes the phone to return to the dialing screen with the previously entered number displayed.

- For Call Alerts placed from the Phonebook, pressing  under CANCEL causes the phone to return to the **Phonebook** screen.
- If you do nothing, the phone will revert to the idle screen.

Receiving Call Alerts

When you receive a Call Alert, your phone emits a chirp and displays the name or Private ID of the caller. You can answer, queue, or clear the Call Alert:



- To answer the Call Alert, press the PTT button and begin talking after the phone emits a chirping sound.
- To queue the Call Alert, press  under QUEUE.
- To clear the Call Alert, press  under CLEAR.

NOTE: Until you answer, queue or clear the Call Alert, you will not receive any additional phone, Private or Group Calls.

Call Alert Queue



Call Alert queuing enables you to save up to eight Call Alerts in a list, or queue. To store a Call Alert in the Call Alert Queue, press  under QUEUE when you receive an incoming Call Alert.

Accessing the Call Alert Queue

| | |
|---|--|
| 1 | From the idle screen, press  . |
| 2 | Press  to scroll to Call Alert . |
| 3 | Press  under SELECT. The Call Alert Queue screen displays. |

Viewing Call Alert Date and Time

To find out the date and time a Call Alert was received:

| | |
|---|---|
| 1 | From the Call Alert Queue screen, press  to scroll to the desired Call Alert. |
| 2 | Press  to access the Call Alert Menu . |

3 Press  to scroll to **View**.

4 Press  under SELECT.

Sorting Call Alerts

To sort your Call Alerts by the order they were received:

1 From the **Call Alert Queue** screen, press  to access the **Call Alert Menu**.

2 Press  to scroll to **Sort By**.

3 Press  under SELECT.

4 Press  to scroll to **First on Top** or **Last on Top**.

5 Press  under SELECT.

Responding to a Call Alert From the Queue

1 From the **Call Alert Queue** screen, press  to scroll to the Call Alert you want to respond to. You can respond by sending a Call Alert or placing a Private Call.

2 To send a Call Alert, press  under ALERT and then press the PTT button.





Or,

To place a Private Call, press the PTT button.





The Call Alert will be removed from the queue.

Deleting a Call Alert From the Queue

To delete a Call Alert from the queue:

| | |
|---|---|
| 1 | From the Call Alert Queue screen, press  to scroll to the entry you want to delete. |
| 2 | Press  to access the Call Alert Menu . |
| 3 | Press  to scroll to Delete . |
| 4 | Press  under SELECT. |
| 5 | When the confirmation screen appears, press  under YES to delete the entry. |

To delete all Call Alerts from the queue:







| | |
|---|---|
| 1 | From the Call Alert Queue screen, press  to access the Call Alert Menu . |
| 2 | Press  to scroll to Delete All . |
| 3 | Press  under SELECT. |
| 4 | When the confirmation screen appears, press  under YES to delete all Call Alerts. |

Group Call

In a Group Call, you can communicate instantly with a group of people that you have previously set up as a Talkgroup. Group Calls go out to all members of the Talkgroup at the same time.

Your Nextel Sales Representative or Nextel Customer Care must set up your Talkgroups by providing you with a Talkgroup number for each Talkgroup. After you have the number, you can assign each Talkgroup number a name and store it in your phone (see “Storing a Talkgroup” on page 109). Your phone can store up to 30 Talkgroups. You can only make calls to Talkgroups for which you have been provisioned.

Storing a Talkgroup

| | |
|---|---|
| 1 | From the idle screen, press  . |
| 2 | Press  to scroll to Phonebook . |
| 3 | Press  under SELECT. |
| 4 | Press  to scroll to [New Entry] . |
| 5 | Press  under SELECT. The Entry Details screen displays. |
| 6 | Enter the information as you would any other Phonebook entry. (See “Adding Phonebook Entries” on page 45.) When you get to Type , make sure that you select Talkgroup . |
| 7 | Enter the Talkgroup number. For example: 127. |
| 8 | When you have completed the Entry Details , press  under DONE. |

Making a Group Call from the Keypad

| | |
|---|---|
| 1 | Press  and then enter the Talkgroup number of the group that you want to call. |
| 2 | Press and hold the PTT button on the side of the phone, wait for the chirp, and speak. The phones of individuals in the Talkgroup will emit a chirping sound to alert them that someone is calling. |
| 3 | Release the PTT button to listen. |

Making a Group Call from the Phonebook

- 1 From the **Phonebook** screen, press  to scroll to the name of the Talkgroup you want to call.
- 2 Press and hold the PTT button on the side of the phone, wait for the chirp, and speak. The phones of the people in the Talkgroup will emit a chirping sound to alert them that someone is calling.
- 3 Release the PTT button to listen.

Making a Group Call from the Recent Calls List

- 1 From the **Recent Calls** screen, press  to scroll to the name of the Talkgroup you want to call.
- 2 Press and hold the PTT button on the side of the phone, wait for the chirp, and speak. The phones of individuals in the Talkgroup will emit a chirping sound to alert them that someone is calling.
- 3 Release the PTT button to listen.

Receiving a Group Call

When you receive an incoming Group Call, your phone emits a chirp. The Talkgroup name or number displays on the screen.





To respond to a Group Call:

- 1 Wait for the caller to finish speaking.
- 2 Press and hold the PTT button. Begin talking after the phone emits a chirping sound. Release the PTT button to listen.

Joining a Group Call

Although you may be provisioned in more than one Talkgroup, you can only participate in one Group Call at a time. When you join a new Group Call, you no longer belong to your previous Group Call.









To join an ongoing Group Call:

- 1 Using the keypad, press  and then enter the Talkgroup number.
Or,
From the **Phonebook** screen, press  to scroll to the name of the Talkgroup you want to join.
Or,
If the Talkgroup you want to join is on your Recent Call list, go to the **Recent Calls** screen and press  to scroll to the name of the Talkgroup you want to join.
- 2 Press  under JOIN.

Group-Silent Programming

Group-Silent programming enables you to silence incoming Group Calls and communication.

Turning Group-Silent On or Off

- 1 From the idle screen, press .
- 2 Press  to scroll to **Settings**. Press  under SELECT.
- 3 Press  to scroll to **Tkgrp Settings**. Press  under SELECT.
- 4 With the **Silent** field highlighted, press  under CHANGE.
- 5 Press  to scroll to **On** or **Off**.
- 6 Press  under SELECT.

Datebook

The Datebook is a calendar in your *i80s* phone that enables you to schedule and organize events, such as appointments and meetings. Schedules can be created and viewed for specific days, and reminder alarms can be set so you never miss important events.

You can view upcoming events by week or by day. The Datebook stores and manages 250 events over a 13-month period (12 months ahead and 1 month back).

NOTE: The time and date format and the year used in Datebook can be set by you. Before using Datebook for the first time, ensure that the current year is correct. See “Initial Setup” on page 150 for more information.

This section includes:

| | |
|-----------------------------|----------|
| Datebook Icons | Page 114 |
| Viewing Your Datebook | Page 114 |
| About Datebook Events | Page 116 |
| Adding New Events | Page 117 |
| Editing Events | Page 121 |
| Deleting Events | Page 122 |
| Datebook Event Reminders | Page 122 |
| Customizing Datebook Set Up | Page 123 |



Datebook Icons

There are several icons commonly used in the Datebook application:

| Symbol | Description |
|--------|---|
| • | Event without a start/end time |
| > | More options are available |
| ↻ | Recurring Appointment |
| 🔔 | Datebook Alarm |
| → | Used to move through fields when setting a time and date. |

Viewing Your Datebook

To access your Datebook:

| | |
|---|--|
| 1 | From the idle screen, press  . |
| 2 | Press  to scroll to Datebook . |
| 3 | Press  under SELECT. |

Information in your Datebook can be viewed in three ways: by the week, the day, or the event.

This information is structured hierarchically. When you access the Datebook, it displays the current week. You can select a day to view and display the events of that day. When the events of a day are displayed, you can select an event to view and display details of that event.

Viewing a Week

When you access your Datebook, the current week is displayed. You can scroll to other weeks by pressing .

The dates of the displayed week appear at the top of the text area of your phone's screen.

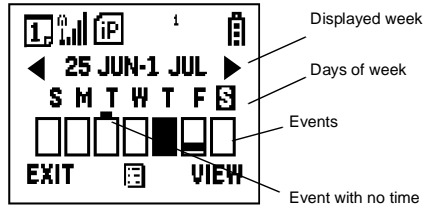



Below the dates are letters indicating the days of the week. When you access your Datebook, the current day is highlighted. You can scroll to other days by pressing .

Below each letter is a 12-hour time window for each day. Scheduled events are shown within the time window in black. Events scheduled outside the 12 hour time window will display in the day view but not in the week view.

A small bar on top of the time window indicates an event on that day that does not have a time of day associated with it, such as a birthday.

Viewing a Day



To view a day in your Datebook:

- 1 With a week displayed, select the day you want to view by pressing  until the letter for that day is highlighted.
- 2 Press  under VIEW.

The day and date appear at the top of the text display area. Events for the day selected are listed by time. Events without times are displayed at the top of the list with a bullet to the left of them.

Viewing Event Details



To view the details of an event:

| | |
|---|---|
| 1 | Select and view the day containing the event you want to view. |
| 2 | Press  to scroll to the event. |
| 3 | Press  under VIEW. |

This displays event details such as day of week, time, title, duration, alarm time, and repeat cycle. For more information about events, see “About Datebook Events” on page 116.

Viewing Today

You can easily go to the current day when viewing your Datebook:



| | |
|---|--|
| 1 | While viewing any week, day, or event, press  . This displays the Datebook Menu with Go to Today highlighted. |
| 2 | Press  under SELECT. |

About Datebook Events

Each Datebook event may contain the following information:

- The title you assign to the event. You can enter a title using the phone’s alphanumeric keypad or choose from a list of commonly used titles. A title is required for every event (maximum of 128 characters).
- Additional text following the event’s title.
- The start time and duration of the event.
- The date of the event.
- An option to repeat the event in your Datebook.
- An alarm to notify you of the event before it begins.
- The style you want your phone to use when the event occurs. See “Styles” on page 156 for more information.



Adding New Events

Using the following instructions, you will enter the information in the order the items appear on the **Event Form** screen. However, you can enter this information in any order by pressing  to scroll through the items on the **Event Form** screen. You can leave any item blank (except title and date) or unchanged by pressing  to scroll past it on the **Event Form** screen. Only a title and a date are required for a valid event.



To cancel a Datebook event entry at any time, press  to return to the idle screen.

To add a Datebook event:

- 1 Access the **Event Form** screen:

While viewing a week in the Datebook, press  to access the **Datebook Menu**. Press  to scroll to **New**. Press  under **SELECT**.

Or,

While viewing a day, press  to scroll to **[New Event]**. Press  under **SELECT**.

The **Event Form** screen displays with the **Title** field highlighted.

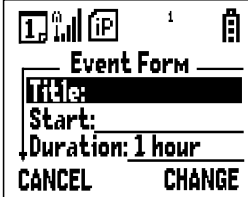

- 2 With the **Title** field highlighted, press  under **CHANGE** to access the **Title** screen.

3 Assign a title to the event:

Press under **BROWSE** to choose from a list of commonly used event titles. Press to scroll to the title you want and press under **SELECT**.

Or,

Type the title using the alphanumeric keypad. See “T9 Text Input Entry Modes” on page 24 for information about entering text into this field.

You can also enter a description of the appointment or any other text.

When you are finished, press under **OK**.

The **Event Form** screen returns with the **Start** field highlighted.

4 If you want to assign a time of day to the event:

With the **Start** field highlighted, press under **CHANGE**.

From the **Start** screen, enter the time the event will begin.

Type in the start time, or press to scroll through the hours, minutes, and am, pm, or 24 hour clock. Press or press under **→** to move through the fields.

Press under **DONE**.

The **Event Form** screen returns with the **Duration** field highlighted.

- 5** After you have assigned a start time to the event, you can specify the duration of the event. The default duration is one hour. To assign a different duration:

With the **Duration** field highlighted, press  under CHANGE.

From the **Duration** screen, press  to scroll to the desired duration. If you select **None**, the event will have a duration of zero minutes.



Press  under SELECT.

The **Event Form** screen returns with the **StartDate** field highlighted.

- 6** The default date assigned to an event is the day that was highlighted when you accessed the **Event Form** screen to add the event. To assign a different date:

With the **StartDate** field highlighted, press  under CHANGE.

From the **StartDate** screen, enter the date of the event:

Type in the date, or press  to scroll through the months, days, and years. Press  or press  under → to move through the fields.

Press  under DONE.

The **Event Form** screen returns with the **Repeat** field highlighted.

- 7 If you want the event to recur in your Datebook, assign a repeat cycle to it:



With the **Repeat** field highlighted, press  under CHANGE.

From the **Repeat** screen, press  to scroll to the desired repeat cycle.

Press  under SELECT.

The **Event Form** screen returns with the **RepeatEnd** field highlighted.

NOTE: When Repeat is set to none or yearly, it will not be possible to access the Repeat End field.

Press  under CHANGE and enter the date on which you want the event to stop repeating. When you have finished, press  under DONE.

The **Event Form** screen returns with the **Alarm** field highlighted.

- 8 If you want to set an alarm to remind you that the event is approaching:

With the **Alarm** field highlighted, press  under CHANGE.

From the **Alarm** screen, press  to scroll to the desired alarm option (5 minutes before, 1 hour before, etc.).

Press  under SELECT.



- 9 If you want your phone to change to a style you have defined when the event occurs (see “Styles” on page 156):

With **MORE** highlighted, press  under SELECT. The **Style** field appears.

Press  under CHANGE.

From the **Style** screen, you see a list of styles you have created. Press  to scroll to the desired style.

Press  under SELECT.

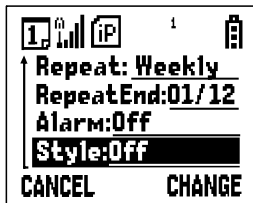

- 10 When you have entered all the desired information about the event, press  under DONE.







Editing Events

- 1 If you are viewing the event:

Press  under EDIT.

Or,

If you are viewing the day containing the event:

Press  to scroll to the event you want to edit. Press  to display the **Datebook Menu**. Press  to scroll to **Edit** and then press  under SELECT.

- 2 Follow the applicable instructions in “Adding New Events” on page 117 to edit the various fields.

Deleting Events

- 1 View the day containing the event and press  to scroll to the event you want to delete.

Or,

View the details of the event you want to delete.

- 2 Press . The **Datebook Menu** displays.

- 3 Press  to scroll to **Delete** and press  under SELECT.

- 4 If the event is a recurring event, the **Delete Event** screen appears:

- To delete only the occurrence of the event you select in step 1, leave **This Event Only** highlighted.
- To delete all occurrences of the event, press  to highlight **Repeat Events**.

Press  under SELECT.

- 5 If the event is a recurring event, a confirmation screen appears. Press  under YES to confirm.

Datebook Event Reminders

If you have set an alarm to remind you that a Datebook event is approaching, your phone sounds an audible alarm and displays a reminder.

NOTE: You must have the Time and Date display turned on to receive event reminders. This is the default setting.

Press  under VIEW to view more information about the Datebook event.

Or,

Press  under EXIT to dismiss the event reminder.





Customizing Datebook Set Up

Datebook allows you to customize some of its set up features:

- **DailyBegin** — sets the beginning time of the 12-hour day your Datebook displays when you are viewing a week. The default is 7:00 am.
- **Reminder** — controls the behavior of alarms you have set in Datebook:
 - **Active Only** sets Datebook to ignore alarms that occur when your phone is powered off. This is the default setting.
 - **Delayed If Off** sets Datebook to delay alarms that occur when your phone is powered off until your phone is next powered on.
- **Weekday** — sets the first day of the week your Datebook displays when you are viewing a week. The default is Sunday.
- **DeleteAfter** — controls how long your Datebook waits to delete an event after it has occurred. The default is four weeks.

To customize your Datebook set up:

1 While viewing a week in the Datebook, press  to access the **Datebook Menu**.

2 Press  to scroll to **Setup** and then press  under SELECT.

3 Press  to scroll to any of the set-up features.

Press  under CHANGE.

Use the screens that appear to make your changes.

Memo





The Memo application provides you with a place to store a numeric note (for example, a phone number) in your *i80s* phone that you can call.

This section includes:

| | |
|-------------------|----------|
| Adding a New Memo | Page 125 |
| Viewing a Memo | Page 125 |
| Editing a Memo | Page 126 |
| Deleting a Memo | Page 126 |



Adding a New Memo

You can add a memo from the idle screen or while on an active call.

| | |
|---|--|
| 1 | Press  . |
| 2 | Press  to scroll to Memo . |
| 3 | Press  under SELECT. The Memo screen displays. |
| 4 | Type your numeric memo using the phone's keypad. |
| 5 | Press  under STORE. |

NOTE: Only one memo can be stored.

Viewing a Memo

| | |
|---|--|
| 1 | From the idle screen, press  . |
| 2 | Press  to scroll to Memo . |

3 Press  under SELECT.

4 To call this number, press .

Editing a Memo

1 From the idle screen, press .

2 Press  to scroll to **Memo**.

3 Press  under SELECT.

4 Type the new number.

You can delete a digit by pressing  under DELETE. To delete all the digits, press and hold  under DELETE.

5 Press  under STORE.

Deleting a Memo

1 From the idle screen, press .

2 Press  to scroll to **Memo**.

3 Press  under SELECT.

4 Press and hold  under DELETE.

5 Press  under STORE.

Voice Notes

The Voice Notes feature enables you to record and play back personal messages or the incoming portion of phone calls on your *i80s* phone.

This section includes:

| | |
|--------------------------------|----------|
| About Voice Notes | Page 127 |
| Accessing Voice Notes | Page 128 |
| Recording a Voice Note | Page 128 |
| Playing a Voice Note | Page 129 |
| Adding to a Voice Note | Page 129 |
| Labeling a Voice Note | Page 129 |
| Deleting Voice Notes | Page 130 |
| Locking/Unlocking a Voice Note | Page 131 |
| Voice Notes Memory | Page 131 |



About Voice Notes

Your phone can store up to 20 Voice Notes, with a maximum total time of approximately three minutes, depending on available memory. Voice Notes are automatically labeled with the time and date they were recorded.

IMPORTANT LEGAL NOTE: Voice Notes recording capabilities should only be used in accordance with applicable state laws. Please check your local laws regarding the recording of conversations using the Voice Notes feature.



Accessing Voice Notes

To access the Voice Notes feature:





- | | |
|---|--|
| 1 | From the idle screen, press  . |
| 2 | Press  to scroll to VoiceNotes . |
| 3 | Press  under SELECT. |

Recording a Voice Note



To record a personal message as a Voice Note:

- | | |
|---|--|
| 1 | From the VoiceNotes screen, press  to scroll to [New VoiceNote] . |
| 2 | Press  under RECORD and speak the message you want to record into the microphone. |
| 3 | When you are finished recording your Voice Note, press  under STOP. |

To record the incoming portion of a call as a Voice Note:

- | | |
|---|--|
| 1 | While on an active call, press  . |
| 2 | Press  to scroll to Record . |
| 3 | Press  under SELECT to record the incoming portion of the call. Your own voice will not be recorded. |
| 4 | When you are finished recording your Voice Note, press  under STOP. |





Playing a Voice Note

- 1 From the **VoiceNotes** screen, press  to scroll to the Voice Note you want to play.
- 2 Press  under **PLAY**.
- 3 To stop the Voice Note while it is playing, press  under **BACK**.

NOTE: Voice Notes are heard through the speaker.

Adding to a Voice Note





After you create a Voice Note, you can go back and record additional information at the end of the existing Voice Note:

- 1 From the **VoiceNotes** screen, press  to scroll to the Voice Note you want to add to.
- 2 Press  to view the **VoiceNotes Menu**.
- 3 Press  to scroll to **Add To**.
- 4 Press  under **SELECT** and speak the message you want to record into the microphone.
- 5 When you are finished recording, press  under **STOP**.

Labeling a Voice Note





When you create a Voice Note, it is labeled with the time and date it was recorded. After a Voice Note has been recorded, you can re-name it with a custom label.

To label a Voice Note:





| | |
|---|---|
| 1 | From the VoiceNotes screen, press  to scroll to Voice Note you want to name. |
| 2 | Press  to view the VoiceNotes Menu . |
| 3 | Press  to scroll to Label and press  under SELECT. |
| 4 | At the Enter Label screen, enter a label for the Voice Note using the alphanumeric keypad. |
| 5 | Press  under OK. |

Deleting Voice Notes

To delete a Voice Note:

| | |
|---|--|
| 1 | From the VoiceNotes screen, press  to scroll to the Voice Note you want to delete. |
| 2 | Press  to view the VoiceNotes Menu . |
| 3 | Press  to scroll to Delete and press  under SELECT. |
| 4 | A confirmation screen appears. Press  under YES to confirm. |





To delete all unlocked Voice Notes:

| | |
|---|--|
| 1 | From the VoiceNotes screen, press  to view the VoiceNotes Menu . |
| 2 | Press  to scroll to Delete All and press  under SELECT. |
| 3 | A confirmation screen appears. Press  under YES to confirm. |

Locking/Unlocking a Voice Note





Locking a Voice Note prevents it from being deleted. When a Voice Note is locked, the locked icon  appears next to it.

To lock or unlock a Voice Note:

- | | |
|---|--|
| 1 | From the VoiceNotes screen, press  to scroll to the Voice Note you want to lock or unlock. |
| 2 | Press  to view the VoiceNotes Menu . |
| 3 | Press  to scroll to Lock or Unlock . |
| 4 | Press  under SELECT. A confirmation screen displays. |

Voice Notes Memory

Typically, you can store up to 20 Voice Notes with a total time of about three minutes. To check the amount of memory available for Voice Notes:

- | | |
|---|---|
| 1 | From the VoiceNotes screen, press  to view the VoiceNotes Menu . |
| 2 | Press  to scroll to Memory . |
| 3 | Press  under SELECT to display the Memory Meter screen. The memory meter shows the amount of Voice Notes memory space currently in use. It fills in from left to right as your Voice Notes memory space fills up. |
| 4 | From the Memory Meter screen, you can free more Voice Notes memory space by pressing  under DELETE to delete all unlocked Voice Notes. A confirmation screen displays. Press  under YES to confirm. |

NOTE: Voice Notes and Java application data share the same memory space on your phone. Using a large amount of memory to store Java application data reduces the space available for Voice Notes. You can create more memory space to store Voice Notes by deinstalling stored Java applications. See “Deinstalling Java Apps” on page 139.

Nextel Wireless Web

You can use your phone's Net feature to access a suite of wireless data products known as Nextel Wireless Web services. You can use your Nextel Internet-ready phone to send and receive email, obtain driving directions, check weather and news updates, view the latest stock quotes, conduct financial transactions, and more. Access the specific information you need to get business done... easily... wirelessly!

Nextel Wireless Web* requires the activation of a Nextel OnlineSM Service Plan. Nextel Online Service Plans vary in product and service offerings. Select services are only available with the Nextel Online Plus Service Plan.

To order, contact Nextel Customer Care.

For more information, see the *Nextel Wireless Web User's Guide*.

* *Nextel Wireless Web is only available in the continental United States.*

This section includes:



| | |
|------------------------------|----------|
| Wireless Web Navigation Keys | Page 133 |
| Starting the Microbrowser | Page 134 |
| Using Your Phone as a Modem | Page 135 |

Wireless Web Navigation Keys

You can navigate within the phone's microbrowser by using the following keys:

Home: Press  to return to your home page.

Back: Press  to return to a previous screen.

Scroll: Arrows on the left of your phone's display screen () indicate that additional text can be viewed. Press  to scroll one line at a time, or press and hold to scroll one page at a time.

Starting the Microbrowser

Just as you use Netscape Navigator® or Microsoft® Internet Explorer to browse the Web from your desktop, the microbrowser contained in your phone allows you to explore and use a variety of Internet services. To begin using the Nextel Wireless Web:

1 From the idle screen, press  to access the **Main Menu**.

2 Press  to scroll to **Net**.

3 Press  under SELECT.



4 Your home page displays.

NOTE: The first time you access Net, you will be asked to enable security to ensure your information remains private and secure. Press  under Yes. The phone will display: Generating..., Computing..., Sending))))).

You may be asked to (re)enable security as Nextel adds new services or upon your return to the U.S. after traveling.

When transmitting highly personal or sensitive data, such as a credit card number, you will see the Secure Data icon . This icon indicates that the data is encrypted during transmission.



- 5 Scroll to highlight the service you wish to access and press  under OK, or press the number shown to the left of your desired selection to automatically jump to that service.

Press  to return to the previous screen. To return to the home page from anywhere within the various menus and sub-menus, press .

NOTE: Home pages will vary depending on the Nextel Online Service Plan to which you have subscribed.

- 6 To exit the browser, press  until the idle screen displays.

Or,

Press and hold . The **Browser Menu** screen displays with **Exit Browser** highlighted. Press  under OK. When you re-enter **Net**, you will enter on the page from which you exited.

Using Your Phone as a Modem

With Nextel OnlineSM Dial-Up Service, you can use your *i80s* phone as a wireless modem! You can connect your IBMTM-compatible computer* or Personal Digital Assistant* (PDA) to your *i80s* phone and access your company's network or the Internet — all without the hassle of locating a telephone jack for a landline connection.

* Visit nextel.com for compatible operating systems.

To use Nextel Online Dial-Up Service, you must subscribe to a Nextel Online Service Plan and have Dial-Up Service activated. To activate this service, contact Nextel Customer Care.

NOTE: Nextel Online Dial-Up Service is only available in the continental United States and Hawaii.

Java Apps

The Java Apps feature of your *i80s* phone runs programs, or applications, written in the Java programming language. Some Java applications are pre-loaded on your *i80s* phone.



You can download, install, and run additional Java applications by loading them into your phone via the Internet at nextel.com or directly from your *i80s* phone.

This section includes:

| | |
|---------------------------------|----------|
| Accessing Java Apps | Page 137 |
| Installing Java Apps | Page 138 |
| Running Java Apps | Page 138 |
| Downloading Custom Applications | Page 139 |
| Deinstalling Java Apps | Page 139 |
| Java Apps Memory | Page 140 |

Accessing Java Apps

To access the Java Apps applications:

- 1 From the idle screen, press .
- 2 Press  to scroll to **Java Apps**.
- 3 Press  under SELECT.

The **Java Apps** screen displays all your stored Java applications.

Installing Java Apps

To install Java applications on your phone:

- 1 From the **Java Apps** screen, press  to scroll to the desired application.
- 2 To determine whether the application needs to be installed, look at the display options on the screen.



If the display option is RUN or SELECT, the application is already installed and ready to run. See “Running Java Apps” on page 138.

If the display option is INSTALL, press  under INSTALL to install the application.
- 3 The screen will display a series of installation steps. A checkmark will appear as each step is completed. This may take several minutes.

When your phone has finished installing the application, press  under DONE.

Running Java Apps

To run an application:

- 1 From the **Java Apps** screen, press  to scroll to the application you want to run.
- 2 Press  under RUN or SELECT.

NOTE: If you receive an incoming phone call, the Java application will be suspended.



To suspend a running application:

Press .

To resume a suspended application:

Press  under RESUME.

To stop a running application:

Press  and then press  under EXIT.

Downloading Custom Applications





You can customize your phone by downloading additional Java applications. You can connect your phone to a PC using the data cable and download applications via nextel.com, or you can use the DownloadApps application on your phone. DownloadApps allows you to download Java applications over-the-air without a data cable. Go to nextel.com for the selection of applications and downloading instructions.

To install additional Java applications, your phone must have enough memory. See “Java Apps Memory” on page 140 for information on how to check available memory. If you do not have enough memory to install additional Java applications, see “Deinstalling Java Apps” on page 139 for information on how to free additional memory.

NOTE: You must subscribe to Nextel Wireless Web services in order to download applications over-the-air using DownloadApps.

Deinstalling Java Apps

To remove Java applications from your phone:

- 1 From the **Java Apps** screen, press  to scroll to the application you want to remove.
- 2 Press .
- 3 Press  to scroll to **DEINSTALL**.
- 4 Press  under SELECT.

5 A confirmation screen displays. Press under YES.

6 When your phone has finished deinstalling the application, press under DONE.

Java Apps Memory

If you want to install custom Java applications in your phone, you must have enough memory in your phone to store and run the custom application you want. If you do not have enough memory, you can deinstall an application or delete a Voice Note (see “Deleting Voice Notes” on page 130) to free up memory.

You can check to see how much **Data**, **Program**, and **Heap** memory your phone has free:

- **Data** refers to the memory used to store application data, such as image files. Data memory determines memory space available to download additional Java applications.
- **Program** refers to the memory used to install applications.
- **Heap** refers to the Random Access Memory (RAM) available to run a Java application.

To check how much memory your phone has available for Java applications:

1 From the **Java Apps** screen, press to scroll to **Java System**.

2 Press under SELECT.

3 Press under NEXT.

4 To see more memory information, press under NEXT again.

NOTE: Java application data and Voice Notes share the same memory space on your phone. Using a large amount of memory to store Voice Notes reduces the space available for Java application data. You can create more memory space to download Java applications by deleting stored Voice Notes. See “Deleting Voice Notes” on page 130.

Customizing the i80s Phone

You can customize your i80s phone to fit the way you want to use it.



This section includes:

| | |
|-----------|----------|
| Settings | Page 141 |
| Styles | Page 156 |
| Shortcuts | Page 161 |

Settings

The phone's Settings menu enables you to control many of the phone's features and functions, including display properties, message handling, and security features.

To access the Settings menu:



| | |
|---|--|
| 1 | From the idle screen, press  . |
| 2 | Press  to scroll to Settings . |
| 3 | Press  under SELECT. |



From the **Settings** screen, you can access these Settings options:

- **Ring/Vibe** — controls how your phone rings or vibrates when you receive calls and messages.
- **Phone Setup** — sets call-answering features, chooses which phone line is used, and sets your network ID.
- **In Call Setup** — sets call timer, message notification, and call waiting features.
- **Security** — sets security features including phone lock, keypad lock, and SIM PIN.
- **Personalize** — controls which features are most accessible when you turn on your phone.

- **Initial Setup** — sets a variety of display features including the language displayed, the screen contrast, time and date formats, current year, backlight, status light, and scrolling. Also turns auto redial on or off and sets baud rate.
- **VoiceVolume** — sets the volume of your phone's earpiece and speaker.
- **Tkgrp Settings** — sets certain Talkgroup options.
- **Service Status** — shows the status of your phone's services.

To access any of these options:

- | |
|---|
| <p>1 From the Settings screen, press  to scroll to the option you want to access.</p> |
| <p>2 Press  under SELECT.</p> |

Many of these options have other options within them. Press  to scroll through the lists of options, and press  to select and modify options and the features, according to the instructions on your phone's screen. For some options, you can also press  to select sub-options.

In screens that show lists of options for a setting, a check mark to the left of the option indicates the current option for the setting.

Ring/Vibe

Ring/Vibe enables you to control how your phone rings and vibrates when you receive calls and messages. You can set ring volume, choose ring styles, and use the VibraCall[®] Alert feature which enables you to set your phone to alert you to calls and messages by vibrating.

Main Options

Ring/Vibe provides these main options:

- **Ringer Vol** — sets ring volume.
- **Keypad Vol** — sets volume of sounds associated with keypad actions.
- **Mail Vol** — sets volume of Text Message, Voice Mail, and Net Mail notifications.
- **Java/Data Vol** — sets data or Java application volume.

- **Headset** — choosing the **HdsetOnly** option prevents sound from being emitted from the phone's speaker when the headset is being used.
- **VibeAll** — choosing **On** sets the phone to vibrate for all calls, messages, and alerts; choosing **Off** enables you set the type of notification for each of these features.





Ring Style and Notification Type

When you set **VibeAll** to **On**, your phone vibrates to notify you of all types of calls, messages, and alerts.





When you set **VibeAll** to **Off**, the following features display after **VibeAll** on the **Ring/Vibrate** screen, enabling you to set notification options for each:

- **Line 1** — sets the ring style and type of notification for calls on Line 1.
- **Line 2** — sets the ring style and type of notification for calls on Line 2.
- **Pvt/Grp** — sets type of notification for Private and Group Calls.
- **Call Alert** — sets the ring style and type of notification for Call Alerts.
- **Text Msgs** — sets type of notification for Text Messages.
- **Reminders** — sets type of notification for Datebook reminder alarms.
- **Voicemail** — sets type of notification for Voice Mail messages.
- **Netmail** — sets type of notification for Net Mail messages.

To set **VibeAll** to **Off** or **On**:

| | |
|---|--|
| 1 | From the Ring/Vibrate screen, press  to scroll to VibeAll . |
| 2 | Press  under CHANGE. |
| 3 | Press  to scroll to Off or On . |
| 4 | Press  under SELECT. |





The following icons appear on your display screen to indicate the options you have chosen:

| Icon | Indicates... |
|---|--|
|  | Vibrate All - phone is set to vibrate when you receive all types of calls, messages, and alerts; the VibeAll option is On . |
|  | Vibrate On - phone is set to vibrate when you receive phone calls. |
|  | Vibrate Then Ring - phone is set to vibrate and then ring when you receive phone calls. |
|  | Silent - phone is set not to ring. |

Ring Styles

When you set a ring style, you can choose from any of nine pre-set ring styles.

To set a ring style:

- 1 From the **Ring/Vibrate** screen, ensure that **VibeAll** is set to **Off**. Then press  to scroll to any of the features that allow you to set a ringer style: **Line 1**, **Line 2**, or **Call Alert**.
- 2 Press  under SELECT.
- 3 With the **Style** field highlighted, press  under CHANGE.
- 4 Press  to scroll to the ring style you want to assign to the feature.
- 5 To assign the ring style, press  under SELECT.





USER TIP: To hear the ring style you have selected, press the volume control buttons on the side of your phone.

Notification Types

When you set a notification type, you have these options:

- **Ring** — the phone rings to notify you.
- **Vibe** — the phone vibrates to notify you.
- **Vibe/Ring** — the phone vibrates and then rings to notify you. This option is only available for calls on Line 1 and Line 2.
- **Silent** — the phone does not ring to notify you.

To set a notification type:

| | |
|---|---|
| 1 | From the Ring/Vibrate screen, ensure that VibeAll is set to Off . Then press  to scroll to any of the features on the Ring/Vibrate screen after VibeAll . |
| 2 | Press  under SELECT. |
| 3 | With the Type field highlighted, press  under CHANGE. |
| 4 | Press  to scroll to the notification type you want to assign to the feature. |
| 5 | To assign the notification type, press  under SELECT. |

Phone Setup

Phone Setup sets some basic phone features. Access Phone Setup to set the following options:

- **Line** — enables you to choose Line 1 or Line 2 as the active line for outgoing calls.
- **AutoAns** — sets your phone to automatically answer an incoming call after a specified number of rings. When this feature is turned on, the phone answers by connecting you to the caller; it does not send the call to Voice Mail, unless you are out of coverage or on another call.
- **Any Key** — when turned on, enables you to answer calls by pressing any key on the alphanumeric keypad.
- **Network ID** — sets the phone's network IDs. Use only under the direction of a Nextel Customer Care Representative.

In Call Setup

In Call Setup sets the in-call timer, message notification, and call waiting features.

- The **In Call Timer** option turns the following features on and off:
 - **Display** — the duration of each call displays on the phone's screen.
 - **Minute Beep** — an audible beep occurs every minute of an active call at the 50 second mark.
- The **Notifications** option controls message notification during calls:
 - **Receive All** — notifies you of all types of messages during calls.
 - **Msg Mail Only** — notifies you of mail messages only; all other types of message notifications are delayed until the call has ended.
 - **Delay All** — delays notification of all messages until the call has ended.
- **Call Waiting** — enables you to turn off call waiting for the next call. After you end the call, call waiting is turned back on.

Security

Security allows you to set security features:

- **Phone Lock** — sets an optional code that locks your phone.
- **Keypad Lock** — displays instructions for locking and unlocking your phone's keypad.
- **SIM PIN** — enables and disables your phone's SIM PIN security feature.
- **New Passwords** — enables you to change your phone's unlock code, security code, and SIM PIN.
- **Master Reset** — allows Nextel Customer Care to reset your service in the event of a provisioning problem.

Using Phone Lock

The Phone Lock feature enables you to prevent your phone from being used unless an Unlock code is typed into the keypad.

The Unlock code is required to enable the phone lock feature, to unlock the phone, and to set a new Unlock code. Your default Unlock code is 0000.

Phone lock provides two options for locking the phone:

- **Lock Now** locks the phone immediately after you set the option.
- **Auto Lock** locks the phone the next time the phone is powered on.

Setting Keypad Lock

Choosing the Keypad Lock option displays instructions for locking and unlocking your phone's keypad. See "Keypad Lock" on page 20 for more information on locking the keypad.

Enabling and Disabling SIM PIN

The SIM PIN option enables and disables the feature that requires a SIM PIN code to be typed into the phone to access the information on the SIM card and to make or receive calls. See "SIM Card Personal Identification Number (PIN)" on page 13 for more information.

Setting New Passwords

The New Passwords option enables you to set three types of passwords that control access to your phone:

- **Unlock Code** — this code is used to control access to the phone using Phone Lock. It is also required to access the Master Clear and Feature Reset features. If you want to use any of these features, contact Nextel Customer Care for your default Unlock code.
- **Security Code** — this code is used to access the Master Reset feature under the direction of a Nextel Customer Care Representative. It can also be used to override your Unlock code under the direction of a Nextel Customer Care Representative.
- **SIM PIN** — this code is used to access the information on your SIM card and to make or receive calls. When you get your phone, your SIM PIN is 0000. You should change this to a SIM PIN known only to you as soon as you get your phone. For information on changing your SIM PIN, see "Changing the PIN" on page 16.

Using Master Reset







The Master Reset option is provided for use only under the direction of a Nextel Customer Care Representative. It resets your service.

Personalize

Personalize contains three options that control which major features are easiest to access when you turn on your phone:

- **Main Menu** — changes the order of the items on your main menu.
- **Keys** — controls which main menu items appear above the two option keys on the idle screen.
- **Power Up App** — sets any of the programs on the main menu to run when you turn on your phone.







Reordering Main Menu

| | |
|---|--|
| 1 | From the Personalize screen with Main Menu highlighted, press  under SELECT to access the Reorder Menu screen. |
| 2 | Press  to scroll to the main menu option you want to move. |
| 3 | Press  under GRAB. |
| 4 | Press  to move the option up or down in the list. |
| 5 | When the item is where you would like it to appear in the main menu, press  under INSERT. |
| 6 | Repeat step 2 through step 5 for all main menu items you want to move. |
| 7 | Press  under DONE. |

Changing Idle Screen Options





Two options from the main menu always appear on your idle screen above the left and right option keys. Each option can be accessed by pressing the corresponding option key.

Your phone arrives with Phonebook (PHBK) assigned to the left option key and Messages (MESG) assigned to the right option key. You can assign any main menu option you want to the option keys.

| | |
|---|---|
| 1 | From the Personalize screen, press  to scroll to Keys . |
| 2 | Press  under SELECT. The Keys screen shows the option assigned to each option key (Left and Right). |
| 3 | To change the option assigned to the left option key, press  under CHANGE while Left is highlighted. |
| 4 | Press  to scroll to the option you want to assign to the left option key. |
| 5 | Press  under SELECT. |
| 6 | To change the option assigned to the right option key, press  to highlight Right and press  under CHANGE. Repeat steps 4 and 5 for the right option key. |

Changing Power-Up Application

Your phone is set to display the idle screen when it is powered on. You can set the phone to display the main screen of any main menu option when it is powered on.

| | |
|---|--|
| 1 | From the Personalize screen, press  to scroll to Power Up App . |
| 2 | Press  under SELECT. The Power Up App screen shows the name of the program or screen that currently appears when the phone is powered on. |
| 3 | Press  under CHANGE. |
| 4 | Press  to scroll to the option you want to appear when the phone is powered on. |
| 5 | Press  under SELECT. |

Initial Setup

Initial Setup enables you to control a variety of your phone's features that you may want to modify when you first get your phone:

- **Time/Date Format** — sets the format in which the time and date display on your phone.
- **Year** — sets the current year.

NOTE: Changing the current year may affect stored Datebook events. Datebook stores events 12 months ahead and one month before the current date. Events outside this range will be deleted. See "Datebook" on page 113 for more information.

- **Auto Redial** — turns the automatic redial feature on and off.
- **Backlight** — controls how long your phone's backlight stays on.
- **Status Light** — controls whether the status light is on when the phone is on.
- **Contrast** — sets the display contrast lighter or darker.
- **Scroll** — sets how you can scroll lists and menus.
- **Language** — sets the language that your phone displays.
- **Master Clear** — returns all phone's settings to their original factory defaults and erases all stored lists. Use only under the direction of a Nextel Customer Care Representative.
- **Feature Reset** — returns all settings to their original defaults. Use only under the direction of a Nextel Customer Care Representative.
- **Baud Rate** — sets the baud rate at which your phone communicates when connected to a laptop computer, PC, or similar device.
- **TTY Setup** — sets TTY options. By default, your phone is set to function with a TTY device.
- **TTY Baud Rate** — sets the baud rate at which your phone communicates when connected to a TTY device.

Changing Time and Date Format

Your phone displays times in 12-hour-clock format (12:00 am through 11:59 pm) or 24-hour-clock format (0:00 through 23:59). It displays dates in month/day format or day/month format.

NOTE: If you turn the time and date display off, no times are associated with calls on your Recent Calls list, and the alarm feature of your Datebook is disabled.

To set the time and date format, or turn time and date display on or off:

1 From the **Initial Setup** screen with **Time/Date Format** highlighted, press  under SELECT to access the **Time/Date Format** screen.



2 To change the time format:

With **Time Format** highlighted, press  under CHANGE to access the **Time Format** screen.

Press  to highlight the time format you want.

Press  under SELECT.



3 To change the date format:

Press  to highlight **Date Format**, and press  under CHANGE to access the **Date Format** screen.

Press  to highlight the date format you want.

Press  under SELECT.

4 To turn the time and date format on or off:

Press  to highlight **Display**, and press  under CHANGE to access the **Display** screen.

Press  to choose **Off** or **On**.

Press  under SELECT.

Setting Auto Redial





When Auto Redial is set to **On**, if you receive a **System Busy, Try Later** message while making a call, the phone will redial the number automatically. You will hear a ring-back tone when a successful call is placed.

When Auto Redial is set to **Off**, you must press and hold  to redial the last number dialed.

Setting Backlight Timer

The backlight illuminates the display when you receive or make calls or use the phone in poor lighting conditions. You can set the amount of time that the backlight stays on to 5, 10, 20, or 30 seconds, or set it to stay on continuously or stay off at all times.

NOTE: The photosensor judges the lighting conditions and will activate the backlight only when your phone is in poor lighting conditions.

| | |
|---|---|
| 1 | From the Initial Setup screen, press  to scroll to Backlight . |
| 2 | Press  under CHANGE. |
| 3 | Press  to scroll to the desired backlight option. |
| 4 | Press  under SELECT. |

NOTE: Setting the backlight to stay on continuously will decrease the amount of time you can use the phone before recharging the battery.

Adjusting Status Light

The status light is located on the top of the phone. It illuminates when the phone is on. See “Status of Your i80s Phone” on page 23. You can turn the status light feature on or off from the **Initial Setup** screen.

Setting Contrast

You can set the contrast of your phone’s display to be lighter or darker. Use  to increase or decrease the contrast.

Setting Scrolling

You can set your phone to scroll through menus and lists in either of two ways:

- **Up/Down** — when you reach the bottom or top of a list or menu, scrolling stops until you scroll in the other direction.





- **Wrap Around** — when you reach the bottom or top of a list or menu scrolling “wraps” around and continues at the other end of the list or menu. This is the default setting.

You can set the scrolling style from the **Initial Setup** screen using the **Scroll** option.

Changing Display Language

You can customize the i80s Phone to display menus in English, French, Spanish, or Portuguese. The default language is English.

To change the display language:

| | |
|---|--|
| 1 | From the Initial Setup screen, press  to scroll to Language . |
| 2 | Press  under CHANGE. |
| 3 | Press  to scroll to the language you want your phone to display. |
| 4 | Press  under SELECT. |

Master Clear

Master Clear returns all your phone’s settings to their original factory defaults and erases all stored lists. Use only under the direction of a Nextel Customer Care Representative.

Feature Reset

Feature Reset returns all your phone’s settings to their original defaults. Use only under the direction of a Nextel Customer Care Representative.

Setting Baud Rate

You can set your phone’s baud rate from the **Initial Setup** screen. Scroll to the **Baud Rate** option and then choose the baud rate you want, or choose **Auto** to set your phone to automatically choose the appropriate baud rate.

Setting TTY Mode





TTY Setup enables you to set your options for using your phone with a teletypewriter (TTY) device. By default, your phone is set to function with a TTY device in TTY mode.

Your phone supports the following TTY modes:

- **TTY** — for calls in which you type and read text on your TTY device.
- **VCO** (Voice-Carry-Over) — for calls in which you speak into your phone and read text replies on your TTY device.
- **HCO** (Hearing-Carry-Over) — for calls in which you type text on your TTY device on listen to voice replies on your phone's speaker.

You can set your TTY mode using your phone's **Settings** menu at any time, or by issuing commands from your TTY device while on an active call.

To set your phone's TTY mode using your phone's **Settings** menu:

| | |
|---|---|
| 1 | From the Initial Setup screen, press  to scroll to TTY Setup . |
| 2 | Press  under CHANGE. |
| 3 | Press  to scroll to the desired TTY mode; Off , TTY , VCO , or HCO . |
| 4 | Press  under SELECT. |

To set your phone's TTY mode from your TTY device, issue one of the following commands while on an active call:

- "VCO please" — to select VCO mode.
- "HCO please" — to select HCO mode.
- "HCO off please" — to turn off HCO mode.





| | |
|---|--|
|  <p>WARNING</p> | <p>When you are using HCO, the sound coming from your phone speaker may be uncomfortably loud. Use caution when putting the phone to your ear. (For information on setting your phone's speaker volume, see "VoiceVolume" on page 155.)</p> |
|---|--|

NOTE: TTY device manufacturer's proprietary feature such as Turbo-Code, High-Speed, and Interruption are not supported by your phone. These features must be turned off or disabled to use your TTY device with your phone.

Setting TTY Baud Rate





By default, your phone's TTY baud rate is set to 45.45, the baud rate required for TTY calls within the US. To make calls outside the US, set your TTY baud rate to 50.0.

To change the TTY baud rate:

| | |
|---|--|
| 1 | From the Initial Setup screen, press  to scroll to TTY Baud . |
| 2 | Press  under CHANGE. |
| 3 | Press  to scroll to the baud rate for your location. |
| 4 | Press  under SELECT. |

VoiceVolume

VoiceVolume sets the volume of the sound coming from your phone's earpiece or speaker:

| | |
|---|---|
| 1 | From the VoiceVolume screen, highlight Earpiece Vol to set the earpiece volume, or press  to scroll to Speaker Vol to set the speaker volume. |
| 2 | Press  under CHANGE. |
| 3 | To select a volume level: Press  to raise or lower the volume setting. Or, Press the volume control buttons on the side of your phone. |
| 4 | Press  under OK. |

Tkgrp (Talkgroup) Settings

Tkgrp Settings enables you to set certain Talkgroup options. See “Group Call” on page 108 for more information.

Service Status

The Service Status screen shows the status of your Nextel services. This screen is for information only; no options can be set.

Styles

The Styles feature enables you to save a group of settings for call and message notification, screen display, and call answering features. You save your selections as a “style” and access them at any time.

Your phone comes with pre-set styles, such as Car and Meeting. You can use these pre-set styles, edit them or create your own styles. You can have up to ten total styles.

Each style contains the following settings:

- **Ring/Vibe** — controls how your phone rings and vibrates when you receive calls and other messages. See “Ring/Vibe” on page 142.
- **Backlight** — controls how long your phone’s backlight stays on. See “Setting Backlight Timer” on page 152.
- **Call Filter** — enables you to set your phone to not ring or vibrate when you receive some or all calls, messages, and alerts. See “Setting Call Filtering” on page 159.
- **Auto Answer** — sets your phone to automatically answer an incoming call after a specified number of rings. When this feature is turned on, the phone answers by connecting you to the caller; it does not send the call to Voice Mail.

Using the Styles feature, you can create styles, edit styles, view a style’s properties, delete styles, activate any style you have created, or turn off the active style.

To access the **Styles Menu**:

- 1 From the idle screen, press .

2 Press  to scroll to **Styles**.

3 Press  under SELECT.

From the **Styles Menu**, you can:

- activate a style or turn off the currently active style
- create a new style
- access the **Styles Action** menu for more Styles functions

Creating a Style

When you create a style, you give it a name and set the features of that style. The name of the style then appears on the Styles Menu.



To create a style:

1 From the **Styles Menu** screen, press  to scroll to **[New Style]**.

2 Press  under SELECT.

3 Assign a name to the style you are creating:

In the **Name** screen, use the alphanumeric keypad to enter the name you want to give the style.

As you type, you can delete a letter by pressing  under DELETE. To create a space, press  once.

Press  under OK.

4 In the **New** screen, press  to scroll through the settings for each style option.

5 To change any style option:

Press  to highlight the option.

Press  under CHANGE or SELECT.

Use the screens that appear to make your changes.

6 When all the style options have the settings you want, press  under DONE.

Editing a Style

To change the settings of a style:

1 From the **Styles Menu** screen, press  to scroll to the name of the style you want to edit.

2 Press  to access the **Styles Action** menu.

3 Press  to scroll to **Edit** and press  under SELECT.

4 To change any style option:

Press  to highlight the option.

Press  under CHANGE or SELECT.



Use the screens that appear to make your changes.

5 When all the style options have the settings you want, press  under DONE.

Activating a Style

When you access the **Styles Menu**, a check mark appears to the left of the name of the style that is currently active on your phone. If no style is active, the check mark appears next to **Off**. The active style name will appear on the idle screen.



To activate a style:

- 1 From the **Styles Menu** screen, press  to scroll to the name of the style you want to activate.
- 2 Press  under SELECT.

The style immediately becomes active on your phone and the style name displays on the idle screen.

Turning Off a Style

To turn off a style without activating another style:

- 1 From the **Styles Menu** screen, press  to scroll to **Off**.
- 2 Press  under SELECT.

Using the Styles Action Menu

When you highlight a style on the **Styles Menu**, you can then access the **Styles Action** menu for additional Styles functions.

To access the **Styles Action** menu, press  from the **Styles Menu**.

The **Styles Action** menu provides the following options:

- **View** — view settings of the highlighted style.
- **Change** — activate the highlighted style.
- **Edit** — edit the settings of the highlighted style.
- **New** — create a new style.
- **Delete** — delete the highlighted style.
- **Delete All** — delete all styles.

Setting Call Filtering

The Call Filter feature enables you to control which calls, messages, and alerts your phone responds to, and which it ignores.

From the **Call Filter** screen, you set separate filtering options for phone calls, Private and Group Calls, alerts, and messages:







- **Phone** — sets filtering options for phone calls.
- **Prvt/Grp** — sets filtering options for Private and Group Calls.
- **Alerts** — sets filtering options for Call Alerts.
- **Notifications** — sets filtering options for messages.



Setting Phone Call Filtering

Call Filter enables you to set your phone to respond to all calls, no calls, or only calls from some or all numbers in your Phonebook. Calls that are filtered out will be sent to Voice Mail unless you have modified your Call Forwarding settings.

- **Off** sets your phone to notify you of all calls.
- **All** sets your phone to ignore all calls.
- **All Phonebook** sets your phone to notify you only of calls from the numbers stored in your Phonebook.
- **Some Phonebook** sets your phone to notify you only of calls from numbers you select from your Phonebook. You may choose up to five Phonebook entries.

To choose Phonebook entries that you want your phone to respond to calls from:

| | |
|----------|---|
| 1 | From the Call Filter screen, press  to scroll Phone . |
| 2 | Press  under CHANGE. |
| 3 | Press  to scroll to Some Phonebook . |
| 4 | Press  under SELECT. The entries stored in your Phonebook appear. |
| 5 | To select a Phonebook entry as one you want to your phone to respond to, press  to scroll to the Phonebook entry and press  under SELECT. |
| | A check mark appears next to each selected Phonebook entry. You may select up to five Phonebook entries. |

- | | |
|---|---|
| 6 | To remove a selected Phonebook entry from the list, press  to scroll to the name and press  under SELECT. |
| 7 | When you have selected the Phonebook entries you want, press  under DONE. |

Setting Private and Group Call Filtering

Setting **Prvt/Grp** to **On** sets your phone to ignore all Private and Group Calls. Setting **Prvt/Grp** to **Off** sets your phone to respond to all Private and Group Calls.

Setting Alert Filtering

Setting **Alerts** to **On** sets your phone to ignore all Call Alerts. Setting **Alerts** to **Off** sets your phone to respond to all Call Alerts.

Setting Message Notification Filtering

Call Filter enables you to set your phone to notify you of certain types of messages, all types of messages, or no messages:

- **Off** allows your phone to notify you of all messages.
- **Voice Messages** allows your phone to notify you of Voice Mail messages.
- **Text Messages** allows your phone to notify you of Text Messages messages.
- **All** prevents your phone from notifying you of all messages.

Call Filter can prevent your phone from ringing or vibrating when you receive a message. Your display screen will still indicate that you have messages.



Shortcuts

The Shortcuts feature enables you to access most menu or submenu options in your phone by pressing a numeric button on the keypad or speaking a voice name for the shortcut. You create the shortcut to the menu by assigning a number to it and then accessing the menu by pressing the number. Some shortcuts may already be pre-programmed into your phone. You can have up to 20 total shortcuts.

Creating a Shortcut

- 1 Navigate to the menu item to which you want to create a shortcut.

For example, if you wanted to create a shortcut to **Ring/Vibe**:

From the idle screen, press , then press  to scroll to **Settings**.

Press  under SELECT. **Ring/Vibe** is now highlighted in the **Settings** screen.

- 2 Press and hold  for about 2 seconds.

- 3 A confirmation screen displays showing the name of the menu item to which you want to create a shortcut. To proceed with assigning the shortcut, press  under YES.

- 4 A screen displays showing the assigned shortcut number.

If you want to change the shortcut number:

Press  under CHANGE.

Press  under DELETE to erase the assigned number.

Enter the desired number on your keypad and press  under OK.

- 5 If you want to record a voice name for that shortcut:

Press  to highlight the **Voice** field.

Press  under RECORD.

As directed by the screen prompts, say and repeat the name you want to assign to the shortcut. Speak clearly into the microphone.



An  icon appears in the **Voice** field indicating that the voice name has been recorded.

USER TIP: For best results, record in a quiet environment.





- 6 Press  under DONE.

Using a Shortcut

To use a shortcut to access a menu:

- | | |
|---|---|
| 1 | From the idle screen, press  . |
| 2 | Press the number assigned to the shortcut. You have 2 seconds to do this after pressing  . |

Or,

- | | |
|---|--|
| 1 | From the idle screen, press  . |
| 2 | Press  to scroll to Shortcuts . |
| 3 | Press  under SELECT. |
| 4 | Press  to scroll to the shortcut you want to use. |
| 5 | Press  under GOTO. |

Or, if you have assigned the shortcut a voice name:

- | | |
|---|--|
| 1 | From the idle screen, press and hold  near the bottom of your phone until the phone beeps and the Say Name Now screen appears, then release. |
| 2 | Say the voice name assigned to the shortcut into your phone's microphone. Your phone will play the voice name back to you. |





Using the Shortcut Menu

The Shortcut Menu enables you to manage your shortcuts with the following options.

- **New** — view instructions for assigning a shortcut.

- **Edit** — edit a shortcut name and key number.
- **Reorder** — assign existing shortcuts to a different key number.
- **Delete** — delete any highlighted Shortcut.
- **Delete All** — delete all stored Shortcuts.

To access the **Shortcut** menu:

| | |
|---|--|
| 1 | From the idle screen, press  . |
| 2 | Press  to scroll to Shortcuts . |
| 3 | Press  under SELECT. |
| 4 | Press  to scroll to the desired shortcut. |
| 5 | Press  . |

Accessories

To order additional accessories or an accessories catalog, go to nextel.com or call Nextel NextdaySM Accessories at 1-800-914-3240. You can also contact your Nextel Authorized Sales Representative or stop by any Nextel Store. For information on Nextel retail store locations, go to nextel.com.

This section includes information on the following accessories:

| | |
|----------------------------|----------|
| Batteries | Page 165 |
| Travel Chargers | Page 166 |
| Universal Serial Bus (USB) | Page 168 |

Batteries

For best results, charge the batteries within the temperature range of 10°C to 40°C (50°F to 104°F).

Prolonged charging is not recommended. For battery charging guidelines, see Table below.

Charging Lithium Ion Batteries

The following table provides the approximate time to fully charge a battery using a Motorola iDEN Approved Lithium Ion battery charger. Check the item number on your battery and charger to determine the appropriate charging time.

Battery Charging Times

| MOTOROLA BATTERIES | | Charging Time to 100% | | |
|--------------------|-----------------------|----------------------------------|--------------------------------|-----------------------------------|
| Item Number | Description/Chemistry | Economy Travel Charger (SPN4808) | Rapid Travel Charger (SPN4716) | Mid Rate Travel Charger (SPN4940) |
| NTN9809 | Slim Battery | 2hrs30min | 2 hours | 2hrs30min |
| NTN9810 | Standard Battery | 4 hours | 2hrs30min | 4 hours |

NOTE: Charging times are based on a fully discharged battery.

Battery Operating Instructions

- Extreme temperatures will degrade battery performance. Do not store your battery where temperatures exceed 60°C (140°F) or fall below -20°C (4°F).
- Lithium Ion batteries have a self discharge rate and without use, will lose about 1% of its charge per day.
- The battery capacity will be degraded if stored for long periods while fully charged. If long term storage is required, store at half capacity.
- The Motorola iDEN Approved Lithium Ion chargers will provide optimum performance. Other chargers may not fully charge your iDEN Lithium Ion battery or may yield reduced number of lifetime charge cycles.
- When batteries are not in use, always store them in the plastic safety tray.

Travel Chargers

Using one of the Travel Chargers listed below, you can charge a battery from an AC outlet. On one end of the Travel Charger, an accessory connector attaches to the bottom of the phone. At the other (AC outlet) end of the device, there is a compact housing that contains the plug-in power supply.

| TRAVEL CHARGERS | |
|-----------------|---------------------------------------|
| Item Number | Description |
| SPN4940 | Mid-Rate Multi-Voltage Travel Charger |
| SPN4716 | Rapid Multi-Voltage Travel Charger |
| SPN4808 | Mid-Rate Economy Travel Charger |

NOTE: Additional adaptor plugs to accommodate various International power outlets can be purchased separately for the multi-voltage Travel Chargers.

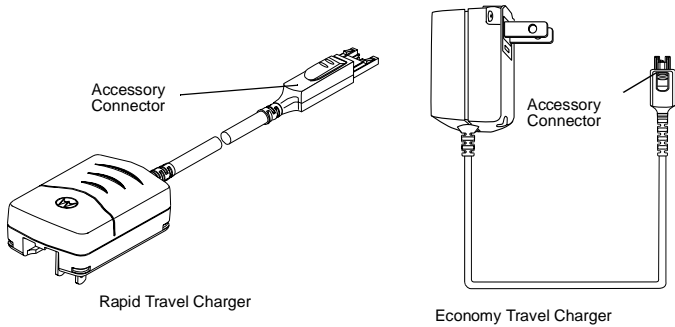

Using the Travel Charger

- 1 While holding the phone with its keypad facing up, insert the accessory connector into the bottom of the phone until you hear a click.
 - 2 If you have either the Mid-Rate Multi-Voltage Travel Charger or the Rapid Multi-Voltage Travel Charger, flip open the prongs, and plug the Travel Charger transformer into an AC wall outlet.
- Or,
- If you have the Mid-Rate Economy Travel Charger, plug the Travel Charger transformer into an AC wall outlet.

Universal Serial Bus (USB)

Your phone is able to communicate with USB-capable laptop and desktop computers.

The USB capable *i80s* phone supports both RS232 communications and USB communications (with USB mother devices). The *i80s* phone will automatically detect whether an RS232 or USB cable has been connected to it and will utilize the appropriate protocol. No other action is required in order to select between USB or RS232 serial communications.

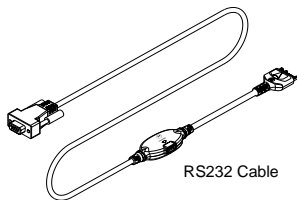
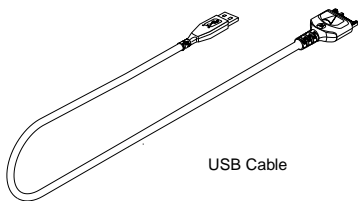

iDEN PC applications will support USB drivers for the following operating systems only:

- Windows 98
- Windows 2000
- Windows ME

Other Important Information

This section includes the following topics:

| | |
|--|----------|
| Nextel Customer Care | Page 169 |
| Understanding Status Messages | Page 170 |
| Nextel Terms and Conditions of Service | Page 172 |
| Safety and General Information | Page 178 |
| Limited Warranty Information | Page 189 |
| Patent and Trademark Information | Page 197 |

Nextel Customer Care

Relax! Nextel Customer Care is here to help. There are lots of features packed into your Nextel service...and into your *i80s* phone. But don't worry. If, after reading this guide, you still have questions about coverage, billing, Nextel Direct Connect or any other service or feature, contact us.

Domestic Customer Care

Visit nextel.com for a variety of Customer Care services:

- **Browse** for information on phones, coverage, rates and other Nextel services. View and download user's guides, try out our interactive virtual product and service demos, find answers to frequently asked questions, order accessories, locate service and repair centers, upgrade phone software, send a message and more.
- For self-service on your Nextel account, click on **My Account** to view your account, pay your bill, add phones to your account, reset your Voice Mail password, and more.
- For online assistance, click on **Contact Us** to send us an email request. Our representatives are committed to assisting you. Every effort will be made to address your questions or concerns within 24 hours. Contact us to add Wireless Web and other services, change rate plans, inquire on your bill and more.

Or, call us at 1-800-639-6111 or dial 611 from your Nextel phone.

International Roaming Customer Care

Call us at 1(201) 531-5202 (toll free) from your Nextel phone.

We'll be happy to give you help, explanations and anything else you need to enjoy your Nextel service as soon as possible!

Before you contact Nextel Customer Care for service or to resolve an issue, be sure to have your Nextel Personal Telephone Number, your model number (located on your phone underneath the battery), and the ID number printed on your SIM card. You'll want to record these numbers and keep them handy so that you can replace the battery prior to contacting Customer Care.

Understanding Status Messages

You may receive status messages under certain conditions. Before contacting Nextel Customer Care, note the message, numeric code, and the conditions under which it appeared. The following table lists and describes the status messages.

| Status Messages | Message Description |
|------------------------------|--|
| Number Not in Service | The number that you entered is not valid. |
| User Not Available | The phone that you called is either busy, out-of-coverage, or turned off. Please try again later. |
| User Not Authorized | The person that you called has not purchased this service. |
| Please Try Later | This service is temporarily not available. Please try again later. |
| User Busy in Private | The phone that you called is busy in a Private Call. |
| User Busy in Data | The phone that you called is busy using Nextel Wireless Web services or Nextel Online Dial-Up Service. |
| Service Restricted | This service was restricted by Nextel, or this service was not purchased. |

| Status Messages | Message Description |
|---|--|
| Service Not Available | This feature is not available on the current network. |
| System Busy Try Later | The system is experiencing heavy traffic. Please try again later. |
| Service Conflict | This service cannot be enabled because an incompatible service has already been turned on. |
| Please Try Again | An error occurred. Please try again. |
| Self Check Error | A fault was detected with your phone. If this error recurs, note the error code and contact Customer Care. |
| Self Check Fail | An operational fault was detected with your phone. Note the numeric code, turn your phone off, and contact Customer Care. |
| PIN Blocked Call Your Provider | The incorrect PIN was entered three consecutive times. You will be unable to place or receive calls on your <i>i80s</i> phone. Contact Nextel Customer Care to have them obtain the PIN Unblocking Key (PUK) code. |
| Insert SIM | Your SIM Card is not being detected. Please check to ensure that you have inserted the SIM Card. |
| Check SIM Card | Please check your SIM Card to make sure it has been inserted properly. |
| Wrong PIN | You have entered an incorrect PIN number. |
| Enter Special Code | Your phone will not accept a non-Nextel SIM card. |

Nextel Terms and Conditions of Service

TERMS AND CONDITIONS OF SERVICE: Before calling the Nextel Customer Care Service Activation number contained in these materials, you (“Customer”) must read and agree to the following terms and conditions of Nextel wireless communications services (“Service”). By calling to activate Service, Customer applies and subscribes for Services provided by Nextel (the “Company”) and confirms that Customer has read, understands, agrees to and accepts the terms and conditions stated herein (the “Agreement”). Should there be any conflict between the terms and conditions below, and the terms and conditions of any current Service/Subscriber Agreement between Customer and Company covering the phone and accessory equipment (the “Equipment”) accompanying this User’s Guide, the terms and conditions of the current Service/Subscriber Agreement will control.

1. USE OF SERVICE—By executing this Agreement, Customer acknowledges that it complies with all FCC rules and regulations. Customer will not use the Service for any unlawful purpose. Customer will not use the Service in aircraft in violation of FAA rules or regulations. Customer acknowledges and agrees that all future purchases of Company Services and Equipment by customer shall be governed by the terms and conditions contained herein unless Customer and Company enter into a subsequent Service/Subscriber Agreement. Company may change this Agreement at any time. Any changes are effective when Company provides Customer with written notice stating the effective date of the change(s). If Customer elects to use the Services or make any payment to Company on or after the effective date of the changes, Customer is deemed to have accepted the change(s). If Customer does not accept the changes, Customer may terminate Services as of the effective date at the address shown on Customer’s bill. If Services are terminated before the end of the current billing cycle, (i) no credit or refund will be provided for unused airtime; and (ii) any monthly recurring charge will not be prorated to the date of termination.

2. CREDIT APPLICATION—This Agreement shall be contingent upon Company’s approval of Customer’s credit application. Company may require Customer to update its credit application or information from time to time. Customer warrants and represents that all information furnished on the credit application is current, complete, accurate, and true. If Company subsequently determines that any statements made on the credit application are false, incomplete and inaccurate, Company may declare Customer to be in default under this Agreement and may exercise any remedies it has under this Agreement at law or in equity. Customer understands that Company will rely upon the credit information provided by Customer, including but not limited to Customer’s social security number or tax identification number, and other confidential and personal financial and credit information requested by Company and supplied by Customer, in making a decision to provide Services. Customer understands that Company may request and verify Customer’s bank references and perform a credit history check utilizing standard commercial credit reference services in connection with Company’s review of the Customer’s credit worthiness. Customer acknowledges that Company may provide payment history and other billing/charge information to a credit reporting agency for inclusion in Customer’s records maintained by such credit reporting agency. Customer understands that a security deposit or airtime usage limit may be required.

3. CUSTOMER RADIO EQUIPMENT—Company is not responsible for the installation, operation, quality of transmission, or maintenance of the Equipment. Any change in Service or Equipment may require additional programming or Equipment or changes to assigned codes or numbers which may require programming fees. Company reserves the

nextel.com

right to change or remove assigned codes and/or numbers when such change is reasonably necessary in the conduct of its business. Customer does not have any proprietary interest in such codes or numbers. Although Federal and state laws may make it illegal for third parties to listen in on service, complete privacy cannot be guaranteed. Company shall not be liable to Customer or to any third party for any eavesdropping on or interception of communications from Company's System.

4. **DEPOSITS**—Company has the right, exercisable in its sole discretion at any time or from time to time, to require Customer to make a deposit to guarantee payment of sums due hereunder, including Service charges. Customer hereby grants Company, as applicable, a security interest in such deposits, to secure the payment of all sums due hereunder as well as the performance of all other payment obligations Customer may have to the Company whether now existing or hereafter arising. Upon termination of Service, Company may apply the deposit against any outstanding Service charges of Customer or any other amount owed to Company. Company reserves the right to interrupt Services if Service appears to have excessive charges, payments are delinquent, or any unusual calling patterns are observed on Customer's account. Such interruption may be done to protect Customer or Company as the Company determines in its sole discretion, but in no event shall the Company be liable to the Customer or to any third party by reason of interrupting or failing to cause an interruption of Service.

5. **RATES, CHARGES, AND PAYMENT**—Company shall issue invoices for Service. Monthly Access charges shall be invoiced in advance. Airtime and long distance charges shall be invoiced in arrears. Customer is responsible to pay Company, on a timely basis, for charges by Company for Service. Customer acknowledges that chargeable time for telephone calls and Nextel Direct Connect call transmissions originated by a unit begin when a connection is established with Company facilities. A new Nextel Direct Connect call is initiated by a call participant if that participant responds more than six (6) seconds after the other party finishes its Nextel Direct Connect transmission. Customer accepts responsibility for Airtime charges from incoming telephone calls to its mobile unit from the time that Customer responds to the call. If Customer disputes any Service charges, Customer must pay the entire amount set forth in the invoice by the due date and submit a written explanation within forty-five (45) days from the date on the invoice. If Company determines that an error was made on Customer's invoice, Company shall credit Customer's account in the amount of the error. If Customer does not pay the amount in dispute, Company may exercise any remedies it may have under this Agreement for non-payment of Service charges. Company reserves the right to modify any and all elements of the Service charges at any time and each such modification shall be effective immediately upon the Company's communication thereof to Customer, unless the Company's communication indicates a later effective date with respect to such modification. Payments which are not received within thirty (30) days from the date of the invoice, shall be subject to late payment charges as set forth in this Agreement. If the parties have agreed that payments are to be made in installments, or on credit, Customer shall be responsible for paying amounts due as agreed. If Customer does not make all payments when they are due, such failure shall be a default under this Agreement and Company shall be entitled to exercise any remedies it may have under this Agreement or at law or in equity. If the sale of the Equipment is on a credit or installment basis and the Customer accepts delivery of the Equipment, the Customer may not return the Equipment or receive a refund or any amounts paid and agrees to continue making payments as required under this Agreement until the Equipment sale price is paid in full.

6. **NONPAYMENT/BREACH**—A late payment charge of 1.5% (or the maximum interest rate permitted by law) per month may be applied to Customer's account if monthly

invoices are not paid by the due date. The late payment charge is applied to the total unpaid balance due and outstanding. The late payment charge is for costs related to the non-timely payment and shall not be deemed an interest payment. A charge of \$25.00 will be made by Company for any check or negotiable instrument tendered by Customer and returned unpaid by a financial institution for any reason. Company may demand payment by money order, cashier's check, or similarly secure form of payment, at Company's discretion at any time or from time to time. If Company obtains the services of a collection or repossession agency or an attorney to assist Company in remedying Customer's breach of this Agreement, including but not limited to the nonpayment for charges hereunder, Customer shall be liable for this expense. Customer understands that in the event of nonpayment of charges or any other breach of the terms and conditions of this Agreement, in addition to any other remedies Company may have, Company may temporarily or permanently terminate Service to Customer. If Service is terminated and not reconnected within 30 days, all outstanding payments to be made in installments are accelerated and immediately due in full. If Company disconnects the Service, Customer shall be liable to satisfy and discharge all outstanding amounts due and pay a reconnect charge of \$25.00 per unit, in addition to any advance payment of Service charges that may be requested by the Company at its discretion, before the Company will reactivate Service. Company reserves the right to modify the terms of Service as a precondition to reactivating Service. If the Equipment is purchased on an installment basis, or credit, the Company may take possession of the Equipment, at any time wherever the same may be without legal process and without being responsible for loss and damage.

7. NEXTEL WIRELESS WEB SERVICES—Nextel Wireless Web Services, consisting of certain applications such as email, data, information and other wireless Internet services (the "Applications") are part of the Services that can be obtained through Company. Certain Applications offered by Company or authorized third parties may be compatible with the Equipment and/or the Service offered by Company. Customer acknowledges and agrees that there is no guarantee or assurance that the Applications are compatible, or will continue to be compatible, with Company's System or any of its Equipment or Service offerings. Such compatibility or approval from Company of compatibility shall not be construed as an endorsement of a particular Application or a commitment on the part of Company that Application(s) will continue to be compatible with the System, Equipment or Service for any period of time. Company reserves the right, in its sole discretion, to disable or discontinue any Application for any reason. Use of Nextel Wireless Web Services requires a wireless Internet compatible phone, and is subject to any storage, memory or other Equipment limitation. Only certain Internet sites may be accessed, and certain Nextel Wireless Web Services may not be available in all Company Service areas.

8. APPLICATION CUSTOMER CARE AND SUPPORT—Customer acknowledges and agrees that in most cases, the developer of an Application is responsible for providing customer care and Application support to all Customers using the Application. In the event Customer contacts Company customer care with a problem concerning the use of an Application, Customer may be referred to the Application developer's customer care, and Company shall have no obligation to support such Application.

9. CONTENT; INTELLECTUAL PROPERTY RIGHTS—Company is not a publisher of third party content that Customer may from time to time access through Nextel Wireless Web Services; therefore Company is not responsible for the content provided by such third parties, including but not limited to statements, opinions, graphics, photos, music, services and other information ("Content"), and accessed by Customer through Nextel Wireless Web Services. Company gives no guarantee or assurance as to the currency, accuracy, completeness or utility of Content obtained through Nextel Wireless Web

Services. Company, Content providers and others have proprietary interests in certain Content. Customer shall not, nor permit others, to reproduce, broadcast, distribute, sell, publish, commercially exploit or otherwise disseminate such Content in any manner without the prior written consent of Company, Content providers, or others with proprietary interests in such Content, as applicable.

10. RISK OF LOSS; INSURANCE—Upon Customer’s acceptance of delivery of the Equipment, all risk of loss, damage, theft, or destruction to the Equipment shall be borne by the Customer. No such loss, damage, theft, or destruction of the Equipment, in whole or part, shall impair the obligations of Customer hereunder, including, without limitation, responsibility for the payment of Service Charges due hereunder. If the Equipment is purchased on an installment basis, or on credit, Customer agrees to maintain, for the term of this Agreement, at its own expense, comprehensive public liability and property damage insurance with respect to its use of the Equipment in an amount not less than the replacement value of the Equipment, naming Company as co-insured, with all losses payable to Company. Certificates, evidencing proof of such policy and payment of premiums, shall be delivered to Company prior to delivery or installment of the Equipment. Customer shall prepay such premiums as required and shall furnish Company with proof of such payment at the beginning of the Payment Term and upon the expiration of any Certificate. Any and all amounts received by the Company under any such policy shall be applied by Company against the amount of the Equipment Sales Price and any related charges or fees secured hereby. Failure to provide or maintain the insurance required above is a breach of the Agreement for which the Company shall be entitled to exercise any remedies it may have under this Agreement.

11. PROPERTY DAMAGE INSURANCE—If Customer selects Direct Protect insurance protection, Company will remit the monthly charge for the insurance which appears on Customer’s bill to The Signal Telecommunications Insurance Services (“Signal”) on Customer’s behalf. Customer acknowledges that insurance protection is offered by the Signal, not Company, and that any requests for information or claims regarding the insurance shall be directed to Signal. Customer acknowledges having received a summary of coverage, including deductible information, which is also available by calling Signal at 1-888-352-9182.

12. TAXES, FEES, SURCHARGES & ASSESSMENTS—Customer is responsible for all federal, state, and local taxes, fees, surcharges, and other assessments (collectively, "charges") that are imposed on telecommunications services, other services, and equipment or that are measured by gross receipts from the sale of telecommunication services and/or equipment. Such charges shall include, but are not limited to: excise taxes; sales and transaction taxes; utility taxes; regulatory fees and assessments; universal service assessments, telephone relay service (TRS) assessments; etc. Customer shall be responsible for such charges regardless of whether the charge is imposed upon the sale of equipment or services, upon Customer, or upon Company. If any such charge is determined to be applicable and has not been paid by Customer before Customer accepts delivery of equipment, Customer shall pay Company the full amount of any such charge no later than ten (10) days after receipt of the invoice therefor.

13. COVERAGE AREA—Local Dispatch (Direct Connect), cellular calling, Nextel Wireless Web Services, and respective coverage areas for these Services are subject to change at any time at the sole discretion of Company.

14. LIMITATION AND CONDITION OF LIABILITY; INDEMNITY—Company does not assume and shall have no liability under the Agreement for (i) failure to deliver the Equipment within a specified time period; (ii) availability and delays in delivery of the

Equipment; (iii) damage caused to the Equipment due directly or indirectly to causes beyond the control of Company, including, but not limited to acts of God, acts of the public enemy, acts of the government, acts or failure to act of the Customer, its agents, employees or subcontractors, fires, floods, epidemics, quarantine restrictions, corrosive substances in the air or other hazardous environmental conditions, strikes, freight embargoes, inability to obtain materials or services, commotion, war, unusually severe weather conditions or default of Company's subcontractors whether or not due to any such causes; or (iv) the use of Nextel Wireless Web Services, including but not limited to the accuracy or utility of any information acquired from the Internet through Nextel Wireless Web Services; or Internet Services, Content or Applications whether or not supported by Company. Without limiting the foregoing, the Company's sole liability for Service disruption, whether caused by the negligence of the Company or otherwise, is limited to a credit allowance not exceeding an amount equal to the proportionate charge to the Customer for the period of Service disruption. EXCEPT AS OTHERWISE SET FORTH IN THE PRECEDING SENTENCE, IN NO EVENT IS THE COMPANY LIABLE FOR ACTUAL, CONSEQUENTIAL, INCIDENTAL, SPECIAL OR OTHER INDIRECT DAMAGES CAUSED BY ITS NEGLIGENCE OR OTHERWISE, NOR FOR ECONOMIC LOSS, PERSONAL INJURIES OR PROPERTY DAMAGES SUSTAINED BY THE CUSTOMER OR ANY THIRD PARTIES. Customer agrees to indemnify, defend, and hold Company harmless from any Customer violations of FCC rules and regulations or Customer violation of any statutes, ordinances or laws of any local, state, or federal public authority.

15. COMPLETE AGREEMENT/SEVERABILITY/WAIVER—This Agreement sets forth all of the agreements between the parties concerning the Service and purchase of the Equipment, and there are no oral or written agreements between them other than as set forth in this Agreement. No amendment or addition to this Agreement shall be binding upon this Company unless it is in writing and signed by both parties (and, in the case of the Company, by an officer of the Company). Company shall not be bound by the terms and conditions in Customer's purchase order or elsewhere, unless expressly agreed to in writing by an officer of the Company. This Agreement becomes effective when accepted by the Company. Should any provision of this Agreement be illegal or in contravention of the law, such provision shall be considered null and void but the remainder of this Agreement shall not be affected thereby. The failure of Company at any time to require the performance by Customer of the provisions of this Agreement shall not affect in any way the right to require such performances at any later time nor shall the waiver by Company of a breach of any provision hereof be taken or held to be a waiver of compliance with or breach of any other provision or a continuing waiver of such provision.

16. ASSIGNMENT/RESALE/GOVERNING LAW—This Agreement may be freely assigned by Company to any successor of it or any other firm or entity capable of performing its obligations hereunder, and upon any such assignment, Company shall be released from all obligations to Customer. Customer may not assign this Agreement, or resell the services which are subject to this Agreement without prior written consent of Company. Subject to the restrictions contained herein, this Agreement shall bind and inure to the benefit of the successors and permitted assigns of the parties hereto. This Agreement shall be governed by the laws of the State or Commonwealth in which this Agreement is executed by the Company.

17. NOTICE REGARDING USE OF SERVICE FOR 911 OR OTHER EMERGENCY CALLS—The Service provided hereunder does not interact with 911 and other emergency services in the same manner as landline telephone service. Depending on the

circumstances of a particular call, the Service provided hereunder may not be able to identify your location to emergency services and you may not always be connected to the appropriate emergency services provider. CUSTOMER AGREES TO HOLD COMPANY HARMLESS AGAINST ANY AND ALL CLAIMS, DEMANDS, ACTIONS, OR CAUSES OF ACTION (INCLUDING ALL ACTIONS BY THIRD PARTIES) ARISING OUT OF THE USE OR ATTEMPTED USE OF THE COMPANY'S SERVICE TO ACCESS 911 OR OTHER EMERGENCY SERVICES.

18. NO WARRANTY (SERVICE)—COMPANY MAKES NO WARRANTIES, EXPRESS OR IMPLIED, INCLUDING WITHOUT LIMITATION, ANY IMPLIED WARRANTY OF MERCHANTABILITY OR FITNESS FOR A PARTICULAR PURPOSE TO CUSTOMER IN CONNECTION WITH ITS USE OF THE SERVICE. IN NO EVENT SHALL COMPANY BE LIABLE FOR INCIDENTAL, CONSEQUENTIAL OR OTHER INDIRECT DAMAGES TO THE FULL EXTENT THE SAME MAY BE DISCLAIMED BY LAW. CUSTOMER ACKNOWLEDGES THAT SERVICE INTERRUPTIONS WILL OCCUR FROM TIME TO TIME, AND AGREES TO HOLD COMPANY HARMLESS FOR ALL SUCH INTERRUPTIONS.

19. NO WARRANTY (EQUIPMENT)—COMPANY MAKES NO WARRANTIES OR REPRESENTATIONS OF ANY KIND, STATUTORY, EXPRESS OR IMPLIED, TO CUSTOMER OR TO ANY OTHER PURCHASER OF THIS EQUIPMENT. WITHOUT LIMITING THE FOREGOING, COMPANY SPECIFICALLY MAKES NO EXPRESS OR IMPLIED WARRANTIES OF MERCHANTABILITY OR FITNESS FOR A PARTICULAR PURPOSE. CUSTOMER HEREBY WAIVES, AS AGAINST COMPANY, ALL OTHER WARRANTIES, GUARANTEES, CONDITIONS, OR LIABILITIES, EXPRESS OR IMPLIED, ARISING BY LAW OR OTHERWISE. IN NO EVENT SHALL COMPANY BE LIABLE FOR CONSEQUENTIAL, SPECIAL, OR INCIDENTAL DAMAGES, WHETHER OR NOT OCCASIONED BY COMPANY NEGLIGENCE AND INCLUDING, WITHOUT LIMITATION, LIABILITY FOR ANY LOSS OR DAMAGE RESULTING FROM THE INTERRUPTION OR FAILURE IN THE OPERATION OF ANY EQUIPMENT SOLD OR OTHERWISE PROVIDED HEREUNDER. THERE ARE NO WARRANTIES WHICH EXTEND BEYOND THE DESCRIPTION CONTAINED HEREIN. CUSTOMER ASSUMES THE ENTIRE RISK AS TO THE QUALITY AND PERFORMANCE OF THE EQUIPMENT. UNLESS OTHERWISE AGREED BY COMPANY, IF THE EQUIPMENT PROVES DEFECTIVE, THE COSTS OF ALL NECESSARY SERVICING AND REPAIR WILL BE BORNE BY CUSTOMER.

20. CERTAIN TERMS AND CONDITIONS REGARDING NEXTEL BUSINESS NETWORKS—There is no Group Call available on the Nextel Business Networks. There is no pooling of Nextel Direct Connect minutes between companies on the Nextel Business Networks. It is possible that participants on the Nextel Business Network could determine the private identification numbers of Customer's units and be able to Private Call those units. It is also possible that users of Customer's units could determine the private identification numbers of other Nextel Business Network participants and Private Call them.

Safety and General Information

IMPORTANT INFORMATION ON SAFE AND EFFICIENT OPERATION.

READ THIS INFORMATION BEFORE USING YOUR INTEGRATED MULTI-SERVICE PORTABLE RADIO.

RF Operational Characteristics

Your radio product contains a radio frequency transmitter to convey the information you wish to send as well as occasional automatic signals used to sustain connection to the wireless network, and a receiver which enables you to receive communication and connection information from the network.

PORTABLE RADIO PRODUCT OPERATION AND EME EXPOSURE

Your Motorola radio product is designed to comply with the following national and international standards and guidelines regarding exposure of human beings to radio frequency electromagnetic energy (EME):

- United States Federal Communications Commission, Code of Federal Regulations; 47 CFR part 2 sub-part J
- American National Standards Institute (ANSI) / Institute of Electrical and Electronics Engineers (IEEE). C95. 1-1992
- Institute of Electrical and Electronics Engineers (IEEE). C95. 1-1999 Edition
- National Council on Radiation Protection and Measurements (NCRP) of the United States, Report 86, 1986
- International Commission on Non-Ionizing Radiation Protection (ICNIRP) 1998
- Ministry of Health (Canada). Safety Code 6. Limits of Human Exposure to Radiofrequency Electromagnetic Fields in the Frequency Range from 3 kHz to 300 GHz, 1999.
- Australian Communications Authority Radiocommunications (Electromagnetic Radiation - Human Exposure) Standard 1999 (applicable to wireless phones only)

To assure optimal radio product performance and make sure human exposure to radio frequency electromagnetic energy is within the guidelines set forth in the above standards, always adhere to the following procedures:

Phone Operation

When placing or receiving a phone call, hold your radio product as you would a wireline telephone. **Speak directly into the microphone.**

Two-way radio operation

When using your radio product as a traditional two-way radio, **hold the radio product in a vertical position with the microphone one to two inches (2.5 to 5 cm) away from the lips.**



Body-worn operation

To maintain compliance with FCC RF exposure guidelines, if you wear a radio product on your body when transmitting, always place the radio product in a **Motorola approved clip, holder, holster, case or body harness for this product.** Use of non-Motorola-approved accessories may exceed FCC RF exposure guidelines. **If you do not use a Motorola approved body-worn accessory and are not using the radio product in the intended use positions along side of the head in the phone mode or in front of the face in the two-way radio mode, then ensure the antenna and the radio product is kept the following minimum distances from the body when transmitting:**

- **Phone or Two-way radio mode: one inch (2.5 cm)**
- **Data operation using any data feature with or without an accessory cable: one inch (2.5 cm)**

Antenna Care

Use only the supplied or an approved replacement antenna. Unauthorized antennas, modifications, or attachments could damage the radio product and may violate FCC regulations.

DO NOT hold the antenna when the radio product is “IN USE”. Holding the antenna affects call quality and may cause the radio product to operate at a higher power level than needed.

Approved Accessories

For a list of approved Motorola accessories call 1-800-453-0920, or visit our website at www.mot.com/iden, or look in the accessory section of this manual.

THIS MODEL PHONE MEETS THE GOVERNMENT'S REQUIREMENTS FOR EXPOSURE TO RADIO WAVES.

Your wireless phone is a radio transmitter and receiver. It is designed and manufactured not to exceed the emission limits for exposure to radiofrequency (RF) energy set by the Federal Communications Commission of the U.S. Government. These limits are part of comprehensive guidelines and establish permitted levels of RF energy for the general population. The guidelines are based on standards that were developed by independent scientific organizations through periodic and thorough evaluation of scientific studies. The standards include a substantial safety margin designed to assure the safety of all persons, regardless of age and health.

The exposure standard for wireless mobile phones employs a unit of measurement known as the Specific Absorption Rate, or SAR. The SAR limit set by the FCC is 1.6W/kg.* Tests for SAR are conducted using standard operating positions reviewed by the FCC with the phone transmitting at its highest certified power level in all tested frequency bands. Although the SAR is determined at the highest certified power level, the actual SAR level of the phone while operating can be well below the maximum value. This is because the phone is designed to operate at multiple power levels so as to use only the power required to reach the network. In general, the closer you are to a wireless base station antenna, the lower the power output.

Before a phone model is available for sale to the public, it must be tested and certified to the FCC that it does not exceed the limit established by the government-adopted requirement for safe exposure. The tests are performed in positions and locations (e.g., at the ear and worn on the body) as required by the FCC for each model. The highest SAR value for this model phone when tested for use at the ear is 1.37 W/kg and when tested on the body, as described in this user guide, is 0.89 W/kg during voice transmission using Phone Mode and 0.60 W/kg during packet data transmission. (Body-worn measurements differ among phone models, depending upon available accessories and FCC requirements.) While there may be differences between the SAR levels of various phones and at various positions, they all meet the government requirement for safe exposure.

The FCC has granted an Equipment Authorization for this model phone with all reported SAR levels evaluated as in compliance with the FCC RF exposure guidelines. SAR information on this model phone is on file with the FCC and can be found under the Display Grant section of <http://www.fcc.gov/oet/fccid> after searching on FCC ID AZ489FT5807.

Additional information on Specific Absorption Rates (SAR) can be found on the Cellular Telecommunications Industry Association (CTIA) web-site at <http://www.wow-com.com>.

* In the United States and Canada, the SAR limit for mobile phones used by the public is 1.6 watts/kg (W/kg) averaged over one gram of tissue. The standard incorporates a substantial margin of safety to give additional protection for the public and to account for any variations in measurements.

Electro Magnetic Interference/Compatibility

NOTE: Nearly every electronic device is susceptible to electromagnetic interference (EMI) if inadequately shielded, designed or otherwise configured for electromagnetic compatibility.

Facilities

To avoid electromagnetic interference and/or compatibility conflicts, turn off your radio product in any facility where posted notices instruct you to do so. Hospitals or health care facilities may be using equipment that is sensitive to external RF energy.

Aircraft

When instructed to do so, turn off your radio product when on board an aircraft. Any use of a radio product must be in accordance with applicable regulations per airline crew instructions.

Medical Devices

Pacemakers

The Health Industry Manufacturers Association recommends that a minimum separation of 6 inches (15 cm) be maintained between a handheld wireless radio product and a pacemaker. These recommendations are consistent with those of the U.S. Food and Drug Administration.

Persons with pacemakers should:

- ALWAYS keep the radio product more than 6 inches (15 cm) from their pacemaker when the radio product is turned ON.
- Not carry the radio product in a breast pocket.
- Use the ear opposite the pacemaker to minimize the potential for interference.
- Turn the radio product OFF immediately if you have any reason to suspect that interference is taking place.

Hearing Aids

Some digital wireless radio products may interfere with some hearing aids. In the event of such interference, you may want to consult your hearing aid manufacturer to discuss alternatives.

Other Medical Devices

If you use any other personal medical device, consult the manufacturer of your device to determine if it is adequately shielded from RF energy. Your physician may be able to assist you in obtaining this information.

Use While Driving

Check the laws and regulations on the use of radio products in the area where you drive. Always obey them.

When using the radio product while driving, please:

- Give full attention to driving and to the road.
- Use hands-free operation, if available.
- Pull off the road and park before making or answering a call if driving conditions so require.



WARNING

Operational Warnings

For Vehicles with an Air Bag

Do not place a portable radio product in the area over the air bag or in the air bag deployment area. Air bags inflate with great force. If a portable radio is placed in the air bag deployment area and the air bag inflates, the radio product may be propelled with great force and cause serious injury to occupants of the vehicle.

Potentially Explosive Atmospheres

Turn off your radio product prior to entering any area with a potentially explosive atmosphere, unless it is a radio product type especially qualified for use in such areas as “Intrinsically Safe” (for example, Factory Mutual, CSA, or UL approved). Do not remove, install, or charge batteries in such areas. Sparks in a potentially explosive atmosphere can cause an explosion or fire resulting in bodily injury or even death.

NOTE: The areas with potentially explosive atmospheres referred to above include fueling areas such as below decks on boats, fuel or chemical transfer or storage facilities, areas where the air contains chemicals or particles, such as grain, dust or metal powders, and any other area where you would normally be advised to turn off your vehicle engine. Areas with potentially explosive atmospheres are often but not always posted.

Blasting Caps and Areas

To avoid possible interference with blasting operations, turn off your radio product when you are near electrical blasting caps, in a blasting area, or in areas posted: “Turn off two-way radio”. Obey all signs and instructions.



Caution

Operational Cautions

Antennas

Do not use any portable radio product that has a damaged antenna. If a damaged antenna comes into contact with your skin, a minor burn can result.

Batteries

All batteries can cause property damage and/or bodily injury, such as burns if a conductive material such as jewelry, keys, or beaded chains touches exposed terminals. The conductive material may complete an electrical circuit (short circuit) and become quite hot. Exercise care in handling any charged battery, particularly when placing it inside a pocket, purse, or other container with metal objects.

Cleaning and Drying Considerations

Using a leather carry case may help protect the surfaces and help prevent liquids (e.g., rain) from entering into the interior of the radio product. This product is not water proof, and exposing the unit to liquids may result in permanent damage to the unit.

If your radio product interior gets wet, then do not try to accelerate drying with the use of an oven or a dryer as this will damage the radio product and void the warranty. Instead, do the following:

1. Immediately power off the radio product.
2. Remove Battery and SIM card (if so equipped) from radio product.
3. Shake excess liquid from radio product.
4. Place the radio product and battery in an area that is at room temperature and has good air flow.

5. Let the radio product, battery dry, and SIM card for 72 hours before reconnecting the battery and/or powering on the radio product.

If the radio product does not work after following the steps listed above, contact your dealer for servicing information.

Clean the external surfaces of the radio product with a damp cloth, using a mild solution of dishwashing detergent and water. Some household cleaners may contain chemicals that could seriously damage the radio product. Avoid the use of any petroleum-based solvent cleaners. Also, avoid applying liquids directly on the radio product.

Accessory Safety Information

IMPORTANT:

SAVE THESE ACCESSORY SAFETY INSTRUCTIONS

- Before using any battery or battery charger, read all the instructions for and cautionary markings on (1) the battery, (2) the battery charger, which may include a separate wall-mounted power supply or transformer, and (3) the radio product using the battery.
- Do not expose any battery charger to water, rain, or snow as they are designed for indoor or in-vehicle use only.

| | |
|---|--|
|  <p>WARNING</p> | <p>To reduce the risk of injury, charge only the rechargeable batteries listed in the Accessories section of this manual. Other types of batteries may burst, causing personal injury and damage.</p> |
|---|--|

- To reduce the risk of damage to the cord or plug, pull by the plug rather than the cord when you disconnect the battery charger from the power source outlet.
- Do not operate any battery charger with a damaged cord or plug — replace them immediately.
- Battery chargers may become warm during operation, but not hot. If it becomes hot to the touch, unplug it from the power outlet immediately and discontinue its use.
- Use of a non-recommended attachment to a battery charger may result in a risk of fire, electric shock, or injury to persons.
- Make sure the battery charger power cord is located so that it will not be stepped on, tripped over, or subjected to damage or stress.
- An extension cord should not be used with any battery charger unless absolutely necessary. Use of an improper extension cord could result in a risk of fire and electric shock. If an extension cord must be used, make sure that:
 - The pins on the plug of the extension cord are the same number, size, and shape as those on the plug of the charger.
 - The extension cord is properly wired and in good electrical condition.
 - The cord size is 18AWG for lengths up to 100 feet and 16AWG for lengths up to 150 feet.

- Do not operate any battery charger if it has received a sharp blow, has been dropped, or has been damaged in any way; take it to a qualified service technician.
- Do not disassemble a battery charger; take it to a qualified service technician when service or repair is required. Incorrect reassembly may result in a risk of electric shock or fire.
- Maximum ambient temperature around the power supply or transformer of any battery charger should not exceed 40°C (104°F).
- The output power from the power supply or transformer must not exceed the rating given on the Desktop Dual-Pocket Charger.
- The disconnection from the line voltage is made by unplugging the power supply from the AC receptacle.
- To reduce risk of electric shock, unplug any battery charger from the outlet before attempting any maintenance or cleaning.

For optimum charging performance, turn off the radio product while charging it in any battery charger.

Limited Warranty Motorola Communication Products

NOTE :

This Warranty applies within the fifty (50) united states and the District of Columbia

I. WHAT THIS WARRANTY COVERS AND FOR HOW LONG:

MOTOROLA, INC. (“MOTOROLA”) warrants the MOTOROLA manufactured iDEN Communication Products listed below (“Product”) against defects in material and workmanship under normal use and service for a period of time from the date of purchase as scheduled below:

| | |
|--|---------------------|
| iDEN Subscriber Digital Mobile and Portable Units | One (1) Year |
| Product Accessories | One (1) Year |
| Batteries | One (1) Year |

Rechargeable Batteries will be replaced during the applicable warranty period if:

- a. the battery capacity falls below 80% of rated capacity, or
- b. the battery develops leakage.

MOTOROLA, at its option, will at no charge either repair the Product (with new or reconditioned parts), replace it (with a new or reconditioned Product), or refund the purchase price of the Product during the warranty period provided it is returned in accordance with the terms of this warranty. Replaced parts or boards are warranted for the balance of the original applicable warranty period. All replaced parts of Product shall become the property of MOTOROLA.

This express limited warranty is extended by MOTOROLA to the original end user purchaser only and is not assignable or transferable to any other party. This is the complete warranty for the Product manufactured by MOTOROLA. MOTOROLA assumes no obligations or liability for additions or modifications

to this warranty unless made in writing and signed by an officer of MOTOROLA. Unless made in a separate agreement between MOTOROLA and the original end user purchaser, MOTOROLA does not warrant the installation, maintenance or service of the Product.

MOTOROLA cannot be responsible in any way for any ancillary equipment not furnished by MOTOROLA which is attached to or used in connection with the Product, or for operation of the Product with any ancillary equipment, and all such equipment if expressly excluded from this warranty. Because each system which may use the Product is unique, MOTOROLA disclaims liability for range, coverage, or operation of the system as a whole under this warranty.

II. GENERAL PROVISIONS:

This warranty sets forth the full extent of MOTOROLA'S responsibilities regarding the Product, Repair, replacement or refund of the purchase price, at MOTOROLA'S options, is the exclusive remedy. THIS WARRANTY IS GIVEN IN LIEU OF ALL OTHER EXPRESS WARRANTIES. IMPLIED WARRANTIES, INCLUDING WITHOUT LIMITATION, IMPLIED WARRANTIES OF MERCHANTABILITY AND FITNESS FOR A PARTICULAR PURPOSE, ARE LIMITED TO THE DURATION OF THIS LIMITED WARRANTY. IN NO EVENT SHALL MOTOROLA BE LIABLE FOR DAMAGES IN EXCESS OF THE PURCHASE PRICE OF THE PRODUCT, FOR ANY LOSS OF USE, LOSS OF TIME, INCONVENIENCE, COMMERCIAL LOSS, LOST PROFITS OR SAVINGS OR OTHER INCIDENTAL, SPECIAL OR CONSEQUENTIAL DAMAGES ARISING OUT OF THE USE OR INABILITY TO USE SUCH PRODUCT, TO THE FULL EXTENT SUCH MAY BE DISCLAIMED BY LAW.

III. STATE LAW RIGHTS:

SOME STATES DO NOT ALLOW THE EXCLUSION OR LIMITATION OF INCIDENTAL OR CONSEQUENTIAL DAMAGES, OR LIMITATION ON HOW LONG AN IMPLIED WARRANTY LASTS, SO THE ABOVE LIMITATIONS OR EXCLUSIONS MAY NOT APPLY.

This warranty gives specific legal rights, and there may be other rights which may vary from state to state.

IV. HOW TO GET WARRANTY SERVICE:

You must provide proof of purchase (bearing the date of purchase and Product item serial number) in order to receive warranty service and, also, deliver or send the Product item, transportation and insurance prepaid, to an authorized warranty service location. Warranty service will be provided by MOTOROLA through one of its authorized warranty service locations. If you first contact the company which sold you the Product (e.g., dealer or communication service provider), it can facilitate your obtaining warranty service. You can also call MOTOROLA at 1-800-453-0920 for warranty service location information.

V. WHAT THIS WARRANTY DOES NOT COVER:

- a. Defects or damage resulting from use of the Product in other than its normal and customary manner.
- b. Defects or damage from misuse, accident, water, or neglect.
- c. Defects or damage from improper testing, operation, maintenance, installation, alteration, modification, or adjustment.
- d. Breakage or damage to antennas unless caused directly by defects in material workmanship.
- e. A Product subjected to unauthorized Product modifications, disassemblies or repairs (including, without limitation, the audition to the Product of non-MOTOROLA supplied equipment) which adversely affect performance of the Product or interfere with MOTOROLA'S normal warranty inspection and testing of the Product to verify any warranty claim.
- f. Product which has had the serial number removed or made illegible.
- g. Rechargeable batteries if:
 1. Any of the seals on the battery enclosure of cells are broken or show evidence of tampering.
 2. The damage or defect is caused by charging or using the battery in equipment or service other than the Product for which it is specified.
- h. Freight costs to the repair depot.
- i. A Product which, due to illegal or unauthorized alteration of the software/firmware in the Product, does not function in accordance with MOTOROLA'S published specifications or the FCC type acceptance labeling in effect for the Product at the time the Product was initially distributed from MOTOROLA.
- j. Scratches or other cosmetic damage to Product surfaces that does not effect the operation of the Product.

- k. Normal and customary wear and tear.

VI. PATENT AND SOFTWARE PROVISIONS:

MOTOROLA will defend, at its own expense, any suit brought against the end user purchaser to the extent that it is based on a claim that the Product or parts infringe a United States patent, and Motorola will pay those costs and damages finally awarded against the end user purchaser in any such suit which are attributable to any such claim, but such defense and payments are conditioned on the following:

- a. That MOTOROLA will be notified promptly in writing by such purchaser of any notice of such claim;
- b. That MOTOROLA will have sole control of the defense of such suit and all negotiations for its settlement or compromise; and
- c. Should the Product or parts become, or in MOTOROLA'S opinion be likely to become, the subject of a claim of infringement of a United States patent, that such purchaser will permit MOTOROLA, at its option and expense, either to procure for such purchaser the right to continue using the Product or parts or to replace or modify the same so that it becomes non-infringing or to grant such purchaser a credit for the Product or parts as depreciated and accept its return. The depreciation will be an equal amount per year over the lifetime of the Product or parts as established by MOTOROLA.

MOTOROLA will have no liability with respect to any claim of patent infringement which is based upon the combination of the Product or parts furnished hereunder with software, apparatus or devices not furnished by MOTOROLA, nor will MOTOROLA have any liability for the use of ancillary equipment or software not furnished by MOTOROLA which is attached to or used in connection with the Product or any parts thereof.

Laws in the United States and other countries preserve for MOTOROLA certain exclusive rights for copyrighted MOTOROLA software, such as the exclusive rights to reproduce in copies and distribute copies of such MOTOROLA software. MOTOROLA software may be used in only the Product in which the software was originally embodied and such software in such Product may not be replaced, copied, distributed, modified in any way, or used to produce any derivative thereof. No other use including, without limitation, alteration, modification, reproduction, distribution, or reverse engineering of such MOTOROLA software or exercise or rights in such MOTOROLA software is permitted. No license is granted by implication, estoppel or otherwise under MOTOROLA patent rights or copyrights.

Limited Warranty Motorola Communication Products (International)

| | |
|---------------|---|
| NOTE : | This Warranty applies in Singapore and the Philippines. |
|---------------|---|

I. WHAT THIS WARRANTY COVERS AND FOR HOW LONG:

MOTOROLA warrants the MOTOROLA manufactured iDEN Communication Products listed below (“Product”) against defects in material and workmanship under normal use and service for a period of time from the date of purchase as scheduled below:

| | |
|---|---------------------|
| iDEN Subscriber Digital Mobile and Portable Units | One (1) Year |
| Product Accessories (manufactured by or under license from MOTOROLA) | One (1) Year |
| Batteries | One (1) Year |

Rechargeable Batteries will be replaced during the applicable warranty period if:

- a. the battery capacity falls below 80% of rated capacity, or
- b. the battery develops leakage.

MOTOROLA, at its option, will at no charge either repair the Product (with new or reconditioned parts), replace it (with a new or reconditioned Product), or refund the purchase price of the Product during the warranty period provided it is returned in accordance with the terms of this warranty. Replaced parts or boards are warranted for the balance of the original applicable warranty period. All replaced parts of Product shall become the property of MOTOROLA.

This express limited warranty is extended by MOTOROLA to the original end user purchaser only and is not assignable or transferable to any other party. This is the complete warranty for the Product manufactured by MOTOROLA. MOTOROLA assumes no obligations or liability for additions or modifications

to this warranty unless made in writing and signed by an officer of MOTOROLA. Unless made in a separate agreement between MOTOROLA and the original end user purchaser, MOTOROLA does not warrant the installation, maintenance or service of the Product.

MOTOROLA cannot be responsible in any way for any ancillary equipment not furnished by MOTOROLA which is attached to or used in connection with the Product, or for operation of the Product with any ancillary equipment, and all such equipment if expressly excluded from this warranty. Because each system which may use the Product is unique, MOTOROLA disclaims liability for range, coverage, or operation of the system as a whole under this warranty.

II. GENERAL PROVISIONS:

This warranty sets forth the full extent of MOTOROLA'S responsibilities regarding the Product, Repair, replacement or refund of the purchase price, at MOTOROLA'S options, is the exclusive remedy. THIS WARRANTY IS GIVEN IN LIEU OF ALL OTHER EXPRESS WARRANTIES. IMPLIED WARRANTIES, INCLUDING WITHOUT LIMITATION, IMPLIED WARRANTIES OF MERCHANTABILITY AND FITNESS FOR A PARTICULAR PURPOSE, ARE LIMITED TO THE DURATION OF THIS LIMITED WARRANTY TO THE FULL EXTENT SUCH MAY BE DISCLAIMED BY LAW. IN NO EVENT SHALL MOTOROLA BE LIABLE FOR DAMAGES IN EXCESS OF THE PURCHASE PRICE OF THE PRODUCT, FOR ANY LOSS OF USE, LOSS OF TIME, INCONVENIENCE, COMMERCIAL LOSS, LOST PROFITS OR SAVINGS OR OTHER INCIDENTAL, SPECIAL OR CONSEQUENTIAL DAMAGES ARISING OUT OF THE USE OR INABILITY TO USE SUCH PRODUCT, TO THE FULL EXTENT SUCH MAY BE DISCLAIMED BY LAW.

III. HOW TO GET WARRANTY SERVICE:

You must provide proof of purchase (bearing the date of purchase and Product item serial number) in order to receive warranty service and, also, deliver or send the Product item, transportation and insurance prepaid, to an authorized warranty service location. Warranty service will be provided by MOTOROLA through one of its authorized warranty service locations. If you first contact the company which sold you the Product (e.g., dealer or communication service provider), it can facilitate your obtaining warranty service.

IV. WHAT THIS WARRANTY DOES NOT COVER:

- a. Defects or damage resulting from use of the Product in other than its normal and customary manner.

- b. Defects or damage from misuse, accident, water, or neglect.
- c. Defects or damage from improper testing, operation, maintenance, installation, alteration, modification, or adjustment.
- d. Breakage or damage to antennas unless caused directly by defects in material workmanship.
- e. A Product subjected to unauthorized Product modifications, disassemblies or repairs (including, without limitation, the audition to the Product of non-MOTOROLA supplied equipment).
- f. Product which has had the serial number removed or made illegible.
- g. Rechargeable batteries if:
 - 1. Any of the seals on the battery enclosure of cells are broken or show evidence of tampering.
 - 2. The damage or defect is caused by charging or using the battery in equipment or service other than the Product for which it is specified.
- h. Freight costs to the repair depot.
- i. A Product which, due to illegal or unauthorized alteration of the software/firmware in the Product, does not function in accordance with MOTOROLA'S published specifications or the local type acceptance labeling in effect for the Product at the time the Product was initially distributed from MOTOROLA.
- j. Scratches or other cosmetic damage to Product surfaces that does not effect the operation of the Product.
- k. Normal and customary wear and tear.
- l. Exclusion for defects or damage arising from use of the products in connection with non-MOTOROLA equipment.

V. PATENT AND SOFTWARE PROVISIONS:

MOTOROLA will defend, at its own expense, any suit brought against the end user purchaser to the extent that it is based on a claim that the Product or parts infringe a patent, and Motorola will pay those costs and damages finally awarded against the end user purchaser in any such suit which are attributable to any such claim, but such defense and payments are conditioned on the following:

- a. That MOTOROLA will be notified promptly in writing by such purchaser of any notice of such claim;
- b. That MOTOROLA will have sole control of the defense of such suit and all negotiations for its settlement or compromise; and

- c. Should the Product or parts become, or in MOTOROLA'S opinion be likely to become, the subject of a claim of infringement of a patent, that such purchaser will permit MOTOROLA, at its option and expense, either to procure for such purchaser the right to continue using the Product or parts or to replace or modify the same so that it becomes non-infringing or to grant such purchaser a credit for the Product or parts as depreciated and accept its return. The depreciation will be an equal amount per year over the lifetime of the Product or parts as established by MOTOROLA.

MOTOROLA will have no liability with respect to any claim of patent infringement which is based upon the combination of the Product or parts furnished hereunder with software, apparatus or devices not furnished by MOTOROLA, nor will MOTOROLA have any liability for the use of ancillary equipment or software not furnished by MOTOROLA which is attached to or sued in connection with the Product or any parts thereof. In no event shall MOTOROLA be liable for any incidental, special or consequential damages arising from any claim of patent infringement or alleged infringement.

Laws in the United States and other countries preserve for MOTOROLA certain exclusive rights for copyrighted MOTOROLA software, such as the exclusive rights to reproduce in copies and distribute copies of such MOTOROLA software. MOTOROLA software may be used in only the Product in which the software was originally embodied and such software in such Product may not be replaced, copied, distributed, modified in any way, or used to produce any derivative thereof. No other use including, without limitation, alteration, modification, reproduction, distribution, or reverse engineering of such MOTOROLA software or exercise or rights in such MOTOROLA software is permitted. No license is granted by implication, estoppel or otherwise under MOTOROLA patent rights or copyrights.

Patent and Trademark Information

© 2001 Nextel Communications Inc. Nextel, the Nextel logo, and all other Nextel product and/or service names referenced throughout this guide are either a trademark, service mark or registered trademark of Nextel Communications, Inc. All rights reserved.

MOTOROLA, the Stylized M Logo and all other trademarks indicated as such herein are trademarks of Motorola, Inc. ® Reg. U.S. Pat. & Tm. Off. © 2001 Motorola, Inc. All rights reserved.

Microsoft and Microsoft Internet Explorer are registered trademarks of Microsoft Corporation.

Netscape Navigator is a registered trademark of Netscape Communications Corporation.

T9 is a trademark owned by Tegic Communications.

T9® Text Input Patent and Trademark Information

This product is covered by U.S. Pat. 5,818,437, U.S. Pat. 5,953,541, U.S. Pat. 6,011,554 and other patents pending.

Java and all other Java-based marks are trademarks or registered trademarks of Sun Microsystems, Inc. in the U.S. and other countries.

Direct Protect is a trademark of Signal Insurance Company.

All other product names and services are the property of their respective trademark owners.

A

- Accessories **165**
 - batteries **165**
 - Travel Charger **166**
- accessories **3**
- Accessory safety information **186**
- Active Line icons **32**
- Address Book **52**
- Alarm **120**
 - Datebook **120**
- Alpha mode, text entry **26**
- Alternate Line **75**
 - receiving calls **76**
 - selecting **76**
- Answer **106**
- Auto Redial **151**

B

- Back
 - Nextel Wireless Web **133**
- Backlight **150**
- Backlight Timer **152**
 - Customizing the i55sr Phone **152**
- Battery **9**
 - attaching **9**
 - charge strength **10**
 - charging **10**
 - detaching **9**
 - operating **166**
- Battery Charging Times **166**
 - Accessories **166**
- Battery Strength icons **32**
- Blocking **75**
 - Digital Cellular **75**

- Business Networks **101**

C

- Call Alert **37, 104**
 - Messages **37**
- Call Alert Queue **106**
- Call alerts **104**
 - from Phonebook **105**
 - receiving **106**
- Call Filtering **159**
- Call Forward **36**
- Call Forward icons **32**
- Call Forwarding **70**
 - turning off **72**
 - turning on **71**
- Call Hold **68**
- Call restrictions **77**
- Call Timers **36, 66**
 - Digital Cellular **36**
- Call Waiting **66, 146**
 - accepting calls **67**
 - declining calls **67**
 - ending active calls **68**
 - switching between calls **67**
 - turning off **68**
- Caller ID **74**
- Charge strength **10**
- Chargers
 - Accessories **166**
- Charging Lithium Ion Batteries **165**
 - Accessories **165**
- Charging Lithium Ion batteries
 - Accessories **165**
- Circuit data number **23**
- Clear **106**

Connection status **23**
 Contrast **152**
 coverage **2**
 Customer Care **2, 169**
 Customer Support **2**
 Customizing Java applications **139**

D

Datebook **36, 113**
 set up **123**
 viewing **114**
 viewing a day **115**
 viewing a week **115**
 viewing event details **116**
 viewing today **116**
 Datebook events **116**
 adding **117**
 deleting **122**
 editing **121**
 Datebook icons **114**
 Deactivating **22**
 Deinstalling
 Java Apps **139**
 Delete
 Customizing the i55sr Phone
 164
 Shortcut Menu **164**
 Deleting **108**
 Delivery options
 Voice Mail **89**
 Dialing menu **49**
 Dial-Up Service
 Nextel Wireless Web **135**
 Digital cellular **53**
 Direct Connect **101**
 Direct Dial **54**
 Digital Cellular **54**
 Direct dial **54**

Direct ProtectSM insurance **3**
 Directory Assistance **77**
 Display options **34**
 changing **148**
 Driving safety **3**

E

Earpiece **155**
 Voice Volume **155**
 Email **99**
 Emergency Calling **59**
 Emergency calling
 Digital Cellular **59**
 Entering text, see Text entry
 Error **171**

F

Feature Reset **153**

G

Getting started **5**
 Greetings **86**
 Group calls **108**
 Group-Silent **111**
 Direct Connect **111**
 Group-Silent Programming **111**

H

Hold **68**
 Digital Cellular **68**
 Home
 Nextel Wireless Web **133**

I

Icon **71**
 Digital Cellular **71**
 Icons **8**
 context sensitive **32**
 Datebook **114**

- main menu **36**
- Phonebook **40**
- status **32**
- Idle screen **32**
- In Call Setup **146**
- Initial Setup **150**
- International calls **52, 58**
- International Roaming Customer **2**
- Internet **133**
 - security **134**
- IP Address **23**

J

- Java applications **137**
 - custom **139**
 - installing **138**
 - memory **140**
- Java Apps **36**
 - Java **36**

K

- Keypad Lock **20, 146, 147**
 - activating **20**
 - deactivating **22**

L

- Language **26, 153**
- Line **145**

M

- Main menu **37**
 - icons **36**
 - options **36**
 - reordering **148**
- Making call alerts **104**
- Making Phone Calls **54**
 - Digital Cellular **54**
- Making phone calls **54**
- Making Private calls **102**

- Master Clear **153**
- Master Reset **148**
- Memo **36, 125**
 - adding **125**
 - deleting **126**
 - editing **126**
 - viewing **125**

- Memory
 - Java **140**
 - Voice Notes **131**

- Menu icon **34**

- Menus **7, 34, 35**
 - main menu **37**
 - Styles Actions menu **159**
 - Styles menu **157**
 - voice mail **82**

- Message Center **95**

- Message indicators
 - text and numeric **97**
 - voice mail **80**

- Messages **36, 95**
 - email **99**
 - Net Mail **99**
 - text and numeric **96**
 - voice mail **79**

- Messages, text and numeric
 - notifications **97**
 - operator assisted **99**
 - sending **98**
 - viewing **97**
 - Web **99**

- Microbrowser **134**

- Missed call **61**

- Mobile IP **33**

- Modem, phone as **135**

- Mute **66**

- My Info **37**
 - Getting Started **37**

My Information **23**

N

Navigating

Menus **35**

Navigating Menus and Lists **35**

Navigation

KeysNextel Wireless Web **133**

Net **36, 133**

Net Mail **99**

Nextel **53**

Business Networks **101**

Customer Care **2, 169**

Direct Connect **101**

Direct ProtectSM insurance **3**

Internet Home Page **3**

Online Dial-Up Service **135**

Terms and Conditions of Service
172

Wireless Web **133**

Nextel Mobile Messaging **95**

Nextel OnlineSM Service Plan **133**

Nextel Wireless Web **133**

Nextel Worldwide Service **53**

Digital Cellular **53**

Notifications **146**

setting **145**

text and numeric messages **97**

Numeric mode, text entry **29**

O

OARSS **12**

Ordering Information **3**

over-the-air programming **12**

P

Packet data activity **33**

Packet data ready **33**

Password **79, 84**

SIM PIN **147**

unlock code **147**

voice mail **84**

Patent information **197**

Pause digit entry **51**

Per-Call blocking **75**

Per-Line blocking **75**

Personalize **148**

Phone

modem **135**

off **11**

on **11**

status **23**

Phone calls **54**

call restrictions **77**

displaying caller's name **75**

ending **60**

from Phonebook **54**

from Recent Calls list **56**

international calls **58**

receiving **60**

speed dial **57**

Turbo Dial **57**

voice names **57**

Phone In Use **32**

Phone Lock **146, 147**

Phone Setup **145**

Phonebook **36, 39**

capacity **44**

making call alerts **105**

making calls **54**

Phonebook Entries **36**

Private calls **102**

storing Recent Calls **63**

Phonebook entries **42**

adding **45**

deleting **51**

- editing **50**
- sorting **43**
- viewing **42**
- Phonebook Icons
 - Phonebook **40**
- Placing
 - Direct Connect **104**
- Plus Dialing **58**
- Plus dialing **52**
- Power button **11**
- Powering phone on or off **11**
- Privacy **75**

- Private calls
 - from Phonebook **102**
 - from Recent Calls list **103**
 - making **102**
 - receiving **104**
 - voice names **103**

- Private in use **33**
- PUK code **17**

Q

- Queue **106**
 - Direct Connect **106**
- queue
 - Direct Connect **106**

R

- Radio frequency **178**
- rates **2**
- Receiving a phone call
 - Digital Cellular **60**
- Recent Calls **37, 50, 56, 61**
 - deleting **63**
 - details **62**
 - Digital Cellular **37**
 - Private calls **103**
 - storing to Phonebook **63**

- viewing **61**
- Recording Your Name
 - VoiceMail **85**
- Redial **58**
 - Digital Cellular **58**
- Responding **107**
- Ring styles **144**
- Ring/Vibe **142**
- Ring/Vibe icons **33**
- Ringer Vol **142**
- Running
 - Java Apps **138**

S

- Safety **178**
 - accessory **186**
 - electromagnetic interference
 - 181**
 - medical devices **181**
 - radio frequency **178**

- Screen **31**

- Scroll **133**

- Nextel Wireless Web **133**

- Scrolling **35, 152**

- Customizing the i55sr Phone
 - 152**

- Secure Data **33**

- Security **13, 134, 146**

- Security code

- Password **147**

- Settings **36**

- In Call Setup **146**

- Initial Setup **150**

- Personalize **148**

- Phone Setup **145**

- Ring/Vibe **142**

- VoiceVolume **155**

- Shortcut Menu **63**

- Shortcuts **37, 161**
 - creating **162**
 - Customizing **37**
 - using **163**
 - Signal strength icons
 - Display **32**
 - SIM card **13, 39**
 - blocked **15**
 - inserting and removing **18**
 - unblocking **17**
 - SIM PIN **13, 14, 147**
 - changing **16**
 - disabling **13, 18**
 - enabling **13, 18**
 - entering **13, 14**
 - Sorting **107**
 - Speakerphone **65**
 - Speed Dial numbers **40, 47, 57**
 - Status Light **152**
 - Status light **23**
 - Status messages **170**
 - Status of connection **23**
 - Storing Numbers **49**
 - Phonebook **49**
 - Styles **156**
 - activating **158**
 - creating **157**
 - turning off **159**
 - Symbols mode, text entry **29**
- T**
- T9 Text Input **24**
 - also see Text entry
 - T9 Text Input icons **33**
 - Talkgroup **156**
 - Talkgroup In Use **33**
 - Talkgroups **108**
 - joining **110**
 - naming **109**
 - TDD/TTY **60**
 - Telecommunications Relay Service **60**
 - Terms and Conditions of Service **172**
 - Text and numeric messages **96**
 - Text display
 - area **34**
 - Text entry **24**
 - Alpha mode **26**
 - Numeric mode **29**
 - Symbols mode **29**
 - Word mode **27**
 - Text Message **33**
 - Text messages **33**
 - Three-Way Calling **69**
 - Time and date charts
 - Voice Mail **93**
 - Time and date format **150**
 - Timer **146**
 - Trademark information **197**
 - Transferring calls to voice mail
 - VoiceMail **81**
 - TTY devices
 - making calls **59**
 - setting baud rate **155**
 - setting mode **154**
 - Turbo Dial **57**
 - Turning phone on or off **11**
 - Two-Way Messages **99**
 - Two-Way Messaging **95**
 - Two-way radio **101**
 - also see Direct Connect or Private calls
 - Typing text, see Text entry
- U**
- Unblocking SIM PIN **17**

Universal Serial Bus (USB) **168**

V

VibeAll **143**

Vibrate All **144**

 Customizing the i55sr Phone
 144

Viewing **106**

Viewing Datebook **114**

Voice **127**

Voice Activated dialing **57, 103**
 also see voice names

Voice Mail **33, 79, 94**

 changing password **84**

 deleting messages **83**

 greetings **85**

 group lists **90**

 logging in **81**

 main menu **82**

 message forwarding **92**

 message indicators **80**

 playing messages **82**

 receiving messages **80**

 recovering messages **84**

 saving messages **83**

 setting up **79**

 tree **94**

Voice names **41**

 creating **48, 162**

 making calls **57, 103**

 Phonebook **48**

 shortcuts **162, 163**

Voice Notes **64, 127**

 adding **129**

 deleting **130**

 labeling **129**

 locking **131**

 memory **131**

 playing **129**

 recording **128**

VoiceVolume **155**

W

Warranty **193**

Web Messaging **99**

Wireless Web **133**

Word mode, text entry **27**

Y

Your phone's numbers **23**

your Private ID **23**

