

# **SCH - T300**

**P O R T A B L E  
C E L L U L A R  
T E L E P H O N E**

## **User's Guide**

Please read this manual before operating your phone, and keep it for future reference.



## Intellectual Property

All Intellectual Property, as defined below, owned by or which is otherwise the property of Samsung or its respective suppliers relating to the SAMSUNG Phone, including but not limited to, accessories, parts, or software relating thereto (the "Phone System"), is proprietary to Samsung and protected under federal laws, state laws, and international treaty provisions. Intellectual Property includes, but is not limited to, inventions (patentable or unpatentable), patents, trade secrets, copyrights, software, computer programs, and related documentation and other works of authorship. You may not infringe or otherwise violate the rights secured by the Intellectual Property. Moreover, you agree that you will not (and will not attempt to) modify, prepare derivative works of, reverse engineer, decompile, disassemble, or otherwise attempt to create source code from the software. No title to or ownership in the Intellectual Property is transferred to you. All applicable rights of the Intellectual Property shall remain with SAMSUNG and its suppliers.

## Samsung Telecommunications America (STA), Inc.

### Headquarters:

1130 E. Arapaho Road  
Richardson, TX 75081  
Tel: 972.761.7000  
Fax: 972.761.7001

### Customer Care Center:

1601 E. Plano Parkway, Suite 150  
Plano, TX 75074  
Toll Free Tel: 1.888.987.HELP (4357)  
Fax: 972.761.7501

Internet Address: <http://www.samsungusa.com>

©2000 Samsung Telecommunications America, Inc. All rights reserved. No reproduction in whole or in part allowed without prior written approval. Samsung Telecommunications America, Inc. is a trademark of Samsung Electronics Corporation, Ltd.

Licensed by Qualcomm Incorporated under one or more of the following patents: U.S. Patent No. 4,901,307; 5,056,109; 5,099,204; 5,101,501; 5,103,459; 5,107,225; 5,109,390.

Openwave<sup>®</sup> is a registered Trademark of Openwave, Inc.

RSA<sup>®</sup> is a registered Trademark RSA Security, Inc.

## **DISCLAIMER OF WARRANTIES; EXCLUSION OF LIABILITY**

EXCEPT AS SET FORTH IN THE EXPRESS WARRANTY CONTAINED ON THE WARRANTY PAGE ENCLOSED WITH THE PRODUCT, THE PURCHASER TAKES THE PRODUCT "AS IS", AND SAMSUNG MAKES NO EXPRESS OR IMPLIED WARRANTY OF ANY KIND WHATSOEVER WITH RESPECT TO THE PRODUCT, INCLUDING BUT NOT LIMITED TO THE MERCHANTABILITY OF THE PRODUCT OR ITS FITNESS FOR ANY PARTICULAR PURPOSE OR USE; THE DESIGN, CONDITION OR QUALITY OF THE PRODUCT; THE PERFORMANCE OF THE PRODUCT; THE WORKMANSHIP OF THE PRODUCT OR THE COMPONENTS CONTAINED THEREIN; OR COMPLIANCE OF THE PRODUCT WITH THE REQUIREMENTS OF ANY LAW, RULE, SPECIFICATION OR CONTRACT PERTAINING THERETO. NOTHING CONTAINED IN THE INSTRUCTION MANUAL SHALL BE CONSTRUED TO CREATE AN EXPRESS OR IMPLIED WARRANTY OF ANY KIND WHATSOEVER WITH RESPECT TO THE PRODUCT. IN ADDITION, SAMSUNG SHALL NOT BE LIABLE FOR ANY DAMAGES OF ANY KIND RESULTING FROM THE PURCHASE OR USE OF THE PRODUCT OR ARISING FROM THE BREACH OF THE EXPRESS WARRANTY, INCLUDING INCIDENTAL, SPECIAL OR CONSEQUENTIAL DAMAGES, OR LOSS OF ANTICIPATED PROFITS OR BENEFITS.

# Introduction To Your Samsung T300 Series Phone

Congratulations on the purchase of your Samsung T300 Series Phone. Using the latest digital technology, the Samsung T300 Series Phone operates similar to other wireless phones, while providing superior resonance and tone quality.

Your Samsung T300 Tri-Mode phone is packed with productive features that are easy to use. Here are some of them:

- ◆ Operates in 1900 MHz digital CDMA, 800 MHz digital CDMA, and 800 MHz analog networks.
- ◆ Voice Dialing – 20 Locations
- ◆ Answer or hang up calls just by opening and closing the flip on the phone.
- ◆ User friendly display with dedicated icons for signal strength, service, network, messages, vibrator, and battery
- ◆ 9 Ring Types, 24 Melody Tones, 10 downloadable ring tones via PC Link Kit, and Vibrator Alert
- ◆ Distinctive ringer types for voice, message, and alarm calls
- ◆ Distinctive ringer volumes for voice, message, and alarm calls
- ◆ Phone Book Memory – 500 Locations
- ◆ Call Logs – 10 Locations each for outgoing, incoming, and missed calls. These 30 numbers are all easy to redial.
- ◆ 2 way Short Message Services (SMS) and Voicemail notification
- ◆ Internet MiniBrowser
- ◆ Pause Dialing for tele-services
- ◆ Fast Ringer Mute during Incoming Call
- ◆ Alarm with three programmable alarms
- ◆ Last number redial – last 10 Numbers
- ◆ One-touch Turbo dialing – 9 Locations
- ◆ Two-touch Turbo dialing – 90 Locations
- ◆ Three-Touch Turbo dialing - 401 Locations
- ◆ Easily mute the microphone during conversation
- ◆ Security features including Call Restriction, Secret Number capability, and Lock mode
- ◆ Fax and Data capability
- ◆ Easily change from English to French user interface

## How To Use This Manual

This user guide explains your Samsung T300 phone operations through easy-to-follow instructions and illustrations. Check out “Getting to know your phone” on page 21 to get started understanding the functions of your phone. You’ll find much of what you need to know about using your new Samsung T300 Series Phone right here.

We’ve included some important safety and usage information that you should know before using your phone. You’ll find this information in “Usage guidelines: all about performance and safety” on page 152.

If you still have questions, we’ll be happy to answer them. Just call our Samsung Customer Care Center toll-free at 1.888.987.HELP (4357).

We hope you enjoy using your new Samsung T300 Series Phone, and thanks for choosing Samsung.



# Table of Contents

<b>Your Consumer Package .....</b>	<b>19</b>
<b>Front View of the Samsung T300 .....</b>	<b>20</b>
<b>Getting to know your phone .....</b>	<b>21</b>
Antenna.....	21
Backlight Features.....	21
CLR (Clear) Key: .....	21
Display Screen .....	21
End (power On/Off Key) .....	22
Front Flip .....	22
Headset Connector.....	22
Internet/Web Button.....	22
LED Indicator.....	23
Menu Key.....	23
Microphone.....	23
Numeric Key Functions.....	23
Receiver.....	23
Send Key .....	23
OK/Navigation Key .....	23
Voice Memo Button.....	24
Volume/Scroll Buttons .....	24
Interface (IF) Adapter.....	24
<b>Getting Started.....</b>	<b>26</b>
Getting Connected .....	26
Turning your Phone On.....	26
Turning your Phone Off.....	27

<b>List of Menu Functions .....</b>	<b>28</b>
<b>Using your Phone's Menus .....</b>	<b>33</b>
Accessing Menus by Scrolling .....	33
Returning to the Previous Menu .....	34
Accessing Menus by using their Short Cut Number .....	34
<b>Your phone's modes.....</b>	<b>35</b>
Lock Mode.....	35
Power Save Mode.....	35
Standby Mode .....	35
Conversation/Talk Mode .....	36
Silent Mode.....	36
<b>The Top Line of the Display Screen .....</b>	<b>37</b>
<b>Using the Battery .....</b>	<b>39</b>
Installing the battery .....	39
Removing the Battery .....	40
Charging the Battery.....	40
Low Battery Indicator.....	41
The Empty Battery Icon .....	41
Charging with a Travel Charger .....	41
<b>Caring for the Battery .....</b>	<b>43</b>
Protecting your battery.....	43
Disposal of Lithium Ion batteries .....	43
<b>Calls .....</b>	<b>44</b>
Outgoing.....	44
Incoming .....	44
Missed .....	45
Caller ID .....	45

Three Way Calling .....	46
Erase logs .....	47
Keeping track of call logs .....	47
Reviewing outgoing, incoming, or missed calls .....	48
Air Time .....	49
Last Call .....	49
Total .....	50
Erase Total .....	51
Lifetime .....	52

## **Phone Book ..... 53**

Answering a Call.....	54
Find Name.....	55
Add Entry.....	56
Assigning a Specific Memory Address.....	57
Pause Dialing.....	58
Storing Pauses in a Phone Book Entry.....	58
Pause dialing from a stored phone book entry.....	59
Manual pause dialing .....	60
Editing phone book numbers.....	60
Prepending a phone Number .....	61
Erasing phone book entries .....	62
Erasing the phone book.....	62
Adding a name ringer.....	63
E-mail address .....	63
Finding an Entry.....	64
Relation Search.....	65
Secret phone book numbers .....	65
To add a new phone number to the Phone Book.....	65
Setting speed dial .....	66
Storing phone numbers at the end of a call .....	67

Shortcuts to Storing Phone Numbers.....	67
<b>Dialing numbers from the phone book .....</b>	<b>68</b>
Shortcuts to Memory Dialing.....	68
<b>Web/MiniBrowser .....</b>	<b>70</b>
Launching the Minibrowser .....	70
Exiting the Web/Minibrowser .....	71
The MiniBrowser Start and End Prompts .....	71
The MiniBrowser Soft Keys.....	72
Navigating the Web.....	73
How the Keys Work in the MiniBrowser .....	74
Entering Text, Numbers, or Symbols .....	75
Alphabetical Text Entry .....	76
Number Entry .....	76
Symbol Entry.....	77
Word or T9® Text Entry.....	78
<b>Scheduler .....</b>	<b>79</b>
Today.....	79
How to schedule an event: .....	79
View Month.....	80
How to view an event: .....	81
Calendar.....	82
Date.....	83
Jump to date.....	83
Using jump to date.....	83
To Do List .....	84
How to create a to do list.....	84
To view, edit, add, or erase to do list items.....	84
Countdown .....	85
Creating a Countdown item.....	85

Adding, editing, and erasing a countdown item .....	86
World Time.....	87
Checking the Current Time in Another City or Country .....	87
Calculate .....	87
Performing a calculation.....	87
Alarm .....	89
Alarm set.....	89
To edit a programmed alarm .....	89

## **Sounds..... 90**

Ringer Options.....	90
Adjusting Ringer Volume (Quickly) .....	90
Adjusting Voice Volume during a Call.....	90
Ringer Volume .....	90
Ringer Type.....	91
Voice Calls .....	92
Messages.....	92
Browser MSG .....	94
Viewing Browser Messages.....	94
Key Beep .....	94
Alerts .....	94
Minute beep.....	95
Service .....	95
Connect.....	96
Disconnect.....	96
Fade.....	97
Network Alert.....	98
Voice Volume.....	98
Roam Ringer.....	99
Power On/Off.....	100

## **Display ..... 101**

Display Options.....	101
Backlight .....	101
Banner.....	102
Animation .....	103
My Phone Number .....	104
To display my phone number: .....	104
To view your phone number during a conversation: .....	105
Language .....	105
Set Time.....	106
Auto Hyphen .....	106
LCD Contrast.....	107
Version .....	107
<b>Voice dial .....</b>	<b>108</b>
Voice Dialing .....	108
Tips on Recording Names .....	108
Record.....	109
Play/Erase .....	110
To play voice dialing entries: .....	110
To erase all voice dialing entries:.....	110
Set Active .....	111
Training.....	111
Undo Train .....	112
<b>Voice memo.....</b>	<b>113</b>
Voice Memo .....	113
Play/Erase.....	114
<b>Call Answer .....</b>	<b>115</b>
On/Off.....	115
Default Greeting.....	116

Call Screen.....	116
Wait Time.....	117
Inbox.....	118
<b>Games.....</b>	<b>119</b>
Game Menu.....	119
Push Push.....	119
Object.....	119
Key Commands.....	120
Fly Ribon.....	120
Object.....	120
Puzzle World.....	121
Object.....	121
Spider Hunter.....	122
Object.....	122
<b>Setup.....</b>	<b>123</b>
Auto Retry.....	123
Auto Answer.....	124
Answer Mode.....	125
Tone Length.....	125
Network.....	126
Data/Fax.....	126
Receiving a fax.....	128
Changing your phone back to voice calling.....	129
Ending a fax or data call.....	129
Sending a fax or data file.....	129
<b>Mail Kit.....</b>	<b>130</b>
Mobile Originating (MO) SMS Text Messaging.....	130
Creating a New SMS Message.....	130
Multiple Addressing.....	133

Options Menu.....	133
Replying to a Message.....	134
Viewing Messages.....	135
New Messages.....	135
Inbox.....	137
Receiving a message in standby mode .....	137
Receiving a message while on a call .....	137
Receiving a Message in Standby Mode .....	137
Reviewing numeric pages, text messages, and browser messages ..	138
Outbox.....	139
Sent.....	139
Stored.....	139
Message options .....	139
Message Ringing .....	140
Message Time .....	140
Creating a New Message:.....	141
Message Memory Capacity .....	142
Messages and Lock Mode .....	142
Voicemail.....	142
Listening to your Messages .....	143

## **Security ..... 144**

Security Features.....	144
Lock Mode.....	144
Locking the phone.....	144
Unlocking the phone .....	145
Dialing in lock mode .....	145
To place an outgoing call in lock mode: .....	145
Restrict .....	146
Lock Code.....	146
Emergency #.....	147

Storing numbers .....	148
Send PIN .....	148
Clearing the Memory.....	149
Resetting the Phone.....	150

**InUse Menu ..... 151**

**Usage guidelines:  
all about performance and safety ..... 152**

Understanding Signal Strength .....	152
Understanding the Power Save Mode .....	152
Understanding how Your Phone Operates .....	152
Specifications are Subject to Change .....	152
Exposure To Radio Frequency Signals.....	153
Antenna Care.....	153
Phone Operation.....	154
Tips on Efficient Operation.....	154
Operating a Motor Vehicle .....	154
Electronic Devices.....	154
Pacemakers .....	154
Other Medical Devices .....	155
Posted Facilities .....	155
Aircraft.....	155
Blasting Areas .....	156
Potentially Explosive Atmospheres.....	156
For Vehicles Equipped with an Air bag.....	156
Storing your phone .....	156
Cautions.....	157
Voice Memo.....	157
Information to User.....	158

<b>Your Phone as a Network Device .....</b>	<b>159</b>
<b>Acknowledging Special Precautions and the FCC and Industry Canada Notice .....</b>	<b>160</b>
Cautions.....	160
FCC and Industry Canada Notice.....	160
Information to User .....	160
Samsung Phone and Battery Specifications.....	161
Samsung Phone with Standard Battery .....	161
Samsung T-300 Phone with Extended Battery.....	162
Owner's Record.....	162
User Guide Proprietary Notice.....	162
<b>Limited Warranty.....</b>	<b>163</b>
<b>Index.....</b>	<b>167</b>
<b>Quick Reference Guide .....</b>	<b>173</b>
Features .....	173
Basic Operation .....	174



# Your Consumer Package

Your consumer package contains the following items:

- ◆ Samsung SCH-T300 phone with hand strap
- ◆ Samsung standard Li-ion battery
- ◆ Samsung travel charger
- ◆ User guide

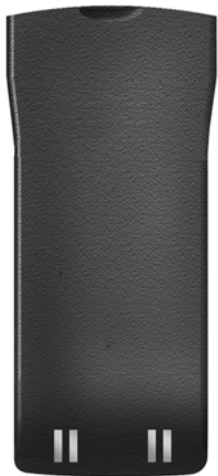

# Front View of the Samsung T300



# Getting to know your phone

## Antenna



A device for transmitting or receiving signals. An antenna makes the call sound clearer when fully extended. Use only in the normal position and do not touch the antenna excessively when the phone is active.

## Backlight Features

Your keypad has backlighting for easy visibility. For further information on this feature see “Backlight” on page 101.

## CLR (Clear) Key:

The clear key is used to erase numbers or characters that have been entered incorrectly, or it can be used to return to a previous screen in the menu.

- ◆ If an incorrect number or character has been entered on the display screen, press the CLR key once briefly, to erase it.
- ◆ To erase all digits or characters from the display screen, press this key for one second.
- ◆ To back up one menu level, press  once, briefly.
- ◆ To return to standby mode from any menu, press .

## Display Screen

The display has two areas, an upper line of stationary icons, and the lower text and graphic area.

- ◆ The top line of icons shown on the LCD (liquid crystal display), are displayed according to the phone's operating mode. For further information see “Turning your Phone On” on page 26.
- ◆ The lower area of the LCD displays the InUse information, for example (if available), the calling party's name and number, the call timer, mute and call waiting, as well as menus, sub menus etc.

## End (power On/Off Key)

This key is utilized several ways:

- ◆ Press and hold to turn on your phone.
- ◆ Press and hold to turn off your phone.
- ◆ Press once to disconnect a call or to return to standby mode and cancel your input.

## Front Flip

Closing your phone's flip ends a call. There are several options that can be set when you open the phone's flip:

- ◆ Answer an incoming call: To set this option, and for further information see "Answer Mode" on page 125
- ◆ Voice dial an individual: To set this option, and for further information see "Voice Dialing" on page 108.
- ◆ Control the backlight: To set this option, and for further information see "Backlight" on page 101.

## Headset Connector

This is where the optional headset connects to the phone. The headset includes an earpiece and microphone in a convenient, lightweight unit so you can converse without using your hands.

## Internet/Web Button

This button allows you to access instant information such as stock quotes and weather via the Internet. Browsing the web via the phone is not the same as using your computer. Site providers have selected only the critical aspects of their site to present to wireless phone users, and have removed most graphics.

## LED Indicator

Flashes to indicate an incoming call or message. When the phone is closed and the ringer is set to off, the LED indicator will notify you that there is an incoming call or message.

- ◆ Lights up when you turn on the phone.

## Menu Key

Press to enter the menu facility.

## Microphone

A typical microphone used for conversation, but this microphone also accepts voice commands for voice dialing and voice memos.

## Numeric Key Functions

Numeric keys can be used to enter text, numbers and special characters.

## Receiver

Is for listening to voice conversations.

## Send Key

This key performs several useful functions:

- ◆ Press to answer calls.
- ◆ Dial a number and press to connect.
- ◆ Press it twice in when in standby mode to redial the last outgoing number.

## OK/Navigation Key

When in the menu facility this key allows you to scroll through the menu options using your thumb. It also stores information that you have entered and acts as an “OK” button when you press it in the

center. When in standby mode, it functions as a hot key when it is pressed or clicked in any of the four directions.

Pushing the OK/Navigation key to the left or right displays different screen savers loaded into the phone. Pushing it up/down displays the Phone Book.

## Voice Memo Button

Located on the left side of the phone.

- ◆ Press and hold this button to record up to 240 seconds of audio.
- ◆ A total of four minutes of audio can be recorded. These voice memos can be stored indefinitely or erased as desired.
- ◆ From the menu in standby mode, press the voice memo button briefly to view the voice memo menu.
- ◆ Can record audio during a conversation.

## Volume/Scroll Buttons

These buttons (one up/one down) on the side of the phone are used to set audio volume levels.

Press the volume/scroll buttons to:

- ◆ Scroll up/down or through the menu functions.
- ◆ Adjust the headphone volume during conversation.
- ◆ Adjust the ringer (8 levels) volume in standby mode. (No bars indicate that the ringer is turned off.)
- ◆ Turn on/off Vibrate mode.
- ◆ Mute ringer during an incoming call.

## Interface (IF) Adapter

Located at the bottom of the phone.

- ◆ Before using, gently pry the cover from the phone to expose the IF adapter.

- ◆ This plug is used to connect additional phone accessories such as the travel charger and data cable.

# Getting Started

## Getting Connected



You must contact your service provider to obtain service for your Samsung T300 phone. It is suggested that you read this user guide to fully understand the features that your phone supports.

## Turning your Phone On

To turn your phone on, open the phone's flip cover and press the **END/0** key. Hold down the key for a few seconds to turn the phone on:

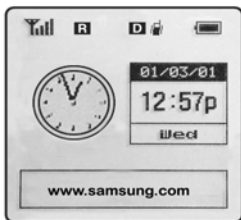
The service light in the top left of the phone flashes, and an alert sounds. The phone begins searching for a network signal. When a signal is found, the date, time and day is displayed, and the phone enters standby mode. You can now send and receive calls. The standby mode screen is shown below:



- ◆ Signal strength icon 
- ◆ Battery strength icon 
- ◆ Time and date.
- ◆ Day
- ◆ Roaming **R**
- ◆ Digital Mode **D**
- ◆ Analog Mode **A**

**Note:** If the phone is out-of-service the  icon displays. If this happens you cannot place or receive calls. You can try later when service becomes available. For further information see “The Top Line of the Display Screen” on page 37

## Turning your Phone Off

To turn your phone off, press and hold the  key for more than 2 seconds. Notice that when the phone is turned off, both the display screen and backlight are off.

**Note:** If your phone is on and the  key is selected for less than one second, the phone will not turn off. This feature stops your phone from being turned off accidentally.

# List of Menu Functions

This list displays the menu structure and indicates the number assigned to each option.

## 1. Calls

- 1: Outgoing
- 2: Incoming
- 3: Missed
- 4: Erase Log
  - 1: Outgoing
  - 2: Incoming
  - 3: Missed
  - 4: All
- 5: Air Time
  - 1: Last Call
  - 2: Total
  - 3: Erase Total
  - 4: Lifetime

## 2. Phone Book

- 1: Find Name
- 2: Add Entry
- 3: Find Entry
- 4: RelationSrch
- 5: Add email

## 3. Web

- 1: Launch Web
- 2: Prompt

## 4. Scheduler

- 1: Today
- 2: View Month
- 3: Date
- 4: To Do List
- 5: Countdown
- 6: World Time
- 7: Calculator
- 8: Alarm Set

## 5. Sounds

- 1: Ringer Vol
  - 1: Calls
  - 2: Messages
  - 3: Alarm
  
- 2: Ringer Type
  - 1: Voice Calls
  - 2: Messages
    - 1: Voice Mail
    - 2: Text
    - 3: Web MSG
  
  - 3: Alarm
  - 4: Data/Fax In
  - 5: Schedule
  
- 3: Key Beep
- 4: Alerts
  - 1: Minute Beep
  - 2: Service
  - 3: Connect
  - 4: Disconnect
  - 5: Fade
  - 6: Network
  
- 5: Voice Volume
- 6: Roam Ringer
- 7: Power On/Off

## 6. Display

- 1: Backlight
- 2: Banner
- 3: Animation
  - 1: Power On
  - 2: Power Off
  - 3: Idle 1
  - 4: Idle 2
  
- 4: My Phone #
- 5: Language
- 6: Set Time
- 7: Auto Hyphen
- 8: LCD Contrast
- 9: Version

## 7. Voice Dial

- 1: Record
- 2: Play/Erase
- 3: Set Active
- 4: Training
- 5: Undo Train

## 8. Voice Record

- 1: Voice Memo
  - 1: Record
  - 2: Play/Erase
  
- 2: Call Answer
  - 1: On/Off
  - 2: Config
  
  - 1: Screening
  - 2: Wait Time
  
- 3: Inbox

## 9. Games

- 1: Push Push
- 2: Fly Ribon
- 3: Puzzle World
- 4: Spider Hunter

## \*. Setup

- 1: Auto Retry
- 2: Auto Answer
- 3: Answer Mode
- 4: Tone Length
- 5: Network
- 6: Data/Fax

## 0. Mail Kit

- 1: New Message
- 2: Inbox
  - 1: Voice
  - 2: Text
  - 3: Web
- 3: Outbox
  - 1: Sent
  - 2: Stored
- 4: Delivery
- 5: MSG Setup
  - 1: General
    - 1: Scroll Timer
    - 2: Msg. Remind
- 2: New Message
  - 1: Call Back #
  - 2: Save Message
  - 3: Entry Method
  - 4: Delivery Ack
  - 5: Canned Msg.
- 3: Erase
  - 1: Voice Notif.
  - 2: Received
  - 3: Sent
  - 4: Stored
  - 5: All

## #. Security

- 1: Lock Mode
- 2: Restrict
- 3: Lock Code
- 4: Emergency #
- 5: Send Pin
- 6: Clear MEM
- 7: Reset Phone

## InUse Menu

- 1: Mute/Quit
- 2: Calls
  - 1: Outgoing
  - 2: Incoming
  - 3: Missed
  - 4: Erase Log
  - 1: Outgoing
  - 2: Incoming
  - 3: Missed
  - 4: All
  - 5: Air Time
    - 1: Last Call
    - 2: Total
    - 3: Erase Total
    - 4: Lifetime
- 3: PhoneBook
  - 1: Find Name
  - 2: Add Entry
  - 3: Find Entry
  - 4: RelationSrch
  - 5: Add email
- 4: Silent/Quit
- 5: Send Tel#
- 6: My Phone#
- 7: Version

# Using your Phone's Menus

The phone offers a range of functions that allow you to tailor the phone to your personal requirements. These functions are arranged in menus and submenus.

The menus and submenus can be accessed by scrolling or using shortcuts.

## Accessing Menus by Scrolling

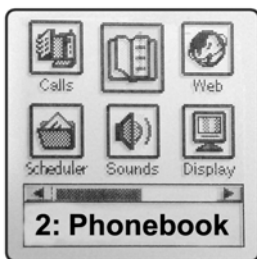

Menu items are numbered and can be accessed by scrolling then selecting that option. For example:



1. Press the **MENU** key in standby mode to access the menu.



2. To enter the Sounds menu, using your thumb, slide , until the Sounds menu displays.

3. Press the  in the center to select this option.

4. Again, using your thumb scroll to Alerts, using the same key.
5. Press the  key in the center to enter the Alerts menu.
6. Scroll to Connect, using the same key.
7. Press the  key in the center to enter the Connect menu.
8. Use your thumb on the  key to select the desired setting.

9. Press the  key in the center to confirm your selection.
10. Your phone saves this setting and returns to standby mode.

## Returning to the Previous Menu

- ◆ To return to the previous menu, press the  key.
- ◆ Select the  key to exit the menu without saving the setting.



## Accessing Menus by using their Short Cut Number

The menu items are numbered and can be accessed by using their shortcut numbers.

1. In standby mode, press the  key to access the menu options.
2. Key in the first digit of the required 'shortcut' number shown on the display, repeat this action for each digit displayed as menus are displayed.

For example:





Setting the Connect tone to 'on'.

1. Press the  key for Sounds.
2. Press the  key for Alerts.
3. Press the  key for Connect.

**Note:** For further details see “List of Menu Functions” on page 28 for the numbers assigned to each menu item.

# Your phone's modes

## Lock Mode



When you lock your phone using the Lock mode menu option, phone use becomes restricted. You can receive messages and calls, but you cannot make an outgoing call until the phone is unlocked. To unlock the phone, press , , , or  and enter the lock code. The phone will return to standby mode.



## Power Save Mode

Your phone comes with a Power Save feature that automatically activates if your phone is unable to find a signal after 15 minutes of searching. While this feature is active, the phone's battery charge is conserved. The phone automatically rechecks periodically for a signal. To manually force the phone to recheck for a signal, press any key. A message on the display screen will inform you when your phone is operating in the Power Save mode.

## Standby Mode

Standby is the fundamental state of your phone. The phone goes into standby mode soon after you turn it on, or if your phone is on, whenever you press the  key.

While in standby mode, you can enter a phone number, press the  key to dial it, or press the  key in the center to save it in the Phone Book.

Press the  key at any time to return to the standby mode, but be careful; if you are on a call when you press the  key, you will return to standby mode and disconnect the call.

## Conversation/Talk Mode

You can send and answer calls only when your phone is turned on. During a call, the phone is in conversation or talk mode. While you are in this mode, pressing  gives you a list of options referred to as 'InUse Options'. See "InUse Menu" on page 151.

## Silent Mode

The phone can be set to a silent mode with a press of a button. The silent mode disables all sound on the phone. This feature is best used in situations where the phone might disturb others, such as a meeting, library, etc.

1. To enable silent mode, press and hold  .
2. A message is displayed on the screen that indicates the phone is in Silent Mode.

# The Top Line of the Display Screen

Display indicators (or icons) appear across the top of your phone's display screen. The signal strength and battery strength icons are always displayed, but the other icons appear based on your phone's operating mode.



**Signal strength:** This icon always appears when your phone is on, and shows your current signal strength. The more lines displayed, the better the signal strength. Four lines indicate maximum strength.



**Service indicator:** This icon indicates a call is in progress. If there is trouble with signal strength, this indicator will have a diagonal line through it.



**No service indicator:** This icon indicates your phone cannot find a signal because you are outside a service area. When displayed, you cannot send or receive calls. Wait for a better signal or move into an open area to regain service.

**Note:** The no service indicator always displays when you turn on your phone. When service is located, the indicator disappears.



**Roaming:** This icon displays when the phone is outside your carrier's area and receiving service from another carrier's network.

If you are:

- ◆ In your home service area, this indicator does not display.
- ◆ In a preferred analog or digital network area (where your service provider has a network agreement in place), this indicator is on, but not flashing.
- ◆ In an analog or digital area that is not covered by your phone's service provider, this indicator is on.



**New Message:** These icons appear when a new voice, text or page message, or net alert is received.



**Digital mode:** This icon indicates your phone is operating in digital mode. Your phone has some features that work only in a digital service area; these services include the Web Browser and certain other message(s) services.



**Analog mode:** This icon indicates that your phone is operating in analog mode.



**Vibrating mode:** This icon indicates that an incoming call will make the phone vibrate rather than ring. This feature is used for situations where your normal ringer may disturb others, or for "loud" situations where a ringer cannot be heard.



**Battery strength:** This icon is displayed when your phone is active. It displays your battery's current charge level. The more bars, the greater the charge. When the battery becomes very low, an empty battery icon displays and the phone flashes an alert; this indicates that your phone is about to turn itself off.

# Using the Battery

**Note:** Your phone comes packaged with a partially charged, rechargeable standard Li-ion battery. The phone can be used while the battery is charging, but must be fully charged the first time you use your phone otherwise the battery could be damaged.

## Installing the battery

The battery attaches to the phone very easily:

1. Insert the contact end on the bottom of the battery into the slots on the bottom of the phone.
2. Press the battery down until you hear it click into place.

## Removing the Battery

To remove the battery from your phone:

1. Turn the phone off (by pressing and holding **END/⓪** until the closing animation sequence begins.)
2. Push the catch button up on the top of the battery on the back side of the phone. (see illustration). The battery will easily lift out or fall away from the phone.

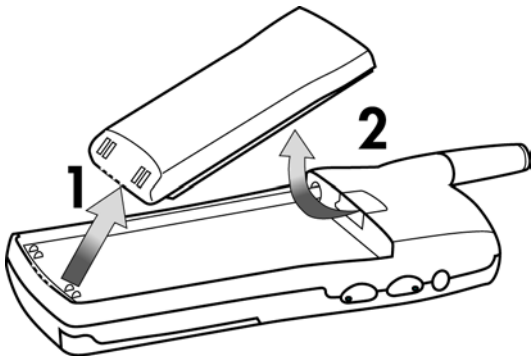

## Charging the Battery

**Note:** A standard battery is provided with your phone. The battery must be fully charged before using your phone for the first time. The phone can be used while the battery is charging.

Your phone is powered by a rechargeable Li-ion battery. Only use Samsung approved chargers and batteries. These chargers are designed to maximize battery life. Using other chargers voids your warranty and may cause damage.

## Low Battery Indicator

You can tell whether or not your battery needs to be recharged by checking the  indicator (it's located in the upper-right corner of the display). The presence of all three bars indicates a full charge, two bars indicates a medium charge, and one bar indicates a minimum charge. No bars (the battery icon is empty) indicates the battery no longer has any charge and must be recharged.

## The Empty Battery Icon

Two to three minutes before the battery charge level gets too low to operate the phone, the battery sensor will let you know by blinking an empty battery icon (  ), and sounding a tone. If you continue to operate the phone without charging the battery, the phone will turn off automatically. If this happens, your wireless call will be ended. But if you plug into a charging device, you can continue your call. Be sure to monitor the battery strength icon and make sure your battery is sufficiently charged.

## Charging with a Travel Charger

The travel charger allows you to charge your phone's battery from any standard 110VAC wall outlet. Also, using the travel charger allows you to make a phone call while the battery is charging. The travel charger will fully charge an "empty" standard battery in about three hours, and an "empty" extended battery in about four hours.

Follow these steps:

1. With the battery connected to the phone, connect the travel charger to the accessory connector on the bottom of the phone.
2. Connect the charger to a standard 110 AC wall outlet. The battery begins charging.

3. The LED on the travel charger indicates the status of the battery charge.
  - ◆ Red indicates that the battery is charging.
  - ◆ Green indicates that the battery is fully charged.
  - ◆ Yellow indicates that the battery is operating at a temperature that is too high or too low, or that the charger is not plugged in correctly. Please check the charger and battery.
4. The travel charger continues charging the battery even when you are making outgoing calls.

**Note:** The battery charges faster when the phone is off.

# Caring for the Battery

## Protecting your battery

The guidelines listed below help you get the most out of your battery's performance.

- ◆ Use only Samsung approved batteries and chargers. Samsung chargers are designed to maximize battery life. Using other manufacturers batteries or chargers voids your warranty and may cause damage.
- ◆ In order to avoid damage, charge the battery only in temperatures that range from 32° F to 113° F (0° C to 45° C).
- ◆ Don't use the battery charger in direct sunlight or in high humidity areas, such as a bathroom.
- ◆ Never dispose of the battery by incineration.
- ◆ Keep the metal contacts on top of the battery clean.
- ◆ Don't attempt to disassemble or short-circuit the battery.
- ◆ The battery may need recharging if it has not been used for a long period of time.
- ◆ Replace the battery when it no longer holds an acceptable charge.
- ◆ Don't store the battery in high temperature areas for long periods of time. It's best to follow these storage rules:

Less than one month:  
4° F to 140° F (-20° C to 60° C).

More than one month:  
4° F to 113° F (-20° C to 45° C).

## Disposal of Lithium Ion batteries



For safe disposal options of your Lithium Ion batteries, contact your nearest Samsung Authorized Service Center.

**Note:** Dispose of your battery properly. In some areas, the disposal of batteries in household or business trash may be prohibited.

# Calls

## Outgoing

To place a call:

1. Press  to power on your phone.
2. Enter the phone number you wish to call (up to 32 digits) by pressing the digit keys. The phone number is displayed from left to right.
3. Press the  key. The phone calls the number entered.

## Incoming

Your phone signals an incoming call or message in the following ways:

- ◆ The backlight illuminates.
- ◆ The red LED on the top of the handset flashes.
- ◆ The ringer sounds (unless you have set the ringer to Vibrate or Off).

Incoming call notification continues until one of the following events occurs:

- ◆ You answer the call.
- ◆ The calling party ends the call.
- ◆ The call is sent to Voicemail.

Your phone provides the following voice call notification features.



- ◆ Nine ring volume settings including Vibrate, Off, and 1-Beep.
- ◆ Nine unique ring types, twenty four melody tones, and ten downloadable ring tones. (see “Ringer Type” on page 91).
- ◆ Name display with Caller ID.
- ◆ Automatic storage of an incoming call’s information in the Call directory (the last 10 calls you answered are stored in the Incoming

directory and the last 10 calls you missed are stored in the Missed directory).

## Missed

Your phone keeps a list of calls that were not answered when the phone is on and service is available. The phone indicates a missed call by displaying a text notification on the screen. Additionally, if caller information is available, a Missed entry is created, and the screen displays the phone number of the most recent missed call.

Your phone gives you two very convenient options when you have missed a call:

- ◆ Press  to call the displayed number.
- ◆ Pressing  in the center saves the number in the Phone Book.



To view a list of your missed calls, see “Reviewing outgoing, incoming, or missed calls” on page 48.

- ◆ Press  to clear the “Missed Call” message from the display.

## Caller ID

This feature allows you to see who is calling you by displaying the callers number when the phone rings. If the callers name and number are stored in the phone book, the name is also displayed. You can also block your number from being displayed on another phone by enabling the call block feature.

To activate call block:

1. Press   
2. Enter the phone number and press 

**Note:** To block your number permanently, contact your service provider.

## Three Way Calling

Three-way calling allows you to talk with two different people at the same time. When you use this feature, normal airtime rates apply for each call. If during the call, one of the callers hangs up, you are still connected to the other caller. If you hang up, the other two parties are automatically disconnected.







**Note:** Contact your service provider to make sure three-way calling is available in your area.

To three way call:

1. Place a call normally using the phone. Dial the number of the first person and press **SEND**.
2. When the first party has been connected. Ask them to wait and press **SEND**. The caller is placed on hold.
3. Dial the second parties phone number and press **SEND**.
4. When the second party is connected, press **SEND** to connect all parties together.

## Erase logs

You can erase any of the three lists (Outgoing, Incoming or Missed calls) or you can easily erase all three lists at once. Here is an example:

1. Press  to display the menu.
2. Press  for the Call menu.
3. Press  for Erase Logs.
4. Press  for All.
5. Pressing  in the center erases all your logs.
6. Pressing  cancels the action if you do not wish to erase all your logs.

## Keeping track of call logs



Your phone saves a log of call activity and permits you to easily return calls.

Your phone retains the following call logs in memory:

- ◆ Outgoing - the last 10 calls dialed.
- ◆ Incoming - the last 10 incoming calls.
- ◆ Missed - the last 10 calls missed.









Each Call Log contains the name and phone number (if available).

In addition to the Incoming, Outgoing, and Missed calls lists, your phone maintains an air time log. For further information see “Air Time” on page 49.

You can quickly access your last 10 incoming, outgoing, and missed calls from standby mode by pressing  . Use  to select the desired call log.

## Reviewing outgoing, incoming, or missed calls



When a call log is displayed, press the appropriate number to be automatically connected.

1. Press  to display the menu.
2. Press  for Calls.
  - ◆ Press the associated digit key to select an option:
    - ◆ Press  for Outgoing calls.
    - ◆ Press  for Incoming calls.
    - ◆ Press  for Missed calls.
3. When the list of calls displays, press the scroll key to scan the logs. If there is a Phone Book match, the name displays. If there is no Phone Book match, only the phone number displays.
4. When a log is highlighted you can press:
  - ◆  to be connected to that party.
  - ◆ When you are viewing this information you can press  for more options (Talk, Save, Call Info, and Prepend the number).
5. Press  to exit the Call Logs list and return to the previous screen.

## Air Time







Your phone logs the amount of air time or talk time used for all calls.

To view the call logs:

1. Press .
2. Press  for Calls.
3. Select  for Air Time.
4. Then use the scroll key to review your options.
5. Press the desired key to be automatically connected to the option of choice.

## Last Call







Last Call allows you to view the amount of time spent on the last call made:

1. Press  to display the menu.
2. Press  for Calls.
3. Press  for Air Time.
4. Press  for Last Call. The amount of time spent on your last call displays.
5. Press  to return to the previous display screen, or press  in the center to quit.

## Total







Total air time is the amount of time the phone has been used since it was last erased. All incoming and outgoing calls are saved in the log. This feature is not intended for billing purposes.

To view or erase total air time:

1. Press  to display the menu.
2. Press  for Calls.
3. Press  for Air Time.
4. Press  for Total. The screen displays the total number of calls and the total air time for all calls since you set this total to zero (by using the “Erase Total” option).
5. Press  to return to the previous display screen, or press  in the center to quit.

## Erase Total

To erase your total air time:







1. Press  to display the menu.
2. Press  for Calls.
3. Press  for Air Time.
4. Press  to Erase Total. Press  in the center to erase the “Total” airtime measurement, or press  to cancel the operation and return to the previous display screen.

**Note:** If you choose the Erase Total option, the counter is reset to “zero” and begins counting the next time you make or receive a call.

## Lifetime

Lifetime air time is the amount of time the phone has been used since it was activated. All incoming and outgoing calls are saved in the log.

To view your total lifetime air time:

1. Press  to display the menu.
2. Press  for Calls
3. Press  for Air Time.
4. Press  for Life Time.
5. Press  to quit or  to return to the previous menu.

**Note:** You cannot erase any information created by this option.

# Phone Book

Your phone allows you store up to 500 numbers and names in the Phone Book. Each entry can have up to 8 associated phone numbers. Each entry can contain up to 32 digits including hard pauses, with an associated name of up to 12 characters. (Name entry is optional) Stored phone numbers can be categorized as one of eight categories - Voice Dial, Speed Dial, Home, Office, Mobile, Pager, Fax and No-label. The memory location can be specified for each entry. Memory locations can be marked “Secret”, preventing any unauthorized person from viewing the telephone number.

There are three pre-programmed locations in the phone book. They are:

- ◆ 211 - Non-Emergency Services
- ◆ 311 - Air & Marine Rescue
- ◆ 411 - Information Assistance

These numbers were automatically saved in these locations to allow three digit dialing. For more information on three touch dialing, see “Dialing numbers from the phone book” on page 68.

One-Touch, Two-Touch, and Three-Touch dialing makes it easy to call a phone number stored in your Phone Book. See “Shortcuts to Memory Dialing” on page 68.





## Answering a Call

When you receive a call, the phone will ring and a phone icon is displayed on the screen. If the caller can be identified, the caller's phone number (or name if pre-stored in your Phone Book is displayed. If the caller cannot be identified only the phone icon displays.

There are several ways to answer an incoming call:







- ◆ Open the flip.
- ◆ Press the Send button

Your phone is preset to answer when you press . You can easily change how your phone answers by setting the Call Answer feature as explained here:

1. Press  to display the menu.
2. Press  for Setup.
3. Press  for Auto Answer.
4. Use the scroll keys to toggle between 5 seconds 3, seconds, 1 second, and off.
5. Press  to save the setting. and you will be returned to standby mode.

## Find Name

With your phone in standby mode:







1. Press  to display the menu.
2. Press  for the Phone Book.
3. Pressing  displays the Find Name option.
4. Slide the  key up or down to scroll the phone numbers.
5. Pressing  in the center selects the number.
6. The phone display screen shows the details.
7. Press  to place the call, or enter the first few numbers of the phone number to display the speed dial number. For further information see “Setting speed dial” on page 66.
8. With a selected entry, pressing  allows you to access the following options:
  - ◆ **Talk:** Pressing Talk dials the number
  - ◆ **Add #:** Allows you to add a new entry.
  - ◆ **Edit:** Edits the phone number, name, entry or secret number.
  - ◆ **Prepend:** Allows you to prepend a number to either a feature code or area code before dialing.
  - ◆ **Erase:** Erases the number.
  - ◆ **Name Ring:** Allows you to select a unique tone to identify an incoming call by the ringer type.
  - ◆ **Email Address:** Allows you to add an e-mail address.

**Note:** Stored names display numerically by memory position.

## Add Entry

This menu permits you to store a phone number, name, location, category, relation, and ringer type in your Phone Book.

To add an entry:



1. Press  to display the menu.
2. Press  for Phone Book.
3. Press  for Add Entry.
4. The display screen prompts 'Add Entry #'.
5. Enter the phone number. (Up to 32 digits can be entered.) Press the digit keys to enter the phone number. (The number displays from left to right).
6. Press .
7. Press  to save as a New Entry.
8. A PhoneBook screen is displayed.
9. Scroll through the following options by toggling  up or down. The phone allows you to overwrite any existing information, or if nothing is displayed, you can enter information from the screen. The following fields are available:

◆ **Phone Number:** Telephone number

◆ **Name:** Associated Name.





◆ **Location:** The number allocated to the name in the list of names and numbers you created.



- ◆ **Secret:** This field advises if this number is one of your ‘secret’ numbers.
- ◆ **Category:** This is the category label associated with the entry. For example; Voice Dial, Speed Dial, Home, Office, Mobile, Pager, or Fax.
- ◆ **Relation:** Pressing the scroll key displays both the number and the name associated with it.
- ◆ **Ringtype:** Informs you if the Ring Type is Active or Inactive.

10. Press  on any selected field to enter information.
11. Press  to save the information.
12. When finished editing all fields, press  to save and exit the phonebook.

## Assigning a Specific Memory Address

It may become necessary to assign a specific memory address for a phone number entered into the phone book. Memory addresses are available from 1-500. To assign a specific memory address:

1. Key in the number using the keypad.
2. Press .
3. Press  for “New Entry”.
4. Press  and enter a name for the entry.
5. Press  to save the name.
6. Press  down to highlight “Location”.

7. Press  to display the “Memory” screen.
8. Enter the desired memory location using the keypad.
9. Press  to save and exit.

## Pause Dialing

When you call automated systems, you are usually required to enter a password or account number. Instead of manually entering the numbers each time, the numbers can be stored in your Phone Book separated by special characters called pauses.

There are two kinds of pauses that can be entered on your phone:

- ◆ Hard pause - A hard pause stops the dialing sequence.
- ◆ Two second pause - A two second pause stops the dialing sequence for two seconds and then automatically sends the remaining digits.

Your phone has two pause dialing methods: pause dialing from the Phone Book (see “Pause dialing from a stored phone book entry” on page 59), and manual pause dialing (see “Manual pause dialing” on page 60).

**Note:** Multiple two second pauses can be entered to extend the length of a pause. For example, two consecutive two second pauses cause a total pause time of four seconds. However, keep in mind that pauses count as digits towards the 32 digit dialing maximum.

## Storing Pauses in a Phone Book Entry



To store a number in your Phone Book that contains pauses:

1. Enter the phone number you want to store.
2. Press  to display options to display the following options:

- ◆ P pause - This option is used to enter a hard pause that will stop the dialing sequence. Enter the account number or password digits after entering this pause.
  - ◆ T pause - This pause is an automatic two second delay in the dialing sequence. If numbers are entered after this pause, the dialing is suspended two seconds and then resumed with the digits entered after the pause.
  - ◆ Hyphen - This allows you to enter a hyphen between the digits in the phone number for easier viewing. This does not affect the dialing procedure.
3. Press 1, 2 or 3 to select the desired choice when entering the dialing sequence.
  4. Store the number in your Phone Book by pressing the  key and following the display prompts.

## Pause dialing from a stored phone book entry



### Pause dialing from the Phone Book:

1. If you stored the number using a two second pause(s), simply dial the number from the Phone Book.
2. If you stored the number using a hard pause(s), simply dial the number from the Phone Book and wait for the appropriate prompt from the number you are calling (credit card number, bank account number, etc.). When prompted, press  or  to send the DTMF number that follows your hard pause. "SENDING DTMF" is displayed on the screen (the transmitted tones are audible).

## Manual pause dialing

To perform manual pause dialing without first storing the number in the Phone Book, enter pauses manually using the Digit Entry menu during the dialing process.





To manually dial a number using a pause(s):





1. Enter the phone number of the service you want to call. For example, your bank's automated phone number might be an 800 number.
2. Press  to display digit dialing options.
3. Press 1, 2 or 3 to select the desired choice when entering the dialing sequence.
4. Enter the remaining digits using the keypad after the pause.
5. Press  to make the call.

## Editing phone book numbers

When a number is stored in the Phone Book, it can be easily changed by editing the information.

To change a Phone Book entry:

1. From standby mode, toggle the  button down and search for the Phone Book entry that you want to change.
2. Highlight the name and press .
3. Press the  key for Options.
4. Press  to select Edit.

5. Your Information displays. If the number has been designated as “Secret” you are prompted to enter the Lock Code. Toggle using the  key and choose from one of the following options:
  - ◆ Phone number
  - ◆ Name
  - ◆ Location
  - ◆ Secret
  - ◆ Category
  - ◆ Relation
  - ◆ Ringtype
6. Press  to edit the selected field.
7. Press  to accept or  to return to the previous menu.
8. Press  to exit.





## Prepending a phone Number

The Prepend option lets you add digits such as area codes and network feature activation codes to a phone number that is stored in your Phone Book or Call Logs.

**Note:** The prepended phone number cannot be longer than 10 digits.







To Prepend a stored phone number:



1. Press  to display the menu.
2. Press  for Phone Book.
3. Press  for Find Name.

4. Highlight the desired name and press .
5. Press  to display options.
6. Press  for Prepend.
7. The screen displays Prepending #. Use the keypad to enter the calling prefix and press  to place the call.

## Erasing phone book entries

To erase an entry in the Phone Book:

1. From standby mode, find the Phone Book entry that you wish to change by pressing    and scrolling to the name or number.
2. Press the  key to display the name or number.
3. Press the  key for options.
4. Scroll to the “Erase” option.
5. Press  to Erase. Your phone will prompt for confirmation.

Press  to confirm and erase the Phone Book entry, or press  to cancel the Erase command and return to the Phone Book Options menu.

The “Erased” notification displays together with the name, number, and location of the erased entry.

## Erasing the phone book







See “InUse Menu” on page 151

## Adding a name ringer

You can associate nine tones, 24 melodies, and 10 downloaded melodies to the numbers stored in your Phone Book. When you receive an incoming call from a number matching an entry in your Phone Book your phone will play the associated ringer to announce the call.

**Note:** If the Caller ID information was unavailable for an incoming call then the Name Ringer option will also be unavailable.





To add a Name Ringer to a Phone Book entry:

1. Press  to display the menu.
2. Press  for Phone Book.
3. Press  to find the desired name entry in the phone book.
4. Find the number to which you wish to add a Name Ringer, using one of the search methods described under “Finding an Entry” on page 64, and then press .
5. Press  to display Options.
6. Press  to scroll to Name Ring.
7. Your phone displays the current ringer setting. Use the scroll key to listen to available ringers and melodies.
8. Press  to save the selected ringer.

## E-mail address







You can add an email address entry to the phone book for text messaging. Your phone can send a message via the network to an email address.

To add an email address:

1. Press  to display the menu.
2. Press  for Phone Book.
3. Press  for Add email.
4. Enter the email address using the numeric keys.
5. Press  to accept.
6. Add the email as a New Entry.
7. Press  to save the entry.

## Finding an Entry

This option allows you to find an entry by location number

1. Press  to display the menu.
2. Press  for the Phone Book.
3. Press  for Find Entry. The Phone Book 'Look Up' screen displays.
4. Enter the memory location or toggle  down to scroll through the list of entries.
5. Press  to select the entry.
6. Press  to place a call.







## Relation Search

### Secret phone book numbers

Your phone allows you to hide a confidential number so that only a person with your phone's Lock Code can view that name and number. To make a number "Secret," see "To add a new phone number to the Phone Book" on page 65. When you have made the number "Secret," the phone does not permit anyone to view information on that particular number unless the four-digit lock code is entered.

### To add a new phone number to the Phone Book

To store phone numbers and names:





1. Enter the new phone number and press  twice.
2. Press  to edit the name field.
3. Enter the name using the keypad and press  to save.
4. Toggle to the Relation field and press .
5. Toggle through the options using . The following choices are available:
  - ◆ No Group
  - ◆ VIP
  - ◆ Colleague
  - ◆ Family
  - ◆ Friend
6. Select the desired choice and press  to save.

7. Press  to save and exit.

## Setting speed dial

For each name entered in the Phone Book, you can assign a Speed Dial number.



To assign the number:

1. Open the desired phone book entry.
2. Toggle  and select the Category field.
3. Press  to edit. The following options are available:
  - ◆ Speed Dial
  - ◆ Voice Dial
  - ◆ No Label
  - ◆ Fax
  - ◆ Pager
  - ◆ Mobile
  - ◆ Office
  - ◆ Home
4. Select Speed Dial and press .
5. Press  to save and exit.

## Storing phone numbers at the end of a call

To store a phone number after ending a call:

**Note:** If the call was incoming, and Caller ID information was unavailable, then the store option will be unavailable.

1. Once you have pressed  to end your call, the screen displays the call time (length of call), phone number of the party (if available), and the “OK: Save” option.
2. To add a new phone number, press . The procedure from this point is the same as “To add a new phone number to the Phone Book” on page 65.

## Shortcuts to Storing Phone Numbers

You can store a phone number quickly by entering the number, and then pressing . Then follow the prompts to designate the label, name and entry. You can quickly save a number after an incoming or outgoing call.

# Dialing numbers from the phone book





Dialing numbers from your Phone Book is quick and easy. Different methods are explained below:

## Shortcuts to Memory Dialing

Speed Dialing:

From standby mode, enter the number of the memory location, and press the number for the required option.

Scrolling to the number:



From standby mode, press the  key and toggle using the  key to Phone Book. Press  to enter the Phone Book. Toggle until the desired option is reached then press  to enter the option.

**Note:** For the One-Touch, Two Touch, and Three Touch dialing to work as described, the category setting in the phone book must be set to Speed Dialing for the entry.



One-Touch Dialing:

Memory locations 01 through 09 are special One-Touch locations. You can dial the phone numbers stored in the Phone Book memory from 01 through 09 simply by pressing one key. For example, for location number 001. Press  and hold. The name and number is displayed and dialed.

### Two-Touch Dialing:

Memory locations 10 through 99 are special Two-Touch locations. For example, for location number 013. Press  and then hold down . The name and number is displayed and dialed.

### Three-Touch Dialing

Memory locations 100 - 500 are special Three-Touch locations. For example, for location 112. Press   and hold down . The name and number is displayed and dialed.

**Note:** The number 411 has been automatically saved in memory location 411. To dial 411, use the Three-Touch dialing instructions. If you overwrite memory location 411, you will need to dial the entire number and press “Send” to complete the call.

**Note:** The number 311 has been automatically saved in memory location 311. To dial 311, use the Three-Touch dialing instructions. If you overwrite memory location 311, you will need to dial the entire number and press “Send” to complete the call.

**Note:** The number 211 has been automatically saved in memory location 211. To dial 211, use the Three-Touch dialing instructions. If you overwrite memory location 211, you will need to dial the entire number and press “Send” to complete the call.

# Web/MiniBrowser

Your phone comes equipped with wireless Internet access by using the MiniBrowser.

The MiniBrowser allows you to access up-to-the-minute information through your phone. View specially designed versions of popular Internet sites which may include news, sports, weather, stock quotes, etc. Browsing the web through your phone is unlike using your personal computer since site providers have selected only the critical aspects of the site to present to wireless phone users and have removed most graphics.

Each time you launch the MiniBrowser, the phone connects to the Internet and the service indicator icon (  ) displays. Any time the service indicator icon is visible on the display, you are connected and are invoiced accordingly. Rates and pricing vary according to your service option. Please contact your service provider for more details.

**Note:** The phone must be in a digital network to use the MiniBrowser. When you are in a digital network, the  icon is displayed.

## Launching the Minibrowser

**Note:** The first time you use the MiniBrowser, you will be required to go through a security setup process that takes approximately three to five minutes. Please follow the on-screen prompts to complete the security setup process. This initial setup process occurs only the first time you access the service.

**Note:** When the security key is initially sent to the carrier, it creates a unique value. If the phone is reset for any reason, you must contact the carrier to reset the security key. The old key is no longer valid and will not allow the MiniBrowser to operate correctly.

To launch the web:

1. Press .

2. Press .

3. Press .

**Note:** A reminder of the charge may appear (depending on your prompt setting - see “The MiniBrowser Start and End Prompts” on page 71). To dismiss the prompt, simply choose yes or no. If no prompt is displayed, you are immediately connected to the internet.

4. Toggle  to select Yes or No.





5. Once connected, the Home page (or the last page visited) will be displayed. To access the Home menu page from any other menu in the MiniBrowser, press and hold .

**Note:** What displays when accessing the MiniBrowser is dependent on the service provider content. To view additional text, use the scroll keys.

**Note:** You can also access the Web/MiniBrowser by pressing  on the right side of the phone's display screen.







## Exiting the Web/Minibrowser

1. Press  to exit the web or close the flip.



2. Press  to exit the MiniBrowser. If the ‘Prompt to end’ or ‘Prompt both’ option is selected in the MiniBrowser setup (    ), you will be prompted whether you want to end the MiniBrowser call.

## The MiniBrowser Start and End Prompts

Your phone can be set to view a prompt each time you start or end a MiniBrowser session. You have the option to change when the start prompt is displayed. The default setting is set to start prompt. To change the settings:

1. Press  to display the menu.
2. Press  for Web
3. Press  for Prompt.
4. Use the  button to select one of the four options:
  - ◆ **To Start:** (This is the default setting. You will see the prompt when you enter the browser, but not when you exit it.)
  - ◆ **To End:** (You will see the prompt only when you exit the browser.)
  - ◆ **Both:** (You will be prompted when you enter or exit the browser.)
  - ◆ **None:** (You will never see this prompt.)
5. Press  to save your setting or  to cancel.

## The MiniBrowser Soft Keys

At the bottom of the MiniBrowser display is a solid bar which contains browser commands. “Soft” keys(   ) below the solid bar are used to execute the commands. These two keys are called “soft” keys because their function changes depending on where you are in the MiniBrowser software.

## Navigating the Web

When you use the MiniBrowser, some keys on your phone operate differently than during a normal phone call. These keys are explained below. The MiniBrowser presents on-screen items in one of the following ways:

- ◆ Text or numeric input
- ◆ Links (embedded in content)
- ◆ Numbered options (some options may not be numbered)
- ◆ Simple text

You can select options or links by using the soft keys.

## How the Keys Work in the MiniBrowser

**Up/down navigation keys:** Use the navigation keys to scroll to and select from MiniBrowser options. The currently selected option is indicated by an arrow. You can also use the navigation keys to move the cursor when editing text.



**OK/Navigation key:** This key is also used for selecting the highlighted item by pressing down the button. This button is also used with the internet. (see “The MiniBrowser Soft Keys” on page 72).





**Volume keys:** These keys allow you to scroll up or down or change the volume settings.



**CLR key:** This key performs two functions:

- ◆ Backs you up in the browser. Pressing it once backs you up one page. Pressing and holding it down backs you up to the Home page.

- ◆ Clears out entered text or numbers. When entering numbers or text, press  to clear the last number, letter, or symbol.

Press and hold  to completely clear the input field.



**Asterisk / shift key:** This is the shift key. Press before entering text to create upper case letters. This key is also used to scroll down or up a line at a time.



**0 / next key:** Enters a 0. Moves to the next word in T9 word mode.



**Pound / space key:** This is the space key. Press to insert a space when entering text. This key is also used to scroll down or up a line at a time.



**Numbered keys 0 - 9:** If items on a menu are numbered, these keys can be used to select them.



**END key:** Exits the MiniBrowser and returns the phone to standby mode.

**MENU**

**MENU key:** This is the right soft key. The right soft key is used to access secondary options, or a menu of secondary options.

## Entering Text, Numbers, or Symbols



At various times when using your phone, you will need to enter text. For example, when storing a name in the Phone Book, entering events in your Calendar, or creating a bookmark in the MiniBrowser.

Pressing the **MENU** key gives you the following options:

- ◆ T9 Word
- ◆ ABC
- ◆ Symbol
- ◆ 123

Toggle through the options presented and press the  key to select.



Entering text, numbers, or symbols:

- ◆ Press  to insert a space.
- ◆ Press **CLR** to clear the last number, letter, or symbol, or Press and hold **CLR** to completely clear the input field.
- ◆ Press **MENU** to display the options then  to change and lock in the option of choice.

## Alphabetical Text Entry

Alphabetical text characters may be entered in the alpha Input Mode by pressing the key corresponding to the letter that you want to enter. Press the same key repeatedly to change between the characters represented by each key. To change capitalization formats while entering text, press the  key. The menu key allows you to choose from 4 options:



- ◆ **alpha:** See Note: below.
- ◆ **Sym:** For numbers that have symbols associated.
- ◆ **Num:** For numbers
- ◆ **T9 Word:** Recognizes and types whole words

**Note:** For example, you quickly press  three times to display the letter 'C', and quickly press the  key twice to display the letter 'K'. This is called multi-tap typing.

## Number Entry

Numeric mode enables you to enter numbers into a text message. Press the keys corresponding to the desired digits, and manually switch back to text entry mode of choice.

## Symbol Entry

Symbol mode enables you to enter symbols into a text message. Use the **MENU** key to display the options and press the  key up or down select the symbol option. When displayed toggle using the  to select the symbols. When in Symbol input mode, press the key shown on the display under the symbol that you desire to enter.

Here are the list of available symbol characters:



◆		! _ \ ;
◆		@ + ? ;
◆		# = . ;
◆		% : , <<
◆		& “ { >>
◆		* ‘ } ±
◆		< ( \$ ^
◆		> ) [ .
◆		- / ] °

## Word or T9® Text Entry

T9word, T9 Text Input, enables you to easily enter text.

T9 (for “text on 9 keys”) requires only one key press per letter and quickly recognizes the most commonly used word of a numeric sequence.

For example, to enter the word “hello,” you can spell out the word by pressing only five keys, 4-3-5-5-6. T9 Text Input knows the most commonly used sequence for that numeric sequence is “hello”.

If two or more words share the same numeric sequence, T9 software provides the most commonly used word, with the ability to scroll to the next most commonly used word by pressing  up or down. Press  repeatedly to display all of the available words that T9 knows. When the word you want displays, continue to enter text in the same way, or change to another text or character entry mode. If the word you want to enter is not known by T9 press  to change the Input Mode.





**Note:** To type words not found in the T9 mode, change the text input mode to Alpha mode. Words typed in this mode are automatically added to the T9 dictionary so you can type them using the T9 English mode the next time. You can include numbers between letters without exiting the T9 input mode by simply pressing and holding the desired numeric key.







# Scheduler

## Today

You can schedule up to 9 events for the current day by indicating each event's start and end time. You can be alerted by the Calendar function before an event is commenced. Events that are scheduled for future dates automatically display on your Today events schedule for that particular day.



### How to schedule an event:





1. Press  to display the menu.
2. Press  for Scheduler.
3. Press  for Today the New Event screen displays.
4. Pressing the  key will offer further options. For example:
  - ◆ T9 Word
  - ◆ ABC
  - ◆ Symbol
  - ◆ 123
  - ◆ Exit
5. Choose your option by pressing the scroll key in the center and enter your event information. Up to 32 characters can be entered. For more information on Text and Symbol Entry see “Entering Text, Numbers, or Symbols” on page 75.
6. Press  to continue, the start time and date screen displays.

7. Add the start time and date using the numeric keys, then press the  key to display the next screen.
8. Add the end time and date. Press  to save the information.
9. If an error is made, or duplicate information is already saved, pressing the  key offers the following options:
  - ◆ Add new
  - ◆ Edit
  - ◆ Erase
10. Using , scroll through the options and press  to select.
11. After the correct information has been entered, an alarm screen is displayed. Select an alarm to notify you of your event. Your Alarm options are: 10 minutes Before, 30 minutes Before, 1 hour Before, No Alarm and On Time. Make your choice and press .
12. This action will return you to standby mode.



## View Month

View month permits you to view, in calendar format, the current month, a past month, or future month. In view month, the current date is highlighted on the calendar. Days with scheduled events are underlined.

1. Press  to display the menu.
2. Press  for Scheduler.
3. Press  for View Month. The Calendar displays.
  - ◆ Remember, the current date is highlighted.

- ◆ Use the navigation key to select the month and day.
4. Pressing the Menu key displays two options in the upper right corner of the display screen, they are:
    - ◆ View (Permits you to view previous calendar entries).
    - ◆ Add New (Permits you to add a new calendar entry).
  5. To enter a new event, enter your event information. Up to 32 characters can be entered. For more information on Text and Symbol Entry see “Entering Text, Numbers, or Symbols” on page 75.
  6. Press  to accept your entry.
  7. Enter the start time and date, and press  to save the information. The end time and date screen are displayed.
  8. Enter the start time and date, and press  to save the information.
  9. The alarm screen displays. Scroll to select an alarm to notify you of your event. Your Alarm options are: 10 minutes Before, 30 minutes Before, 1 hour Before, No Alarm and On Time.
  10. Press  to save your selection.





### How to view an event:

1. Press  to display the menu.
2. Press  for Scheduler.
3. Press  for View Month and the Calendar displays.

4. Use the navigation key to display all of an event's information. If more than one event is scheduled, use the navigation key to display them.
5. Press  to display the options. Select one of the following:
  - ◆ **Add New:** Allows you to add an event
  - ◆ **Edit:** Allows you to edit the event
  - ◆ **Erase:** Allows you to delete the event.
6. After an option is selected follow the display prompts to continue.

## Calendar

Your phone features a Calendar to keep track of important dates and events. It enables you to create To Do Lists, set a Count Down alarm, check the time in another part of the world, and perform numerical calculations.

1. To access your Calendar press    .
2. Press the  key to access one of the Calendar options, or navigate to the option.
3. Press  to access that option.

Calendar has the following options:

- ◆ T9 Word
- ◆ ABC
- ◆ Symbol
- ◆ 123
- ◆ Exit









## Date

Allows you to specify the calendar date you wish to view. Once this date has been entered into the display screen it allows you to view other events with the same date.

### Jump to date

Jump To Date allows you to specify the calendar date you wish to view. Once the date is obtained you can enter, edit and erase events in your calendar. For further information see “Calendar” on page 82









### Using jump to date

1. Press  to display the menu.
2. Press  for Scheduler.
3. Press  for Date.
4. Enter the date of the event and press  to continue.
5. The Calendar screen displays the newly entered highlighted date.
6. Pressing the  key displays the options View and Add new.
7. Scroll to view and press the  key.
8. Pressing the  key opens the Add new, Edit, Erase options.
9. You can either schedule a new event or edit or erase an old one. Press the  key to select the option.



## To Do List



The To Do List can help you keep track of, and prioritize the things you need to do. You can enter and prioritize up to 30 items.

### How to create a to do list

1. Press  to display the menu.
2. Press  for Scheduler.
3. Press  for To Do List.
4. Select the  key for options.
5. Select the required option by toggling the  key.
6. Enter your To Do Item.
7. Press  to save. This action opens the Time/Date screen.
8. Enter the time and date and press  to continue.
9. Using the navigation keys, set the priority for a To Do List item. Your choices are High and Low.
10. Press  to save your prioritized To Do List item.

### To view, edit, add, or erase to do list items

1. Press  for the menu.
2. Press  for Scheduler.
3. Press  for the To Do List.





4. Press  and using the navigation keys find the To Do List item you want to change.
5. Press the  key to select the correct option. Your choices are:
  - ◆ Add New
  - ◆ Edit
  - ◆ Erase
6. Continue to add a new item, edit or erase an existing item by following the prompts.

## Countdown

Have you ever wanted to know how much time it takes you to do something, or how many minutes, hours, days and months until a special event? The Countdown option can help you answer these questions. You can create up to 30 countdown timers using this feature.

### Creating a Countdown item

Use this procedure the first time you program a countdown timer or if you've erased them all.

1. Press  to display the menu.
2. Press  for Scheduler.
3. Press  for Countdown.
4. The screen prompts for new countdown. Enter a name for your new countdown timer.
5. Press  when complete.

6. Enter the date and time that you want to “Countdown” to. For example, if today’s date is November 10, 2000 and you wish to know how many months, days, and hours are left before 7:00 PM February 14, 2001 enter the time 07:00 PM and the date 02/14/2001.

◆ You can press the digital keys  or  for AM or PM. The volume keys can also be used to toggle between AM and PM.

◆ Countdown timers can be entered for dates up to 2099.

7. Press  to store the countdown timer.

### Adding, editing, and erasing a countdown item

Use this procedure if you have a countdown timer(s) already programmed.

1. Press  to display the menu.

2. Press  for Scheduler.

3. Press  for Countdown.

◆ Countdown timers display in order of the least amount of time passed since the countdown commenced, and least amount of time remaining until the specified date.

4. Press  to display options.

◆ Follow the screen prompts to enter a new countdown timer.

◆ Follow the screen prompts to edit the timer.







◆ Follow the screen prompts to erase the timer.

◆ Press  for Exit. This returns the screen to viewing the already programmed countdown timer(s).

## World Time

World Time displays what time it is in twenty-four different time zones around the world together with one or more major cities, states, regions or countries in a time zone.





### Checking the Current Time in Another City or Country

1. Press  to display the menu.
2. Press  for Scheduler
3. Press  for World Time
4. The display screen shows two globes. Both set to the GMT default.
5. Press  to change time zone.
6. Press  or  to return to standby mode.

## Calculate

You can perform calculations including addition, subtraction, multiplication and division on your phone.

### Performing a calculation

1. Press  to display the menu.
2. Press  for Scheduler.
3. Press  for Calculator.
4. Press digit keys to enter the first number in your calculation. Numbers can be up to 9 digits long.
  - ◆ Press  to enter a decimal point.

◆ Press  to change the sign of a number to a negative (-).

5. Use the scroll keys (  ) to set the operator for your calculation. Your choices are:

◆ [+] addition

◆ [-] subtraction

◆ [x] multiplication

◆ [/] division

6. Press the digit keys to enter the second number of your calculation.

7. Press  to perform the calculation and see the result, or:







8. You can continue to perform calculations with the same operator or change the operator and continue your calculations. Every time that you change the operator, the previous calculation is performed and the result is displayed as the top number in the display.

9. Press  to perform the calculation and view the result.







## Alarm

Your phone has an alarm clock function with three separate alarms. Each alarm can be set to go off once, or daily at a set programmed time. Once you set an alarm, it is easy to change it's time or to turn it off.

### Alarm set

1. Press  to display the menu.
2. Press  for Scheduler.
3. Press  for Alarm Clock.
4. Select the alarm you want to set by pressing  , to the left or right. Your choices are 'Once' 'Daily', or 'Off'.
5. Press  to select the desired alarm.
6. Follow the prompts to save the alarm setting of choice.
7. Press  to return to the previous menu.

### To edit a programmed alarm



1. Press  to display the menu.
2. Press  for Scheduler.
3. Press  for Alarm Clock.
4. Select the alarm you want to set by pressing  , to the left or right. Your choices are 'Once' 'Daily', or 'Off'. Press  .
5. Edit the time and press  .

# Sounds



## Ringer Options

Your phone provides a variety of ringer options through the Sounds menu. These options allow you to customize your ringer type and ringer volume settings in order to easily recognize a certain type of incoming call.

## Adjusting Ringer Volume (Quickly)



From the standby mode, you can adjust the volume of the ringer by pressing the volume keys   on the side of the phone (8 levels) as well as to 1 Beep/Vibrate. If the flip is open while you are making this setting, leave it open until the phone returns to standby mode (this allows the phone time to store the setting).



## Adjusting Voice Volume during a Call

You can adjust the (optional) headset volume during a call using the volume keys   on the side of your phone

## Ringer Volume

Three options can be found under the Ringer Volume option for Sounds. To activate these options:

1. Press  to display the menu.
2. Press  for Sounds.
3. Press  for Ringer Volume. The three options display.
  - ◆ 1 Calls
  - ◆ 2 Messages
  - ◆ 3 Alarm.

4. Either press the numeric key, or scroll to the option and select it. The screen displays the volume icon which changes according to the setting selected.
5. Press  to save the desired volume. The display icon changes to reflect the new setting.
6. When the desired setting is reached, press the  key to save the setting.
7. You can press the  key to return to the previous menu at any time.



## Ringer Type



Five options are found for Ringer type in the Sounds menu. They are:

- ◆ Voice Calls
- ◆ Messages
- ◆ Alarm
- ◆ Data/Fax In
- ◆ Schedule

Each of these allows you to specify the desired type of ringer.





To activate these options:

1. Press  to display the menu.
2. Press  for Sounds.
3. Press  for Ringer Type.

4. Either press the numeric key, or scroll and select the option of choice using the  key to activate that option.
5. Press the scroll key to scan through the nine ringer types, twenty four melody tones, and ten downloadable ring tones. Each tone plays as you scroll through the options.
6. When the desired ringer type is displayed, press  key to save the setting.

## Voice Calls

To activate these options:

1. Press  to display the menu.
2. Press  for Sounds.
3. Press  for Ringer Type.
4. Press  for Voice Calls.

Use the scroll key to select from the twenty four melody tones, nine distinctive rings, and ten downloaded ring tones. To select your choice of melody or ringers, press .





## Messages

The Messages menu contains three options:

- ◆ Voicemail
- ◆ Text
- ◆ Web MSG

To activate these options:

1. Press  to display the menu.

2. Press  for Sounds.
3. Press  for Ringer Type.
4. Press  for Messages.
5. Press the corresponding numeric key, or scroll to select the type of message option then choose from twenty four melody tones, nine distinctive rings, and ten downloadable ring tones. To lock in your choice of melody or ringer press .
6. To cancel, press  to return to the previous menu.



## Browser MSG

Browser messages are messages that are received from the Internet. You must have an account setup online for this option.

**Note:** You must have web service from the carrier for this option to work. Any email that is received on your internet account is displayed. To send a message, the person enters your phone number.

### Viewing Browser Messages



To view browser messages:

1. Press  to display the Mail Kit menu.
2. Press  for Inbox.
3. Press  for Web.

### Key Beep

Key Beep allows you to designate the volume of the tone when a key is pressed on the phone. There are nine levels of volume associated with the key beep.

To activate Key Beep:

1. Press  to display the menu.
2. Press  for Sounds.
3. Press  for Key Beep.







### Alerts

Your phone beeps to notify you of an event or action, this is called an alert. You can easily turn alert beeps on or off. The other party does not hear the alerts when you are using the phone.

## Minute beep





You can set the minute beep option to sound an alert 10 seconds before each elapsed minute to remind you of the length of the current call.

To turn minute beep on or off:

1. Press  to display the menu.
2. Press  for Sounds.
3. Press  for Alerts.
4. Press  for Minute Beep.
5. Scroll through the Alert menu between On/Off. When the desired setting is displayed, press  to save.
6. To cancel, press  to return to the previous menu.

## Service

To set the service alert On or Off:







1. Press  to display the menu.
2. Press  for Sounds.
3. Press  for Alerts.
4. Press  for Service.
5. Scroll between On/Off. When the desired setting is displayed, press  to save.

6. To cancel, press  to return to the previous menu.

## Connect

With the Connect option set to on, the phone sounds a connect alert tone when your call is connected.





To set the connect alert On or Off:



1. Press  to display the menu.
2. Press  for Sounds.
3. Press  for Alerts.
4. Press  for Connect.
5. Scroll between On/Off. When the desired setting is displayed, press  to save.
6. To cancel, press  to return to the previous menu.

## Disconnect

When the Disconnect option is set to on, the phone sounds a disconnect alert tone a call is dropped or failed.



To set the disconnect alert On or Off:

1. Press  to display the menu.
2. Press  for Sounds.
3. Press  for Alerts.
4. Press  for Disconnect.







5. Scroll between On/Off. When the desired setting is displayed, press  to save.
6. To cancel, press  to return to the previous menu.

## Fade

When the Fade menu option is set to on, the phone sounds an alert when a dropped call occurs during conversation because of a signal fade.

- ◆ Press  to clear the message and return to standby mode.
- ◆ If the dropped call was an outgoing call from your phone, you can redial the number automatically by pressing  twice.







To set the fade alert On or Off:

1. Press  to display the menu.
2. Press  for Sounds.
3. Press  for Alerts.
4. Press  for Fade.
5. Scroll between On/Off. When the desired setting is displayed, press  to save.
6. To cancel, press  to return to the previous menu.

## Network Alert





When the network alert option is turned ON, a distinctive alert tone is heard when you leave the network coverage area.

To set alert option ON or OFF:

1. Press  to display the menu.
2. Press  for Sounds.
3. Press  for Alerts.
4. Press  for Network.
5. Scroll between On/Off. When the desired setting is displayed, press  to save.
6. To cancel, press  to return to the previous menu at any time.

## Voice Volume

The Voice Volume option allows you to adjust the voice volume of the receiver.





1. Press  to display the menu.
2. Press  for Sounds.
3. Press  for Voice Volume.
4. Scroll between Softest - Loudest. When the desired setting is displayed, press  to save.
5. To cancel, press  key to return to the previous menu.

**Note:** The volume keys can be used to adjust the call volume during a call.

## Roam Ringer

When this option is ON, a distinctive ringer is heard when an incoming call is received outside your local coverage area.

To set the ringer ON or OFF:





1. Press  to display the menu.
2. Press  for Sounds.
3. Press  for Roam Ringer.
4. Scroll between On/Off. When the desired setting is displayed, press  to save.
5. To cancel, press  to return to the previous menu.

## Power On/Off

When the Power On/Off option is set to on, the phone sounds an alert when:

- ◆ When the handset is powered on or off.
- ◆ The phone experiences a dropped or failed call.
- ◆ The phone enters or leaves a service area.

To set the sound alert On or Off:

1. Press  to display the menu.
2. Press  for Sounds.
3. Press  for the Power On/Off display screen.
4. Scroll between Sound On/Off. When the desired setting is displayed, press  to save.
5. To cancel, press  to return to the previous menu.

# Display

These settings determine what is displayed on the phone's LCD screen.

## Display Options

Your phone has several display options. They allow you to:



- ◆ Display your own phone number.
- ◆ Control when and how long your backlight is active.
- ◆ Define a personal greeting up to 30 characters.
- ◆ Set the language (English or Spanish) used on your screen.
- ◆ View hardware and software versions of your phone.

## Backlight

There are several options for setting the backlight features.

When the phone flip is closed, the backlight remains off conserving battery power. When the flip is open, the length of time that the backlight remains active can be set to 7, 15, or 30 seconds.

To select backlight options:

1. Press  to display the menu.
2. Press  for Display.
3. Press  for Backlight.

4. Scroll through the menu options:

◆ Always Off

◆ Always On

◆ 7 seconds

◆ 15 seconds

◆ 30 Seconds

◆ on when flip open

5. When the desired option is displayed, press  to save.

## Banner

The Banner option allows you to edit the banner displayed on the standby screen. It can also be used as your ID when sending an e-mail.

Enter the banner desired using the alphanumeric keys.

To select banner options:

1. Press  to display the menu.

2. Press  for Display.

3. Press  for Banner.

4. Press  to view the options:



◆ T9 Word

◆ ABC

◆ Symbol

◆ 123



◆ Exit









5. Press  to scroll through the options.
6. When the desired option is displayed, press  to select.
7. Enter your banner.
8. Select  to save it.

## Animation

The Animation option allows you to select the animation sequence for your phone.

To select animation options:



1. Press  to display the menu.
2. Press  for Display.
3. Press  for Animation. The options appearing on the display screen are:
  - ◆ Power on
  - ◆ Power off
  - ◆ Idle 1
  - ◆ Idle 2
4. Choosing the 'Power on' option allows you to scroll through 8 different animation images.

5. When the desired option is displayed, press  to save.
6. Pressing  returns you to the Animation options menu.
7. Choosing the 'Power off' option allows you to scroll through the animation images available.
8. When the desired option is displayed, press  to save the setting. Selecting  returns you to the Animation options menu.
9. Choosing the 'Idle 1' option allows you to scroll through the 8 Idle 1 images available.
10. When the desired option is displayed, press  to save.
11. Pressing  returns you to the Animation options menu.
12. Choosing the 'Idle 2' option allows you to scroll through the 8 Idle 2 images available.
13. When the desired option is displayed, press  to save the setting.
14. Pressing  returns you to the Animation options menu.

## My Phone Number



The My Phone Number option displays the telephone number of the phone.

To display my phone number:

1. Press  to display the menu.
2. Press  for the Display.

3. Press  for My Phone#.





### To view your phone number during a conversation:

1. Press  to display the In-Use Menu.
2. Press  for My Phone #. Your number is displayed.
3. Press  to return to the previous menu.

## Language

The Language option changes the language on the phone to English, French, or Spanish.





To change languages:

1. Press  to display the menu.
2. Press  for Display.
3. Press  for Language.
4. Scroll between English, French, or Spanish.
5. When the desired option is displayed, press  to save.

## Set Time

Your phone is equipped with a standard clock.





To set the clock:

1. Press  to display the menu.
2. Press  for Display.
3. Press  for Set Time.
4. Scroll to select On or Off.
5. When the desired option is displayed, press  to save the setting.
6. Press  to return to the previous menu.

## Auto Hyphen

With the Auto Hyphen option set to on, your phone can automatically hyphenate numbers. For example: 972-761-0000.





Here's how it is configured:

1. Press  to display the menu.
2. Press  for Display.
3. Press  for Auto Hyphen.
4. When the desired option is displayed, press  to save.
5. Pressing  returns you to the previous menu.

## LCD Contrast

The LCD (Liquid Crystal Display) has contrast setting that can help you see the screen better in different lighting conditions.

To set the LCD contrast:





1. Press  to display the menu.
2. Press  for Display.
3. Press  for LCD Contrast.
4. Scroll between the contrast settings to determine the most visible.
5. When the desired contrast setting is displayed, press  to save.

## Version

The Version menu displays the current hardware/software version that is installed in your phone.

This feature is helpful if you need to call customer care.

To view the version:

1. Press  to display the menu.
2. Press  for Display.
3. Press  to view the Version information.
4. Press  to quit.
5. Press  to return to the previous screen.

# Voice dial

## Voice Dialing

Your phone features voice dialing. When on a digital or analog network, you can call up to 20 stored names simply by speaking the name into the microphone. Using the voice dialing option requires that you first program the phone to recognize the name of the person you are calling.





## Tips on Recording Names

- ◆ Avoid recording similar names phonetically. If you record a similar name to one that is already stored in voice-dial memory, the phone requests another name.
- ◆ Avoid recording in a noisy place.
- ◆ Speak clearly and naturally.
- ◆ Avoid very long or very short names. Names with two to five syllables are recommended.
- ◆ If the voice dial entry does not connect properly, you may need to record the name and number again.

## Record

The phone provides voice prompts and screen displays to guide you through the recording process.





To program the phone for voice dialing:

1. Press  to display the menu.
2. Press  for Voice Dial.
3. Press  for Record. The phone prompts you to record a name.
4. Wait for a beep and then say the name. The phone stores the name and then prompts you to speak the name again.
5. Respond to the prompt by repeating the name after the beep exactly as you did the first time. If the name is accepted, the phone requests the phone number.
6. Enter the phone number using the key pad.
7. To store the phone number, press . The number you entered displays, along with the notification 'Recorded'. If the number you entered matches a name/number already stored in your Phone Book, then the name also displays, together with the notification 'Recorded'.
8. The screen returns to the Phone Book menu.
9. This option allows you to add, edit, or erase individual voice dial entries. A list of entries displays.







## Play/Erase

The Play/Erase option is used to review and erase dialing entries.

### To play voice dialing entries:

1. Press  to display the menu.
2. Press  for Voice Dial.
3. Press  for Review. A list of stored voice dial numbers displays. (The names also display if stored in the Phone Book).
4. Press the digit key to select the desired entry or scroll to the desired entry and press . The recorded name is vocalized. You can quickly scroll entries without having to listen to each one, or you can listen to them all as they play in order.
5. Press  to return to the previous screen.
6. When the last entry is played, the phone returns to standby mode.

### To erase all voice dialing entries:

1. Press  to display the menu.
2. Press  for Voice Dial.
3. Press  for Play/Erase
4. Press   for Erase All.
5. Press  to Erase All the entries. The display screen will inform you when this action has taken place.





6. If you wish to exit without removing any voice dialing entries press  and you will return to the previous menu.

## Set Active

Voice dialing is always on once you have programmed the phone to accept voice dialing entries and associated the phone numbers. To place voice dialing calls, press and hold . Then say the name into the phone after you hear the voice prompt and the beep.

You can also initiate a voice dialing call by simply opening the phone's flip (this option is selected through the menu).



To change voice dialing setup options:

1. Press  to display the menu.
2. Press  for Voice Dial.
3. Press  for Set Active.
4. Scroll between the following options:
  - ◆ Enables voice dialing only by pressing and holding .
  - ◆ Enables voice dialing when the phone's flip is open.

## Training

To use voice dialing, you must train the phone. To train the phone, you are asked to say the word 'Yes' and then to repeat it. You are then asked to say the word 'No' and to repeat it.



To train your phone:

1. Press  to display the menu.
2. Press  for Voice Dial.

3. Press  for Training.
4. Hold the phone to your ear and follow the instructions.

## Undo Train

To undo the training, follow these steps:

1. Press  to display the menu.
2. Press  for Voice Dial.
3. Press  for Undo Training.

Your phone's screen displays 'un-training control words proceed?'

Select  to 'Un train' or  to return to the previous menu.

# Voice memo

## Voice Memo

Your phone can record five separate voice memos. The total voice memo time for all five memos can be up to four minutes in length. When recording, a timer is displayed that indicates the length of the recording. An alert sounds and the phone tells you that the recording time has expired.

1. Press  to display the menu.

**Note:** You can also press the voice memo button located on the side of the phone.

2. Press  for Voice Record.

3. Press  for Voice Memo.

4. The screen displays:  
“Begin recording after the prompt tone”.

5. Speak into the phone to record the Voice Memo.





6. Press  to stop recording.

7. The Record Finished screen is displayed with the following choices:

◆ 1. Review









◆ 2. Rerecord

◆ 3. save

8. Press  to review the voice memo. The screen displays the length of the recording with the date and time.
9. Press  to rerecord the voice memo.
10. Press  to save the voice memo and add a title.
11. The Title Edit screen is displayed. Enter a title and press  to save.

## Play/Erase

To review a voice memo:

1. Press  to display the menu.
2. Press  to display the Voice Record menu.
3. Press  for the Voice Memo menu.
4. Press  for Play/Erase. The Vmemo List is displayed.
  - ◆ Press  to play the voice memo.
  - ◆ Press  to go back to the previous menu or pause a playing voice memo.
  - ◆ Press  to list the following options:
    - Info** - Displays info about the voice memo
    - Erase** - Erases the voice memo
    - Erase All** - Erases all voice memos
5. After reviewing the voice memos, press  to return to standby mode or close the flip.





# Call Answer

Call Answer allows you to have incoming messages stored directly into the phone. When the Call Answer option is turned on, the callers message is recorded directly into memory. This uses the voice memo memory, so the amount of time available is dependent on the available memory less any voice memos. The total talk time is 240 seconds.

## On/Off

This option allows you to activate the option to enable Call Answering.

To enable Call Answering:

1. Press  to display the menu.
2. Press  for Voice Record.
3. Press  for Call Answer.
4. The screen displays:
  - ◆ 1. On/Off
  - ◆ 2. Config
  - ◆ 3. Inbox
5. Press  to enable or disable Call Answering.
6. Press  to select Config. The screen displays:
  - ◆ Screening - This menu turns the screening speaker on/off.

- ◆ Wait Time - The wait time can be set to No Ring, After 3 sec, 5 sec, or 10 sec.

7. Press  to save your choice and return to the previous screen

8. Pressing  returns you to the previous screen.

## Default Greeting

A default greeting is used to welcome incoming callers when the Call Answer option is enabled. The default message is “Please leave a brief message after the tone”.

## Call Screen

Use this option to activate the Call screening feature.



1. Press  to display the menu.

2. Press  for Voice Record.

3. Press  for Call Answer.

4. Press  for Config.









5. Press  for Screening. The Call screening feature will display.

6. Press  to toggle between Screening Speaker On or Off. Press  to save your option.









7. Press  to return to the previous screen.

## Wait Time

Use this option to set the amount of time the caller waits to leave a message on the phone.

1. Press  to display the menu.
2. Press  for Voice Record.
3. Press  for Call Answer.
4. Press  for Config.
5. Press  for Wait Time.
6. Press  left or right to display the following wait times:
  - ◆ No Ring
  - ◆ After 3 seconds
  - ◆ After 5 seconds
  - ◆ After 10 seconds
7. Press  down and highlight “Save”.
8. Press  again to save.

## Inbox

1. Press  to display the menu.
2. Press  for Voice Record.
3. Press  for Call Answer.
4. Press  for Inbox.
5. The Message List is displayed. The following options are available:
  - ◆ Press  to Play the message.
  - ◆ Press  to go back.
  - ◆ Press  for option.
6. If  is pressed, the following options are available:
  - ◆ Info - Press 1 to displays detailed information about the call.
  - ◆ Erase - Press 2 to erase the message.
  - ◆ Erase All - Press 3 to erase all messages.
  - ◆ Talk - Press 4 to call the number.
  - ◆ Save - Press 5 to save the number in the Phone Book.

# Games





## Game Menu

Using your phone you have the ability to play the following games:

1. Push Push
2. Fly Ribon
3. Puzzle World
4. Spider Hunter

## Push Push

To open Push Push:

1. Press  to display the menu.
2. Press  for the Games menu.
3. Press  for the Push Push game.
4. When the game's 'start screen' is displayed, press  to start and press  for key commands.

## Object

The object of the game is to push the balls into the little house. The ball can be pushed left, right, up, or down. It cannot however be pushed backwards. There must always be a space to push the ball forward or else the ball is stuck and the level cannot be completed. Two balls cannot be pushed together, only one ball at a time may be pushed. Once the ball has been pushed into the house, another ball

can push the house if another house is located behind it. You can go back one move by pressing .

## Key Commands

The following options are displayed when available:

**KEY HELPER:** Displays each key's function.

 - Move Up

 - Move Down

 - Move Left

 - Move Right

 - Previous stage

 - Next stage





 - Restart stage

**CLR** - Undo

**END** - Exit

## Fly Ribon

To open Fly Ribon:

1. Press  to display the menu.
2. Press  for the Games menu.
3. Press  for the Fly Ribon game.
4. Press  to start.

## Object





The object of the game is to fly the ribbon through a maze of obstacles. To control the path of the ribbon, use the  button.

Move



the flight path of the ribbon up or down to avoid the wall. The longer the distance, the faster the ribbon goes.

## Puzzle World

To open Puzzle World:





1. Press  to display the menu.
2. Press  for the Games menu.
3. Press  for the Puzzle World game.
4. Use  to select the type of puzzle. The choices are 3x3 or 4x4.

## Object

The object of the game is to rearrange the tiles of the puzzle to make the picture display correctly. To rearrange the tiles, you can move a tile to the next available slot using the  key. If you cannot figure out the puzzle, press  to solve.

## Spider Hunter

To open Spider Hunter:

1. Press  to display the menu.
2. Press  for the Games menu.
3. Press  for the Spider Hunter game.
4. Press any key to start the game.
5. Select the level by pressing  for easy or  for hard.

### Object





The object of the game is to drop the potted plants on the spiders from the top of the wall. To drop the plants, press the  key. The spiders will attempt to reach the top of the wall. You start out with three hearts. If a spider reaches the top, you lose one heart. When you lose all three, the game is over. A high score is recorded each time you play.

# Setup

## Auto Retry

When the Auto retry option is activated, your phone automatically retries the last call up to ten times when a connection fails.

How to enable Auto Retry.







1. Press  to display the menu.
2. Press  for Setup.
3. Press  for Auto Retry. The Auto Retry screen displays.
4. Press  to toggle between Off, every 10 seconds, every 30 seconds and every 60 seconds. Press the same key in the center to save your option.
5. Pressing  returns you to the previous screen.

## Auto Answer

When the Auto answer option is activated, your phone automatically answers calls after a specified number of seconds. This option is useful when driving or you are unable to answer the phone.

If Auto Answer is set to 'Off', the phone does not answer the incoming call. If you do not answer the call it is automatically stored in the Missed Call log.

How to enable Auto answer:







1. Press  to display the menu.
2. Press  for Setup.
3. Press  for Auto Answer. The Auto Answer screen displays.
4. Press  to scroll between Off, after 1 second, after 3 seconds, and after 5 seconds. Press  to save your option.
5. Pressing  returns you to the previous screen.

## Answer Mode

When the Answer mode option is activated, your phone allows you to select a specific answer mode when receiving an incoming call. Your phone can be preset to answer when you do any of the following:

- ◆ **Only by send key:** You can answer the phone by pressing .
- ◆ **by flip open:** You can answer the phone by opening the phone's flip.
- ◆ **by any key:** You can answer the phone by pressing any key on the phone.

To set the Answer mode:





1. Press  to display the menu.
2. Press  for Setup.
3. Press  for Answer Mode.
4. Press  to scroll between 'by flip open', 'only by SEND key', 'by any key'. Press  to save.
5. Pressing  returns you to the previous screen.

## Tone Length

Some older phones only recognize longer tones. Therefore you may have to change the tone length for some calls. When calling a paging system, remember that your phone should be set in the normal mode.

To change the Tone length:





1. Press  to display the menu.

2. Press  for Setup.
3. Press  for Tone length. The Tone length screen displays.
4. Press  to scroll between 'Normal', and 'Long'. Press  to save.
5. Pressing  returns you to the previous screen.

## Network

Your Samsung phone allows you to set the network option.

To select the System:

1. Press  to display the menu.
2. Press  for Setup.
3. Press  for Network Option. The Network Option screen is displayed.
4. Scroll between 'Automatic & TELUS Digital'.
5. When the desired option is displayed, press  to save.
6. Press  to exit without saving.





## Data/Fax

Your Samsung phone is capable of sending and receiving digital data and fax calls when connected to a computing device (laptop, desktop, hand held, palmtop, etc.) running Windows 95, Windows 98, Windows 2000, Windows ME, or Windows NT. Your Samsung phone functions similar to a typical modem on your PC, enabling you to use wireless data with a variety of Windows software applications.

To use digital data or fax services with your Samsung phone, you will need to obtain a digital data/fax cable kit from your service provider. This kit contains the necessary cables, software, and documentation required for you to connect and use your Samsung phone with your computing device.





**Note:** The phone must be on a digital network to receive or send faxes and data. When you are in a digital network, the **D** icon is displayed.

To setup Data/Fax:

1. Press  to display the menu.
2. Press  for Setup.
3. Press  for Data/Fax. The Data Mode screen displays.
4. Use the scroll keys to toggle between:
  - ◆ **Data/Fax Off:** (No incoming Data/Fax calls can be received.)
  - ◆ **Fax for Next Call:** (Waiting for Fax Call. No Voice Calls can be received for next 10 minutes.)
  - ◆ **Fax until Powered Off:** (No Voice Calls can be received.)
  - ◆ **Data for Next Call:** (Waiting for data call. No voice calls can be received.)
  - ◆ **Data until Powered Off:** (No voice calls can be received.)
5. When the desired option is displayed, press  to save.
6. Press  to exit without saving.

## Receiving a fax

To receive a fax:





1. Ensure that your phone is connected to your PC and is powered on.
2. Press  to display the menu.
3. Press  for Setup.
4. Press  for Data / Fax.
5. Scroll and select “Fax for Next Call”.
6. Press  to save. The screen displays “Waiting for Fax call.”

**Note:** No incoming Voice Calls can be received for 10 minutes.” Your phone then returns to the standby

7. In the Fax program on your PC, setup the Answer mode. Click on “Receive” and select one of the following:
  - ◆ Automatic Receive (recommended)
  - ◆ Manual Receive

**Note:** Once you have set your phone’s mode to “Fax for Next Call”, you cannot receive regular voice calls until you change back to “Data/fax Off” or a fax has been received.

## Changing your phone back to voice calling

1. Press  to display the menu.
2. Press  for Setup.
3. Press  for Data/Fax.
4. Scroll and select “Data/Fax Off”.
5. Press  to save. The screen displays “No incoming Data/Fax calls can be received”.

## Ending a fax or data call

The usual way of ending a call, like closing the phone, do not end a fax or data call. The connection must be closed through the application on your computer.

**Note:** Disconnecting the data cable or turning off your phone will also end a data or fax call, but may disrupt your computer.

## Sending a fax or data file

When connected to a computing device, your phone allows wireless fax and data transmissions. Your computing device software initiates the call to the destination phone number. Your Samsung phone functions as a wireless modem to send the fax or data file to the number designated by your PC software.

# Mail Kit

**Note:** Check with Service Provider for available services.

The Mail Kit allows you to create, send, read, and save your messages. Your phone receives four kinds of messages: voicemail, text, numeric pages, and browser messages. To access the Mail kit, press  or



The Mail kit contains the following menus:

- ◆ New Messages
- ◆ Inbox
- ◆ Outbox
- ◆ Delivery
- ◆ MSG Setup

## Mobile Originating (MO) SMS Text Messaging

**Note:** Check with Service Provider for available services.



Your phone supports Mobile Originating (MO) SMS Text Messaging. The T-300 is able to send messages containing up to 180 characters, and receive text messages up to 255 characters. When a message is received, the phone sounds an alert tone and a new message pop up window is displayed on the screen.

Messages being sent can contain a total of 160 characters in the message body.

**Note:** A total of 94 messages or 16KB of memory is available for messages. This memory is shared between all messages. The number of messages stored depends on the length of the messages.

### Creating a New SMS Message

To create a new message:

1. Press  to display the Mail Kit menu.
2. Press  for New Message.
3. Enter the email address or phone number of the recipient. Press  to display the following entry options:

◆ Phonebook

◆ T9 Word

◆ ABC

◆ Symbol



◆ 123

◆ .com

◆ .net

◆ Exit



**Note:** Multiple addresses can be entered into the “Message To” screen by separating the address entries with a space. For example; “jdoe@samsung.com” “johnd@samsung.com”. For more information, see “Multiple Addressing” on page 133.

4. Press  to “Accept” and continue.
5. The “Message” screen is displayed.
6. Press  to select the desired mode of character entry. They are:
  - ◆ Word
  - ◆ ABC
  - ◆ Symbol

◆ 123

◆ Exit

◆ Canned



7. Press  to return to the message body.
8. Key in the message using the key pad. A counter in the top right corner of the display screen indicates the remaining characters available.
9. Press  to “Accept” the message.
10. The following choices are available:
  - ◆ Send - Send the message
  - ◆ OK - Save the Message
  - ◆ CLR - Returns to the Edit Menu
  - ◆ END - Discard the message and quit.
11. Press  .

**Note:** Your phone can receive messages in both Standby and InUse modes. When you are on a call and a message is received, your phone automatically mutes the ringer and provides the call waiting tone.

## Multiple Addressing

Multiple addressing allows you to send mobile SMS messages to multiple email or phone numbers by entering them in the “Message To” screen when creating a new SMS message.

To enter multiple addresses:

1. Press  to display the Mail Kit menu.
2. Press  for New Message.
3. Enter the email address or phone number of the recipient.
4. Press  and enter the second email or phone number. Follow this procedure until all the desired addresses are entered.

**Note:** Remember there is a total of 180 characters per message allowed including the email address characters. The more characters used in the email addresses, the less allowed in the actual message.



## Options Menu





The options menu consist of the following delivery options:

- ◆ Message Priority - This setting sets the message priority with the following choices:
  - Normal
  - Urgent
- ◆ Validity Period - This setting determines how long the message is valid for the intended user to read. The available choices are:

- Always
  - 30 min.
  - 1 hour
  - 2 hours
  - 12 hours
  - 1 day
  - 2 days
  - 3 days
- ◆ **Deferred Delivery** - This setting allows you to delay the delivery of the outgoing message. The available choices are:
- Now
  - 30 min.
  - 1 hour
  - 2 hours
  - 12 hours
  - 1 day
  - 2 days
  - 3 days
- ◆ **Delivery Acknowledge** - This setting allows you to request a delivery acknowledgement that the message was received by the user.
- ◆ **Save “Sent” Message** - This setting allows you to save a copy of the outgoing message in the Outbox.
- ◆ **Confirm** - This confirms and saves the settings that have been changed.
- ◆ **Revert** - This automatically reverts the settings back to the original default settings.



## Replying to a Message

1. View the new message.
2. Press  to display the options.
3. Press  to “Reply”.





4. Press  to open the message body.
5. Enter the message using the keypad. Press  when finished.
6. Use  to highlight the Action menu. Press .
7. Press .

## Viewing Messages

To view a message:

1. Press  to display the Mail Kit menu.
2. Press  for Inbox.
3. Press  for Text.

## New Messages

1. Press  for the menu.
2. Press  for Mail Kit.
3. Press  for New Messages.
4. The “Message To” screen is displayed.
5. Press  for the Mode menu. Select the desired entry mode from the following options:
  - ◆ Phonebook
  - ◆ T9 Word
  - ◆ ABC

◆ Symbol

◆ 123

◆ .com



◆ .net

◆ Exit

**Note:** If you choose the “Phonebook” option, follow the prompts to return to the “Message To” screen.

6. When you have entered the recipient information in the “Message To” screen, press  to continue. The “New Message” main screen is displayed.
7. Enter the desired message in the space provided. The number displayed in the upper right corner displays the amount of characters remaining that can be entered.

**Note:** If you receive a call while composing a new message, a pop up window is displayed. Select SEND to answer the incoming call. To save the message being entered, press CLR (As long as a call is NOT disconnected while saving the created message.)

8. When finished, press  to return to the “New Message” main screen.
9. Press the  button down and highlight the “Action” field.
10. Press  to display the “Message Action” menu. The following choices are available:
  - ◆ **SEND** - Send the message to the recipient.
  - ◆ **OK** - Save the message so you can send it later.

◆ **CLR** - Returns you back to the “New Message” main screen.

◆ **END** - Discards the message and exits the MO-SMS system.

11. Press **SEND** to send the message. (Animation is displayed showing that the message has been sent.)

## Inbox

Your phone receives incoming messages in both standby and send modes. When you are on a call and a message is received, your phone automatically mutes the ringer and provides the call waiting tone (this is to avoid ringing in your ear while you are trying to speak).

### Receiving a message in standby mode

When your phone receives a message in standby mode, the ringer sounds (unless turned off), and the screen displays (“New Voicemail”, “New Text”, “New Page” or “New BrowserMsg”). The message indicator is displayed and remains on the screen until you listen to the new voicemail message, read the new Browser message, text message or numeric page.

### Receiving a message while on a call



If you receive a new text message or numeric page while on a voice call, the Call Waiting tone sounds and a pop-up message is displayed. You can easily review the new message while on the call by just pressing **SEND**. Your call is not disconnected and the caller is placed on hold while you review the text message. Press **SEND** again to return to the original call.

### Receiving a Message in Standby Mode





When a message is received in Standby mode, the ringer sounds and an alert message is displayed on the screen to identify the type of

message. The message indicator remains on the screen until you listen or read the new message.

## Reviewing numeric pages, text messages, and browser messages

When a message arrives, you can review it by pressing , or the message can be stored by pressing . The Messages menu provides options for reviewing the sender's name, phone number, time / date stamp and the message.

To review a stored (or old) numeric page, text message, or browser message from the standby mode:

1. Press  to display the Mail Kit menu. The number of new (unread) messages displays next to the associated message type in the menu.
2. Press  for Inbox. A list of messages displays. An exclamation point next to an entry indicates an urgent message. A check mark next to an entry indicates that the message has already been read.
3. Scroll through the list of messages.
4. When a message is displayed, press  to review. While reviewing the message, the scroll keys operate:
  - ◆ By pressing up or down to scroll.
5. Press  to return to the previous screen.



**Note:** While reviewing a message, you can press  for more options. Available options are Call Back, Forward, Save Addr, Erase, Detail, Reply, and Save cb #. The same menu options are available in the Outbox.

## Outbox

The outbox keeps a copy of messages that were sent or saved on the phone.



## Sent

The Sent box keeps a record of the messages that have been sent from the phone. To access the Sent menu:

1. Press  to open the Mail Kit.
2. Press  for Outbox.
3. Press  for Sent.

## Stored



The Stored box keeps a record of the messages that have been saved or not finished prior to sending a new message. To access the Stored menu:

1. Press  to open the Mail Kit.
2. Press  for Outbox.
3. Press  for Stored.



## Message options

When reviewing text messages, the Messages menu provides a number of options. You can return a call to the phone number in the message, save or erase the message, scroll to the next or previous message, or extract a phone number that is included in the message.

1. While reviewing a message, press  (to call the phone number).

2. While reviewing a message, press  for Options:
3. Scroll through the menu with the  key. Press  to select the option.

The following options are available:

- ◆ Call Back. - Automatically calls the number found in the message.
  - ◆ Forward - Automatically forwards the message to another recipient.
  - ◆ Save addr - Automatically saves the entry in you phone book.
  - ◆ Erase - Deletes the message.
  - ◆ Detail - Give the date and time the message was sent and received. Also displays the encoding information.
  - ◆ Reply - Automatically generate a reply message.
  - ◆ Save cb# - Saves the call back number in the phone book.
4. Highlight “Save addr” and press  to extract the number included by the sender of the message. If more than one number was included by the sender, then a list of the numbers is available. Select the one you want.
  5. Press  to return to the previous screen.

## Message Ringing









Your phone allows you to set unique ring types. (see “Ringer Type” on page 91).

## Message Time

You can select one of three time stamps to be used for your incoming messages. The time stamps to choose from are:

- ◆ UTC (Universal Time Coordinated). This stamps messages with the time setting from the message center. The time stamp is based on Greenwich Mean Time.
- ◆ Local Time. This stamps messages with the local time based on your coverage area.
- ◆ Time Received: This setting causes your messages to be stamped with the time that your phone received the message in your home time zone. This setting may not work in some analog coverage areas.

## Creating a New Message:

1. Press  to open the Mail Kit.
2. Press  for New Messages
3. Press the  and scroll through Phone #, E-mail, or Phonebook.
4. Press  to select the option.
5. Press  to enter a message.
6. Press  and toggle through T9 Word, ABC, Symbol, 123, Exit, or Canned.
7. Press  to select the option.
8. Enter the text message and press  to accept.
9. The following options are displayed:
  - ◆ **SEND:** Send Message
  - ◆ **OK:** Save Message
  - ◆ **CLR:** Back to Edit

◆ **END:** Discard and quit.

10. Choose the desired option and press the corresponding key.

## Message Memory Capacity

Your phone can store up to 16 kbytes or 94 messages. This storage capacity includes all message types; numeric page, VMN (voicemail notification), text, and browser. The number of messages stored depends on the length of the messages. When message memory reaches 75% capacity, the screen displays “Memory is 75% full. Erase old messages.” At 100% capacity, the screen displays a text notification and rejects additional incoming messages until you erase the stored messages. The measurement is determined by either the amount of messages, or the size allocated for the messages in memory. Whatever amount is greater is measured as a percentage.

## Messages and Lock Mode

Incoming messages are received even when your phone is in Lock Mode. The screen displays the time and date of the message, but you cannot access the message. To access the message, you must unlock the phone.

## Voicemail



Voicemail is available on your phone provided that you are signed up for the service through the carrier. When you have a new voicemail message, a sound plays and the LED on the phone flashes to indicate a message is available. The screen also displays a message that says “Voice Messages Received”.

**Note:** Different ringer types can be set to notify you that a new voicemail has been received. To set options, see “Ringer Type” on page 91

## Listening to your Messages

To listen to new messages:



**Note:** Applicable charges apply when checking your voicemail. This is considered an outgoing call.

1. Press  to display the Mail Kit menu.
2. Press  for Inbox.
3. Press  for new Voicemail.

**Note:** You can also press and hold  to dial your voicemail.

# Security

## Security Features

Your phone provides security options, including a user-programmable lock code and special phone number features. To access the Security menu in standby mode, press , , and enter the 4-digit lock code. (normally the lock code is the last 4-digits of your phone number). Press the associated numeric key to access one of the following Security options:

- ◆ Lock Mode
- ◆ Restrict
- ◆ Lock code
- ◆ Emergency #
- ◆ Send PIN
- ◆ Clear MEM
- ◆ Reset Phone



## Lock Mode



Locking the phone limits all outgoing calls except calls to hard-coded emergency numbers (911, \*911 and #911).

You can lock the phone manually during use, or set the phone to lock automatically when it is turned on. When the phone is in Lock Mode, you can answer incoming calls, but you must unlock the phone to place outgoing calls.

## Locking the phone

To lock the phone:

1. Press  to display the menu.
2. Press  for Security and enter your lock code.

3. Press  for Lock Phone.
4. Scroll through the options:
  - ◆ **Never:** The phone remains unlocked.
  - ◆ **Now:** The phone locks immediately and stays locked until the lock code is entered.
  - ◆ **Power On:** The phone locks automatically the next time your phone is powered on and stays locked until the lock code is entered.
  - ◆ Press  to save the setting.

## Unlocking the phone

When the phone is locked, it displays a “Locked” screen. To unlock the phone, press . Enter the phone’s lock code, and the phone is immediately unlocked.

## Dialing in lock mode

You can place calls to emergency and special numbers in the lock mode. To place normal outgoing calls in lock mode, enter the lock code to unlock the phone, and then dial the phone number.







## To place an outgoing call in lock mode:

1. To call an emergency or special number, enter the number and then press .

## Restrict

This feature allows you to restrict the use of your phone.



To restrict the phone:

1. Press  to display the menu.
2. Press  for Security.
3. Enter your current lock code.
4. Press  for Restrict.
5. Press  to scroll between 'Yes' or 'No'. Press  to confirm the restriction.
6. Press  to exit.

## Lock Code

The default lock code for your phone is the last four digits of your phone number. You can enter a personal lock code or change the lock code as often as you like.

To enter a new lock code:

1. Press  to display the menu.
2. Press  for Security.
3. Enter your current lock code.
4. Press  for Lock Code.
5. Enter a new 4-digit lock code by pressing the numeric keys.

6. Press  to save the new lock code.

7. Press  to exit.

**Note:** Your phone does not allow viewing of the lock code unless you know the lock code (this is for obvious security reasons). So, if you change the lock code, be sure to write down or memorize the new code.

## Emergency #

Your phone provides the option of storing three emergency or special numbers. Each special number can be ten digits long.

All special numbers can be manually dialed at any time, even when your phone is locked. This feature is useful for controlling what numbers can be dialed from your phone.

**Note:** Even if your account is restricted, you can still dial 911, but no other emergency numbers.

## **Important:** IMPORTANT NOTICE! PLEASE READ!

Because of various transmission methods, network parameters, and user settings used to complete a call from your wireless phone, a connection cannot always be guaranteed.







Therefore, emergency calling may not be available on all wireless networks at all times.

DO NOT depend on this phone as a primary method of dialing 911 or for any other essential or emergency communications.

Remember to always turn your phone on and check for adequate signal strength before placing a call.



## Storing numbers



To store special numbers:

1. Press  to display the menu.
2. Press  for Security and enter your current lock code.
3. Press  for Emergency #.
4. Press  to the left and the screen will display the Emergency #: either 1, 2, or 3 on the screen.
5. Enter the special number.
6. If you scroll to the right with the  key, the phone permits you to enter the next emergency screen.
7. Scrolling left allows you to edit the number just entered.
8. Pressing  allows you to save the number entered.
9. Press  to return to the Security menu.

## Send PIN

**Note:** The PIN (Personal Identification Number) feature prevents your phone from being used by unauthorized persons. Contact your service provider for complete information on this feature. To set your phone to prompt for your PIN to be sent to the system whenever a call is placed.





1. Press  to display the menu.
2. Press  for Security and enter your current lock code.

3. Press  for Send Pin.
4. Choose between Never or Prompt.
5. Press  to save the choice.

## Clearing the Memory

You can erase all the numbers stored in your Phone Book and voice dial recordings. This is useful if you want to give your phone to a friend or family member, or if you want to erase all of your phone numbers.

To erase your phone book:





1. Press  to display the menu.
2. Press  for Security and enter your current lock code.
3. Press  for Clear MEM. A confirmation message displays asking if you want to 'Clear All?'
4. Press  to erase the Phone Book.
5. Press  to "Cancel" the operation.

"Erasing" displays while the operation is completed. The phone then returns to standby mode.

## Resetting the Phone

The Reset option resets the phone and returns all options to the factory default settings. All your Personal settings (Phone Book, Voice Dial recordings, Messages, and Calendar) are not affected by resetting your phone.

To reset the phone:

1. Press  to display the menu.
2. Press  for Security and enter your current lock code.
3. Press  for Reset Phone. A confirmation displays explaining that you will reset the phone to factory defaults.
4. Press  to reset the phone
5. Press  to cancel the operation.
6. The phone resets and restores the default settings, erases your messages and then returns to standby mode.

# InUse Menu

Your phone includes both a menu and an InUse menu. The InUse menu is displayed by pressing the  button while the phone is being used.

The InUse menu options are:

1. **Mute/Quit** - Mutes the microphone so that the caller cannot hear your conversation. You can still hear the caller, they just cannot hear you.
2. **Calls** - Checks your call log for outgoing, incoming, and missed calls. You can also erase the logs from this menu.
3. **PhoneBook** - Accesses the PhoneBook menu options.
4. **Silent/Quit** - This option silences the key beep tones when numbers are pressed on the handset. Access the option again to turn off the silence.
5. **Send Tel #** - Send the telephone number of the phone to the other caller.
6. **My Phone #** - Displays the phone number of the phone being used.
7. **Version** - Displays the version of the software and hardware that is being used on the phone.

# Usage guidelines: all about performance and safety

## Understanding Signal Strength

The quality of each call you make or receive, is dependent upon the signal strength in your area. Your phone informs you of the current signal strength by displaying a icon. The more bars displayed, the stronger the signal. The signal strength indicator (  ) displays in the upper left corner of your display screen. The voice quality of your phone is always clearest when the antenna is fully raised. If you're inside a building, reception may be better near a window.

## Understanding the Power Save Mode

If you are trying to use your phone in an area where the signal is too weak, the Power Save feature automatically activates to conserve battery power when you have been unable to pick up a signal for 15 minutes. If your phone is on, it periodically rechecks service availability. To manually check, press any key. A message is displayed on the screen any time Power Save has been activated. When a signal is found, your phone returns to standby mode.

## Understanding how Your Phone Operates

Your phone is basically a radio transmitter and receiver. When it is turned on, it receives and transmits radio frequency (RF) signals. When your phone is in use, the system handling your call controls the power level. This power can range from 0.006 watts to 0.2 watts in digital mode.

## Specifications are Subject to Change

The information contained in this manual is believed to be correct at the time of printing, however, Samsung reserves the right to change

or modify any of the specifications without notice or obligation to update existing units.

## **Exposure To Radio Frequency Signals**

Your wireless handheld portable telephone is a low power radio transmitter and receiver. When it is ON, it receives and also transmits radio frequency (RF) signals

In August, 1996, the Federal Communications Commission (FCC) adopted RF exposer guidelines with safety levels for hand-held wireless phones. Those guidelines are consistent with the safety standards previously set by both U.S. and international standards bodies:

- ◆ ANSI C95.1 (1992)
- ◆ NCRP Report 86 (1986)
- ◆ ICNIRP (1996)

Those standards were based on comprehensive and periodic evaluations of the relevant scientific literature. For example, over 120 scientists, engineers, and physicians from universities, government health agencies, and industry reviewed the available body of research to develop the ANSI standard (C95.1).

The design of your phone complies with the FCC guidelines (and those standards).

## **Antenna Care**

Use only the supplied or an approved replacement antenna. Unauthorized antennas, modifications, or attachments could damage the phone.

## Phone Operation

**NORMAL POSITION:** Hold the phone as you would any other telephone with the antenna pointed up and over your shoulder.

### Tips on Efficient Operation

For your phone to operate most efficiently:

- ◆ Extend your antenna fully.
- ◆ Do not touch the antenna unnecessarily when the phone is in use. Contact with the antenna affects call quality and may cause the phone to operate at a higher power level than otherwise needed.

## Operating a Motor Vehicle

Check the laws and regulations on the use of wireless telephones in the areas where you drive. Always obey them. Also, if using your phone while driving, please:

- ◆ Give full attention to driving - driving safely is your first responsibility.
- ◆ Use hands free operation, if available.

## Electronic Devices

Most modern electronic equipment is shielded from RF signals. However, certain electronic equipment may not be shielded against the RF signals from your wireless phone.

### Pacemakers

The Health Industry Manufacturers Association recommends that a minimum separation of six (6") inches be maintained between a handheld wireless phone and a pacemaker to avoid potential interference with the pacemaker. These recommendations are consistent with the independent research by and recommendations of Wireless Technology Research.

Persons with pacemakers:

- ◆ Should ALWAYS keep the phone more than six inches from their pacemaker when the phone is turned ON;
- ◆ Should not carry the phone in a breast pocket;
- ◆ Should use the ear opposite the pacemaker to minimize the potential for interference;
- ◆ If you have any reason to suspect that interference is taking place, turn your phone OFF immediately.

## Other Medical Devices

If you use any other personal medical device, consult the manufacturer of your device to determine if they are adequately shielded from external RF energy. Your physician may be able to assist you in obtaining this information.

Turn your phone Off in health care facilities when any regulations posted in these areas instruct you to do so. Hospitals or health care facilities may be using equipment that could be sensitive to external RF energy.

## Posted Facilities

Turn your phone Off in any facility where posted notices so require.

## Aircraft

Turn off our phone before boarding any aircraft. To prevent possible interference with aircraft systems, the U.S. Federal Aviation Administration (FAA) and Canadian Department of Transportation regulations require you to have permission from a crew member to use our phone while the plane is on the ground. To prevent any risk of interference, these regulations prohibit using your phone while the plane is in the air.

## **Blasting Areas**

To avoid interfering with blasting operations, turn your phone Off when in a “blasting area” or in areas posted: “Turn off two-way radio”. Obey all signs and instructions.

## **Potentially Explosive Atmospheres**

Turn your phone Off when in any area with a potential explosive atmosphere and obey all signs and instructions. Sparks in such areas could cause an explosion or fire resulting in bodily injury or even death.

Areas with a potentially explosive atmosphere are often, but not always clearly marked. They include fueling areas such as gasoline stations; below deck on boats; fuel or chemical transfers or storage facilities; vehicles using liquefied petroleum gas (such as propane or butane); areas where the air contains chemicals or particles, such as grain, dust, or metal powders; any other area where you would normally be advised to turn Off your vehicle engine.

## **For Vehicles Equipped with an Air bag**

An air bag inflates with tremendous force. DO NOT place objects, including both installed or portable wireless equipment, in the area over the air bag or in the air bag deployment area. If in-vehicle wireless equipment is improperly installed and the air bag inflates, serious injury could result.

## **Storing your phone**

You must not store or carry your phone, its parts, or accessories in the same compartment or other area where there flammable liquids, gases, or explosive or flammable materials.

## Cautions

Any changes or modifications to your phone not expressly approved in this document could void your warranty for this equipment and void your authority to operate this equipment.

Only use approved batteries, antennas, and chargers. The use of any unauthorized accessories may be dangerous and will invalidate the phone warranty if said accessories cause damage or a defect to the phone.

Although your phone is quite sturdy, it is a complex piece of hardware and can be broken. Use common-sense guidelines to avoid dropping, hitting, bending, or sitting on it.

## Voice Memo

The voice memo feature of your phone is intended to let you record information when a pencil and paper may not be available. Before using this feature to record any part of a telephone conversation, you should make sure that the recording will not be made or used for any wrongful or unlawful purpose and that you have the consent of other parties to the call if required by law or under your service agreement. Under the laws of some states, for example, recording any part of a telephone call is illegal unless every person on the call consents to your making of the recording. State and federal law may impose serious criminal penalties, in addition to possible civil liability, for unlawful recording of a telephone call or for disclosure of an illegally recorded conversation. Check to be sure that your intended use of this feature will comply with all applicable laws before recording or playing back a telephone conversation.

## Information to User

This equipment has been tested and found to comply with the limits of a Class B digital device, pursuant to Part 15 of the FCC Rules. These limits are designed to provide reasonable protection against harmful interference in a residential installation. This equipment generates, uses and can radiate radio frequency energy and, if not installed and used in accordance with the instructions, may cause harmful interference to radio communications. However, there is no guarantee that interference will not occur in a particular installation; if this equipment does cause harmful interference to radio or television reception, which can be determined by turning the equipment off and on, the user is encouraged to try to correct the interference by one or more of the following measures:

- ◆ 1. Reorient / Relocate the receiving antenna.
- ◆ 2. Increase the separation between the equipment and receiver.
- ◆ 3. Connect the equipment into an outlet on a circuit different from that to which the receiver is connected.
- ◆ 4. Consult the dealer or an experienced radio/TV technician for help.

**CAUTION:** Changes or modifications not expressly approved by the manufacturer responsible for compliance could void the user's authority to operate the equipment.

# Your Phone as a Network Device

Your telephone requires a service provider to send and receive calls. Your phone is only one part of a system or “network” of devices that makes it possible for you to send and receive calls, text messages, voice message, access the Internet using the minibrowser, and to take advantage of all of the other services and features available when your phone is used with your service provider.

Your phone will always try your call using your home system, but if this is unavailable, then the phone will use the preferred network system.

If you cannot network, your call will not be connected and the **R** icon is displayed. In some service areas, an operator may come on the line asking you how you would like to pay for the call.

To make all of the features available to you, your phone is designed by Samsung and your service provider to allow your service provider to send (at any time) a variety of information and messages to your phone. You may think of this as an over the air service to your phone. During an over-the-air programming session, your phone may display the following messages:

- ◆ “Search... Download” - this message means the phone is looking for the data to download.
- ◆ “Progress Download” - this message means the phone is downloading data. *Do not turn your phone off while this is occurring.* See the **CAUTION** below.
- ◆ “Download Success” - this message means that your phone has been successfully reprogrammed. You can now continue to use your phone as you normally do.
- ◆ “Download Failed” - if this message appears contact your service provider.

**CAUTION:** If you turn off your phone during a download, your phone (or some features) may not work properly in the network. If this happens don't worry, contact your service provider for help in correcting the problem.

## **Acknowledging Special Precautions and the FCC and Industry Canada Notice**

### **Cautions**

Any changes or modifications to your phone not expressly approved in this document could void your warranty for this equipment and void your authority to operate this equipment.

Only use approved batteries, antennas, and chargers. The use of any unauthorized accessories may be dangerous and will invalidate the phone warranty if said accessories cause damage or a defect to the phone. Although your phone is quite sturdy, it is a complex piece of hardware and can be broken. Use common-sense guidelines to avoid dropping, hitting, bending or sitting on it.

### **FCC and Industry Canada Notice**

This device may cause TV or radio interference if used in close proximity to receiving equipment. The FCC and Industry Canada can require you to stop using the telephone if such interference cannot be eliminated. If you need assistance, contact our service provider.

### **Information to User**

This equipment has been tested and found to comply with the limits of a Class B digital device, pursuant to Part 15 of the FCC Rules. These

limits are designed to provide reasonable protection against harmful interference in a residential installation. This equipment generates, uses and can radiate radio frequency energy and, if not installed and used in accordance with the instructions, may cause harmful interference to radio communications. However, there is no guarantee that interference will not occur in a particular installation; if this equipment does cause harmful interference to radio or television reception, which can be determined by turning the equipment off and on, the user is encouraged to try to correct the interference by one or more of the following measures:

- ◆ Reorient / relocate the receiving antenna.
- ◆ Increase the separation between the equipment and receiver.
- ◆ Connect the equipment into an outlet on a circuit different from that to which the receiver is connected.
- ◆ Consult the dealer or an experienced radio/TV technician for help.

## **Samsung Phone and Battery Specifications**

Tri Mode:	CDMA 1.9GHz / CDMA 800MHz/ AMPS 800 MHz
Display Screen:	Graphical LCD (with 1 dedicated Icon Line)
Battery Type:	Standard: Lithium-Ion
PCS Antenna:	Retractable, user-replaceable

## **Samsung Phone with Standard Battery**

Talk Time Digital:	200 Minutes
Analog:	90 Minutes
Standby Time Digital:	120 Hours
Analog:	15 hours

## Samsung T-300 Phone with Extended Battery

Talk Time Digital:	300 Minutes
Analog:	135 Minutes
Standby Time Digital:	180 Hours
Analog:	22 Hours

### Owner's Record

The model number, regulatory number and serial number are located on a nameplate inside the battery compartment. Record the serial number in the space provided below. This will be helpful if you need to contact us about your phone in the future.

Model:

Serial No.:

### User Guide Proprietary Notice

CDMA Technology is licensed by QUALCOMM Incorporated under one or more of the following Patents:

4,901,307, 5,109,390, 5,267,262, 5,416,797

5,506,865, 5,544,196, 5,657,420, 5,101,501

5,267,261, 5,414,796, 5,504,773, 5,535,239

5,600,754, 5,778,338, 5,228,054, 5,337,338

5,710,784, 5,056,109, 5,568,483, 5,659,569

5,490,165, 5,511,073

T9® Text Input is licensed by Tegic Communications and is covered by U.S. Pat. 5,818,437, U.S. Pat. 5,953,541, U.S. Pat. 6,011,554 and other patents pending.

Licensed by Qualcomm Incorporated under one or more of the following patents: U.S. Patent No. 4,901,307; 5,056,109; 5,099,204; 5,101,501; 5,103,459; 5,107,225; 5,109,390.

Openwave® is a registered Trademark of Openwave, Inc.

## Limited Warranty

### 1. What is covered and for how long?

Samsung Telecommunications America, Inc. (Samsung) warrants the original purchaser that Samsung's phones and accessories are free from defects in material and workmanship under normal use and service for a period commencing on the date of purchase and continuing for the specified period of time after the date:

- ◆ Samsung Phone - 1 year
- ◆ Batteries - 1 year
- ◆ Leather Cases - Defect-free at time of purchase.
- ◆ Other Phone Accessories - 1 year

### 2. What is not covered?

The limited warranty is conditioned upon proper use of the product by the purchaser. This limited warranty does not cover:

- ◆ Defects or damage resulting from accident, misuse, abuse, neglect, unusual physical, electrical, or electromechanical stress, modifications of any part of the product, including antenna or cosmetic damage.
- ◆ Equipment that has the serial number removed or made illegible.
- ◆ All plastic surfaces and other externally exposed parts that are scratched or damaged due to normal usage.
- ◆ Malfunctions resulting from the use of the product in conjunction with the accessories, products, ancillary, or peripheral equipment not furnished or approved by Samsung.

- ◆ Defects or damage from improper testing, operation, maintenance, installation, adjustment and service of products.
- ◆ The limited warranty covers batteries only if the battery falls below 80% of rated capacity or the battery leaks and this limited warranty does not cover any battery if (i) the battery has been charged by a battery charger not specified or approved by Samsung for charging the battery, (ii) any of the seals on the battery are broken or show evidence of tampering, or (iii) the battery has been used in equipment other than the Samsung phone for which it is specified.

### 3. What are Samsung's Obligations?

During the applicable warranty period, Samsung will repair or replace at Samsung's sole option, without charge to purchaser, any defective component part of the phone or accessory. To obtain service under this limited warranty, purchaser must return the product to an authorized Samsung phone service facility in an adequate container for shipping, accompanied by the purchaser's sales receipt or comparable proof of sale showing the date of purchase, the serial number of the product, and the seller's name and address. To obtain information on where to deliver the phone or accessory, call your service provider or Samsung Customer Care at (888) 987-4357. Upon receipt, Samsung will promptly repair the defective product. Samsung may, at Samsung's sole option, use rebuilt, reconditioned, or new parts or components when repairing any product or replace a product with a rebuilt, reconditioned, or new product. Repaired products will be warranted for a period equal to the remainder of the original limited warranty on the original product or for 90 days, whatever is longer. All replaced parts, components, boards, and equipment becomes the property of Samsung. If Samsung determines that any product is not covered by this limited warranty, purchaser must pay all parts, shipping, and labor charges for the repair or return of said product.

4. What are the limits of Samsung's liability?

The warranties given in this limited warranty are in lieu of all other warranties, expressed or implied, including, but not limited to, any warranties of merchantability or fitness for a particular purpose, and are limited to the duration of this limited warranty. Except to the extent prohibited by applicable law. Samsung shall not be liable for any special, incidental, consequential, indirect or similar damages, loss of profits, damages to purchaser's property or injury to purchaser or other parties arising out of the use, misuse, or inability to use any Samsung phone or accessory, breach of warranty, breach of contract, or negligence, including but not limited to Samsung's phones and accessories. This limited warranty shall not extend to anyone other than the original purchaser of this product and states the purchaser's exclusive remedy. If any portion of this warranty is illegal or unenforceable by reason of law, such partial illegality or unenforceability shall not affect the enforceability of the remainder of this limited warranty which purchaser acknowledges is and will always be construed to be limited by its terms or as limited as the law permits. This limited warranty allocates risk of product failure between purchaser and Samsung, and Samsung's products pricing reflects this allocation of risk and the limitations of liability contained in this limited warranty. The agents, employees, distributors, and dealers of Samsung are not authorized to make modifications to this limited warranty, or make additional warranties binding on Samsung. Accordingly, additional statements such as dealer advertising or presentations, whether oral or written, do not constitute warranties by Samsung and should not be relied upon.

5. How does state or territorial law apply to this warranty?

Some states or provinces do not allow the exclusion or limitations of incidental or consequential damages or how long implied warranty lasts, so the above limitations or exclusions may not apply to you.

This warranty gives you specific legal rights. You may also have other rights which vary from one jurisdiction to another.

**Samsung Telecommunications America, Inc.**

**1130 East Arapahoe Road**

**Richardson, Texas 75081**

**(888) 987-HELP (4357)**

# Index

## Numerics

0 / next key, 74

## A

Accessing menus by scrolling, 33

Accessing menus using short cut number, 34

Adding a name ringer, 63

Adjusting ringer volume, 90

Air time, 49

Alarm, 89

Alarm set, 89

Alerts, 94

Animation, 103

Answer mode, 125

Answering a call, 54

Antenna, 21

Assigning a Specific Memory Address, 57

Asterisk / shift key, 74

Auto answer, 124

Auto retry, 123

## B

Backlight features, 21

Browser MSG, 94

## C

Calculator, 87

Calendar, 82

Call Answer, 115

Call Screen, 116

Calls - Incoming, 44

Calls - Missed, 45

Calls - Outgoing, 44

Caring for the battery, 43  
Charging with the travel charger, 41  
Clearing the Memory, 149  
CLR (Clear) key, 21  
CLR key, 74  
Connect, 96  
Conversation/Talk Mode, 36  
Countdown, 85

## D

Data/fax, 126  
Dialing in Lock Mode, 145  
Dialing numbers from the phone book, 68  
Disconnect, 96  
Display options, 101  
Display screen, 21  
Disposal of Lithium Ion batteries, 43

## E

Editing phone book numbers, 60  
E-mail address, 63  
empty battery icon, 41  
End (power on/off key), 22  
END key, 74  
Ending a fax or data call, 129  
Entering text, numbers, or symbols, 75  
Erase logs, 47  
Erase total, 51  
Erasing the phone book, 62

## F

Fade, 97  
Find name, 55  
Finding an Entry, 64  
Front flip, 22

Front view of the Samsung T300, 20

## G

Games, 119

Games - Push Push, 119

Games - Setup, 119

Getting to know your phone, 21

Greeting (Default), 116

## H

Headset connector, 22

## I

Installing the battery, 39

Interface, 24

Interface Adapter, 24

## K

Key beep, 94

## L

Last call, 49

LCD Contrast, 107

LED indicator, 23

Lifetime, 52

List of menu functions, 28

Lock Code Setting, 146

Lock Mode, 144

Lock mode, 35

Locking the Phone, 145

## M

Mail Kit, 130

Mail kit - Erasing individual messages, 142

Mail kit - Inbox, 137

Mail kit - Message memory capacity, 142

Mail kit - Message ringing, 140

Mail kit - Message time, 140

Mail kit - Messages and lock mode, 142  
Manual pause dialing, 60  
MENU key, 75  
Menu key, 23  
Message Options, 139  
Message Ringing, 140  
Microphone, 23  
Minibrowser - exiting, 71  
Minibrowser - launching, 70  
Multiple Addressing, 133

## N

Navigation key, 74  
Network Option, 126  
Number entry, 76  
Numbered keys 0, 74  
Numbered keys 0 - 9, 74  
Numeric key functions, 23

## O

OK/Navigation key, 23  
Outbox, 139

## P

Pause dialing, 58  
Phone Book, 53  
phone modes, 35  
Pound / space key, 74  
Power save mode, 35  
Prepending a phone number, 61  
Protecting your battery, 43

## R

Receiver, 23  
Receiving a fax, 128  
Relation search, 65

- Removing the battery, 40
- Resetting the Phone, 150
- Returning to the previous menu, 34
- Reviewing Airtime, 49
- Ringer options, 90
- Ringer type, 91
- Roam Ringer, 99
- S**
- Scheduler, 79
- Scheduler - How to schedule an event, 81
- Scheduler - How to view an event, 81
- Secret phone book numbers, 65
- Security, 144
- Security - Dialing in lock mode, 145
- Security - Emergency, 147
- Security - Lock code, 146
- Security - Lock mode, 144
- Security - Locking the phone, 145
- Security - Restrict, 146
- Security - Unlocking the phone, 145
- Send key, 23
- Send PIN, 148
- Sending a fax or data file, 129
- Set NAM, 126
- Set Network, 130
- Set Time, 106
- Setting speed dial, 66
- Software/Hardware Version, 107
- Standby mode, 35
- Storing numbers, 148
- Storing phone numbers at the end of a call, 67
- Symbol entry, 77

## **T**

- Tips on recording names, 108
- Tone length, 125
- Turning your phone off, 27
- Turning your phone on, 26

## **U**

- Usage guidelines, 152
- Using your phone's menus, 33

## **V**

- Voice dial, 108
- Voice dial - Language, 111
- Voice dial - Record, 109
- Voice dial - Set active, 111
- Voice dial - Training, 111
- Voice dial - Undo Train, 112
- Voice mail, 93
- Voice memo, 113
- Voice memo - Reviewing, 114
- Voice memo button, 24
- Voice Memo, Recording, 113
- Voice volume, 98

## **W**

- Web/MiniBrowser, 70
- World Time, 87

## **Y**

- Your consumer package, 19

# Quick Reference Guide

## Features

- ◆ Data Friendly High Resolution LCD
- ◆ Dedicated Web Access Key
- ◆ 2-Way SMS
- ◆ Data Enabled
- ◆ Voice Activated Dialing
- ◆ Scheduler
- ◆ 1/2/3 Touch Dialing
- ◆ Fully Animated Menu Functions
- ◆ Up to 12 lines of Text



<b>To</b>	<b>Then</b>
Power the SCH-T300 On/Off.	Press and hold the “End” key.
Menu Scrolling	Press “Menu” and then press the “OK” key up or down.
Answer a Call	Press the “Send” key.
Redial the last call	Press the “Send” key twice.
Speed Dialing	Press the memory number, then “Send”.
End Call	Press “End”.
Save Numbers	Enter the number and press “OK”. Follow the screen prompts.
Outgoing Calls	Press “Menu”, “1”, “1” to review the last 10 outgoing calls.
Incoming Calls	Press “Menu”, “1”, “2” to review the last 10 incoming calls.
Phone Book Search	Press “OK” Down for a numerical search, or Up for a look up search.
Voicemail	Press “OK” to display the Inbox. Then press “2”, “1”, and “Send” to connect to Voicemail.
One Touch Web Access	Press the Internet button.